

LIBERTY UTILITIES

**Requirements For
Electric Service And Meter Installations**

Commercial & Industrial



**Liberty
Utilities®**

(800) 206 – 2300

The latest revision of this book can be found on-line at:
<https://central.libertyutilities.com/all/commercial/new-service/service-standards.html>
Select "Commercial and Industrial Service Standards 2021".

Effective
02/18/2021

Intentionally left blank

Some of the information in this booklet is based on governmental codes and ordinances as well as the National Electrical Code and the tariffs of Liberty Utilities on file with the Public Service Commissions. These requirements and guidelines are issued with the intent of complying with all applicable codes, ordinances and tariffs; however, in the case of conflict, the appropriate code, ordinance and tariff will supersede the interpretation offered in this booklet. In addition, these requirements are subject to change in the event that the governing codes, ordinances and tariffs are changed. Liberty Utilities does not assume responsibility for keeping this book current and should be consulted in case of doubt on the applicability of any terms.

When the term "contact the Company" is used in this booklet, it shall mean for each and every installation, not a single contact.

This publication includes a number of changes and supersedes all previous editions.

THIS PAGE INTENTIONALLY LEFT BLANK

TABLE OF CONTENTS

INTRODUCTION	1
2.0 GENERAL INFORMATION	2
2.1 DEFINITIONS	2
2.2 AVAILABILITY AND LOCATION OF SERVICE.....	7
2.3 TYPE AND CHARACTER OF SERVICE.....	7
2.4 GENERAL REQUIREMENTS.....	7
2.5 ALTERATIONS AND ADDITIONS	9
3.0 METERING.....	10
3.1 GROUNDING.....	10
3.2 METERING EQUIPMENT LOCATIONS.....	10
4.0 INFORMATION APPLYING TO ALL SERVICES	11
5.0 TEMPORARY SERVICES.....	12
6.0 OVERHEAD SERVICES	18
6.1 GENERAL INFORMATION	18
6.2 100 AMP, 200 AMP, AND 320 AMP SINGLE PHASE OVERHEAD SERVICES	20
6.3 400 AMP TO 800 AMP CT METERING, SINGLE PHASE OVERHEAD SERVICE	35
6.4 MULTIPLE METERS, SINGLE PHASE OVERHEAD SERVICE.....	42
6.5 100/200 AMP(208Y/120V or 240Δ /120V only) THREE PHASE OVERHEAD SERVICE	46
6.6 200 AMP TO 1200 AMP CT METERING, THREE PHASE OVERHEAD SERVICE.....	53
6.7 MULTIPLE METERS, THREE PHASE OVERHEAD SERVICE	60
7.0 UNDERGROUND SERVICES	66
7.1 GENERAL INFORMATION	66
7.2 200 AMP AND 320 AMP SINGLE PHASE UNDERGROUND SERVICE	70
7.3 400 AMP TO 800 AMP CT METERING, SINGLE PHASE UNDERGROUND SERVICE	82
7.4 MULTIPLE METERS, SINGLE PHASE UNDERGROUND SERVICE	86
7.5 200 AMP(208Y/120V or 240Δ/120V only) THREE PHASE UNDERGROUND SERVICE.....	90
7.6 200 AMP TO 1200 AMP CT METERING, THREE PHASE UNDERGROUND SERVICE	96
7.7 MULTIPLE METERS (208Y/120V or 240 DELTA/120V only), THREE PHASE UNDERGROUND SERVICE.....	100
8.0 UNDERGROUND SERVICE FROM 3 PHASE PADMOUNT TRANSFORMER	104
8.1 CT METERING ON THE TRANSFORMER (Preferred Method)	104
8.2 METERING ON THE BUILDING	107
APPENDIX A.....	116
APPENDIX B.....	122

TABLE OF FIGURES

FIGURE 1: DEFINITIONS-----	4
FIGURE 2: DEFINITIONS-----	5
FIGURE 3: DEFINITIONS-----	6
FIGURE 4: TEMPORARY SERVICE FROM OVERHEAD FACILITIES-----	14
FIGURE 5: TEMPORARY SERVICE FROM UNDERGROUND FACILITIES-----	15
FIGURE 6: TEMPORARY SERVICE FROM UNDERGROUND FACILITIES (CONTINUED)-----	16
FIGURE 7:FUTURE-----	17
FIGURE 8: 100/200/320 AMP OVERHEAD SERVICE-----	22
FIGURE 9: 100/200/300 AMP STEEL SERVICE MAST-----	23
FIGURE 10: 100/200 AMP METER SOCKET, OVERHEAD SERVICE-----	24
FIGURE 11: 100/200 AMP METER SOCKET, NETWORK (120/208) OVERHEAD SERVICE-----	25
FIGURE 12: 100/200 AMP COMBINATION METER SOCKET-----	26
FIGURE 13: 100/200 AMP COMBINATION METER SOCKET, NETWORK (120/208) OVERHEAD SERVICE-----	27
FIGURE 14: 320 AMP METER SOCKET, OVERHEAD SERVICE-----	28
FIGURE 14A: 320 AMP METER SOCKET, NETWORK (120/208), OVERHEAD SERVICE-----	29
FIGURE 15: 320 AMP COMBINATION METER SOCKET, OVERHEAD SERVICE-----	30
FIGURE 15A: 320 AMP METER SOCKET, NETWORK (120/208), OVERHEAD SERVICE-----	31
FIGURE 16: 100/200 AMP METER POLE, UNDERGROUND FEEDER-----	32
FIGURE 17: 100/200 AMP METER POLE, OVERHEAD FEEDER-----	33
FIGURE 18: 320 AMP METER POLE, UNDERGROUND FEEDER-----	34
FIGURE 19: 320 AMP METER POLE, OVERHEAD FEEDER-----	35
FIGURE 20: 400 AMP TO 800 AMP CT METERING, OVERHEAD SERVICE-----	38
FIGURE 21: 400 AMP TO 800 AMP CT METERING, WITH SERVICE MAST-----	39
FIGURE 22: 400 AMP TO 800 AMP CT METERING, POLE-----	40
FIGURE 23: 400 AMP TO 800 AMP CT METERING, POLE, UNDERGROUND FEEDER-----	41
FIGURE 24: WIRING OF TWO METERS, OVERHEAD SERVICE-----	44
FIGURE 25: THREE TO SIX METERS, OVERHEAD SERVICE-----	45
FIGURE 26: 100/200 AMP OVERHEAD SERVICE-----	48
FIGURE 27: 100/200 AMP STEEL SERVICE MAST-----	49
FIGURE 28: 100/200 AMP METER SOCKET, OVERHEAD SERVICE-----	50

TABLE OF FIGURES

FIGURE 29: POWER LEG CONNECTION ON 3 PHASE, 4 WIRE DELTA CONNECTED SYSTEMS -----	51
FIGURE 30: 100/200 AMP METER POLE, UNDERGROUND FEEDER -----	52
FIGURE 31: 200 AMP TO 1200 AMP CT METERING, OVERHEAD SERVICE -----	55
FIGURE 32: 200 AMP TO 1200 AMP CT METERING, WITH SERVICE MASTS -----	56
FIGURE 33: 200 AMP TO 1200 AMP CT METERING, METER POLE -----	57
FIGURE 34: 200 AMP TO 1200 AMP CT METERING, METER POLE -----	59
FIGURE 35: WIRING OF TWO METERS, OVERHEAD SERVICE -----	62
FIGURE 36: WIRING OF TWO METERS, OVERHEAD SERVICE USING A STEEL SERVICE MAST -----	62
FIGURE 37: THREE TO SIX METERS, OVERHEAD SERVICE -----	65
FIGURE 38: UNDERGROUND SERVICE DETAIL -----	67
FIGURE 39: UNDERGROUND SERVICE DETAIL (CONTINUED) -----	68
FIGURE 40: UNDERGROUND SERVICE STRUCTURE -----	69
FIGURE 41: 200 AMP, UNDERGROUND SERVICE -----	72
FIGURE 42: 200 AMP METER SOCKET, UNDERGROUND SERVICE -----	73
FIGURE 43: 200 AMP METER SOCKET, NETWORK (120/208), UNDERGROUND SERVICE -----	74
FIGURE 44: 200 AMP COMBINATION METER SOCKET, UNDERGROUND SERVICE -----	75
FIGURE 45: 200 AMP COMBINATION METER SOCKET, NETWORK (120/208) UNDERGROUND SERVICE ---	76
FIGURE 46: 320 AMP METER SOCKET, UNDERGROUND SERVICE -----	77
FIGURE 46A: 320 AMP METER SOCKET, NETWORK (120/208), UNDERGROUND SERVICE -----	78
FIGURE 47: 320 AMP METER SOCKET, NETWORK (120/208), UNDERGROUND SERVICE -----	79
FIGURE 47A: 320 AMP COMBINATION METER SOCKET, NETWORK (120/208), UNDERGROUND SERVICE-	80
FIGURE 48: METER PEDESTAL -----	81
FIGURE 49: 400 AMP TO 800 AMP CT METERING, UNDERGROUND SERVICE -----	85
FIGURE 50: WIRING OF TWO METERS, UNDERGROUND SERVICE -----	88
FIGURE 51: THREE TO SIX METERS, UNDERGROUND SERVICE -----	89
FIGURE 51A: SEVEN OR MORE METERS, UNDERGROUND SERVICE -----	92
FIGURE 52: 200 AMP, UNDERGROUND SERVICE -----	93
FIGURE 53: 100/200 AMP METER SOCKET, UNDERGROUND SERVICE -----	94
FIGURE 54: POWER LEG CONNECTION ON 3 PHASE, 4 WIRE DELTA CONNECTED SYSTEMS -----	95
FIGURE 55: 400 AMP TO 1200 AMP CT METERING, UNDERGROUND SERVICE -----	99
FIGURE 56: WIRING OF TWO METERS, UNDERGROUND SERVICE -----	102

TABLE OF FIGURES

FIGURE 57: THREE TO SIX METERS, UNDERGROUND SERVICE-----	103
FIGURE 58: 3 PHASE PADMOUNT TRANSFORMER SERVING 1 CUSTOMER WITH METER ON TRANSFORMER -----	105
FIGURE 59: THREE PHASE PADMOUNT TRANSFORMER INSTALLATION -----	108
FIGURE 60: LARGE TRANSFORMER PAD, PHYSICAL SPECIFICATIONS -----	109
FIGURE 61: SMALL TRANSFORMER PAD, PHYSICAL SPECIFICATIONS -----	110
FIGURE 62: TRANSFORMER PAD REINFORCING BAR SPECIFICATIONS-----	111
FIGURE 63: TRANSFORMER PAD SPECIFICATIONS, CONCRETE & FOUNDATION DETAIL -----	112
FIGURE 64: TRANSFORMER CLEAR ZONE SPECIFICATIONS -----	113
FIGURE 65: GUARD POST INSTALLATION -----	114
FIGURE 66: MULTIPLE SERVICE POINT IDENTIFICATION PLAQUE -----	115

THIS PAGE INTENTIONALLY LEFT BLANK

THIS PAGE INTENTIONALLY LEFT BLANK

INTRODUCTION

Liberty Utilities and/or LU constantly strives to maintain a high standard of service to all Customers. This booklet has been prepared for use by Customers, architects, engineers, electrical contractors and local inspecting authorities so they may receive full benefit from our service. We believe you will find it helpful when planning new electrical installations, upgrading, or adding additional equipment. Copies are available at the Liberty Utilities Corporate office, service centers, and web site. All holders of Requirements for Electric Service and Meter Installations booklets are encouraged to submit comments to aid in future revisions. Please submit comments as follows:

1. Give section, paragraph and page number to which the comment pertains.
2. Submit comments in writing; giving details, sketches, drawings, and all supporting pertinent information.
3. Mail or Email to:

LIBERTY UTILITIES

Standards Engineering

PO Box 127

Joplin MO 64802

Email: Jeff.Brown@libertyutilities.com

The impression generally prevails that compliance with the National Electrical Code (NEC), or the various electrical ordinances guarantees to the Customer a wiring installation complete and adequate for the full use of electric service now and in the future. This is not necessarily the case. The NEC and these guidelines are designed to provide the minimum requirements considered necessary for safety. **(The NEC, Article 90-1(b) itself states, "Compliance therewith and proper maintenance will result in an installation essentially free from hazard, but not necessarily efficient, convenient or adequate for good service for future expansion of electrical use.")** Careful design and installation often results in a wiring system that exceeds NEC requirements.

LIBERTY UTILITIES, as a utility, must meet the requirements of the National Electrical Safety Code (NESC), which sometimes differ from the National Electrical Code (NEC).

The Company shall have the right to disconnect or refuse service to any installation which violates local, municipal, NEC or NESC regulations. The Company shall also have the right to disconnect or refuse service for installations that are hazardous to the public, or negatively impacts service to other Customers, or Company facilities.

Except for the installation and maintenance of its own property, Liberty Utilities does not install or repair wiring or equipment beyond the point of delivery. Therefore, LU is not responsible for the voltage levels beyond the point of delivery and does not assume any responsibility for Customer facilities beyond the point of delivery. Your cooperation will be greatly appreciated and will enable you to receive prompt and satisfactory service.

2.0 GENERAL INFORMATION

2.1 DEFINITIONS

Company	LIBERTY UTILITIES
Conduit	Pipe used to protect the electrical conductors. Rigid Steel or Schedule 80 Electrical Grade PVC is required on the wall when an underground service is provided.
Conduit Strap	A properly sized strap or clamp used with screws or nails to securely attach conduit to the structure.
Conduit Reducer	A fitting that provides a way to connect together different sized conduits.
Conduit Vent	A fitting used to provide an outlet so that gases or fluids can be released externally from the conduit. This is commonly used in hilly terrain.
Contribution-in-Aid of Construction	An amount to be paid to the Company by a Customer or developer when the Company has to install electrical facilities over and above what is normally required to provide service. This is required when the cost to serve is not justified by the expected revenue provided by the service.
Customer	User of the Company's electric service or user's authorized representative (architect, engineer, electrical contractor, etc.).
Drip Loop	Short length of the customer's service entrance conductors (wire) extending out of the weatherhead which allows connection to the Company's service drop.
Inspector or Inspection Authority	A person or agency authorized by a governmental body to inspect and approve electrical installations.
Interconnection-Cogeneration and Small Power Producers	An electric service where cogenerators and small power producers operate in parallel with the Company's electric system. Energy may flow in either direction through an interconnection.
Intersystem Ground Connector (Intersystem Bonding Termination)	A device that provides a means for connecting communications system(s), grounding conductor(s) and bonding conductor(s) at the service equipment or at the disconnecting means for buildings or structures supplied by a feeder or branch circuit.
Line of Sight	Is a straight line from the LU designated service source, i.e. Service Pole, Transformer Pole, Pad Mounted Transformer, Secondary Pedestal, etc. to the LU Point of Delivery.
Main Disconnect	This term as used in this document refers to a combination of a disconnecting and overcurrent protection device, e.g. fuse and manual switch or circuit breaker. LU recommends that a circuit breaker be used to accomplish this function. See Figure 3.
Maximum Available Fault Current (at the point of delivery)	The maximum current that would flow due to a direct short circuit from one conductor to ground or between conductors. This can be calculated by the company and furnished to the customer upon request.
Manufactured Home/Building	Shall be defined by the following requirements: The structure shall be installed on and secured to a permanent foundation. This does not mean block piers with cable or strap tie downs. The structural integrity of the manufactured home is sufficient to support the metered service equipment per NEC 550.32.

Meter Loop	Customer provided wire and enclosure connecting the Customer's service equipment to the Company's service drop. Consists of the following: Point of Attachment, wires, weatherhead, conduit, conduit straps, and meter socket / disconnect combination. These can be separate components.
Mobile Home	Shall be defined as any other type of structure moved to a site that does not match the Manufactured Building definition of this document.
NEC	The latest edition of the National Electrical Code.
NESC	The latest edition of the National Electrical Safety Code.
Point of Attachment	The point as designated by the Company at which the Company's service drop is attached to the Customer's facility, can be attached to the structure or to rigid steel conduit. It must be capable of withstanding a 200 pound continuous pull in the direction of the service drop and be electrically insulated from the structure.
Point of Delivery	The point as designated by the Company where the Company's facilities terminate at the Customer's facilities.
Readily Accessible	Capable of being reached quickly, for operation, renewal, or inspections without requiring those to whom ready access is a requisite to climb over or remove obstacles or resort to portable ladders, etc.
Self-Contained Meter Socket	A meter socket that is installed in line with the service entrance or lateral conductors. If the socket were replaced with conductor, the power could flow straight through to the service equipment.
Service	The supply by the Company of electricity to the Customer, including the readiness and availability of electrical energy at the point of delivery, at the standard available voltage whether or not utilized by the Customer.
Service Drop	The overhead service conductors between Company's last pole or other aerial support to and including the connectors to the service entrance conductors at the point of delivery to the Customer's property.
Service Entrance	Customer owned conductors and enclosures connecting the Customer's service equipment to the Company's service drop or service lateral.
Service Lateral	The underground service conductors between the Company's secondary pedestal or transformer, including any risers at a pole or other structure and the point of delivery.
Slip Joint	A fitting that provides a slip fit adjustment of PVC conduit extending from an electric service box on a building to an underground electric service line. The fitting allows for subsidence of the ground level without creating excessive force on the service box.
Sweep Elbow or ELL	Conduit Bend.
Undisturbed Earth	Soil that has not been moved by construction or recompacted soil that approximates such. In engineering terms, it is top soil or clay void of rotting debris that has been recompacted in 1 foot lifts to the desired level using a vibrating roller or sheeps-foot roller and achieving a 95% modified Proctor Density at each lift.
Wire Size	This refers to the AWG (American Wire Gauge) designation of copper wire unless otherwise specified. Should another approved conductor material be used, a size having the equivalent current carrying capacity shall be selected.

DEFINITIONS ONLY

REFER TO INSTALLATION SPECIFICATION AND FIGURES FOR CONSTRUCTION DETAILS.

Meter Loop - Customer provided wire and enclosure connecting the customer's service equipment to the Company's service drop. Consists of the following: **Point of Attachment, wires, weatherhead, conduit, conduit straps, and meter socket.**

Point of Attachment - The point as *designated by the Company* at which the Company's service drop is attached to the Customer's facility. Can be attached to the structure or to rigid steel conduit. It must be capable of withstanding a 200 pound continuous pull in the direction of the service drop and be electrically insulated from the structure.

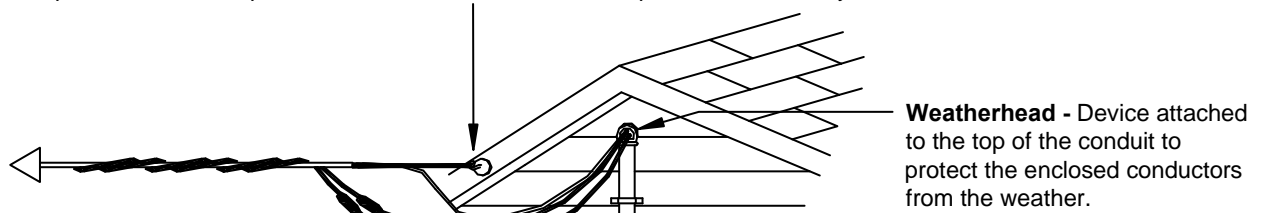

Weatherhead - Device attached to the top of the conduit to protect the enclosed conductors from the weather.

Conduit Strap - properly sized strap used with screws or nails to securely attach conduit to the structure.

Conduit - Pipe used to protect the electrical conductors.

Drip Loop - Short length of the customer's service entrance conductors (wire) extending out of the weatherhead which allows connection to the Company's service drop.

Meter - Company provided device to measure energy consumption.

Self-Contained Meter Socket - Often called the "Meter Base". **Customer provided** enclosure that holds the Company's metering device.

Main Disconnect - Customer provided device by which conductors of a service circuit can be disconnected from their source of energy. The disconnect shall be located on the exterior of the structure either as a combination socket or a separate disconnect. If more than one disconnect is required, they shall all be placed at this location.

Intersystem Ground Connector - A connector block designed to provide a grounding path so that others, i.e. cable TV, telephone, may have easy access to ground bonding. This is as per NEC 250.94 (3).

Ground Rod Clamp - Clamp specifically designed to connect ground wire to ground rod.

Ground Wire - Referred to as "Grounding Electrode Conductor" by the NEC. Conductor used to connect the Ground Rod to the meter socket grounding connector at the service entrance. It must be securely attached to the structure.

Ground Rod - Referred to as a "Grounding Electrode" by the NEC. Copper clad steel rod, 5/8" x 8', driven in undisturbed earth as close to the service entrance as possible.

08/27/19 - KMH 12/30/04 - SDS REVISIONS			DEFINITIONS	
	DRAWN: JEB	DWG. NO. G18A2089		
	SCALE: NTS	DATE: 5/13/96	FIGURE 1	

Figure 1: Definitions

DEFINITIONS ONLY

**REFER TO INSTALLATION SPECIFICATION AND FIGURES
FOR CONSTRUCTION DETAILS.**

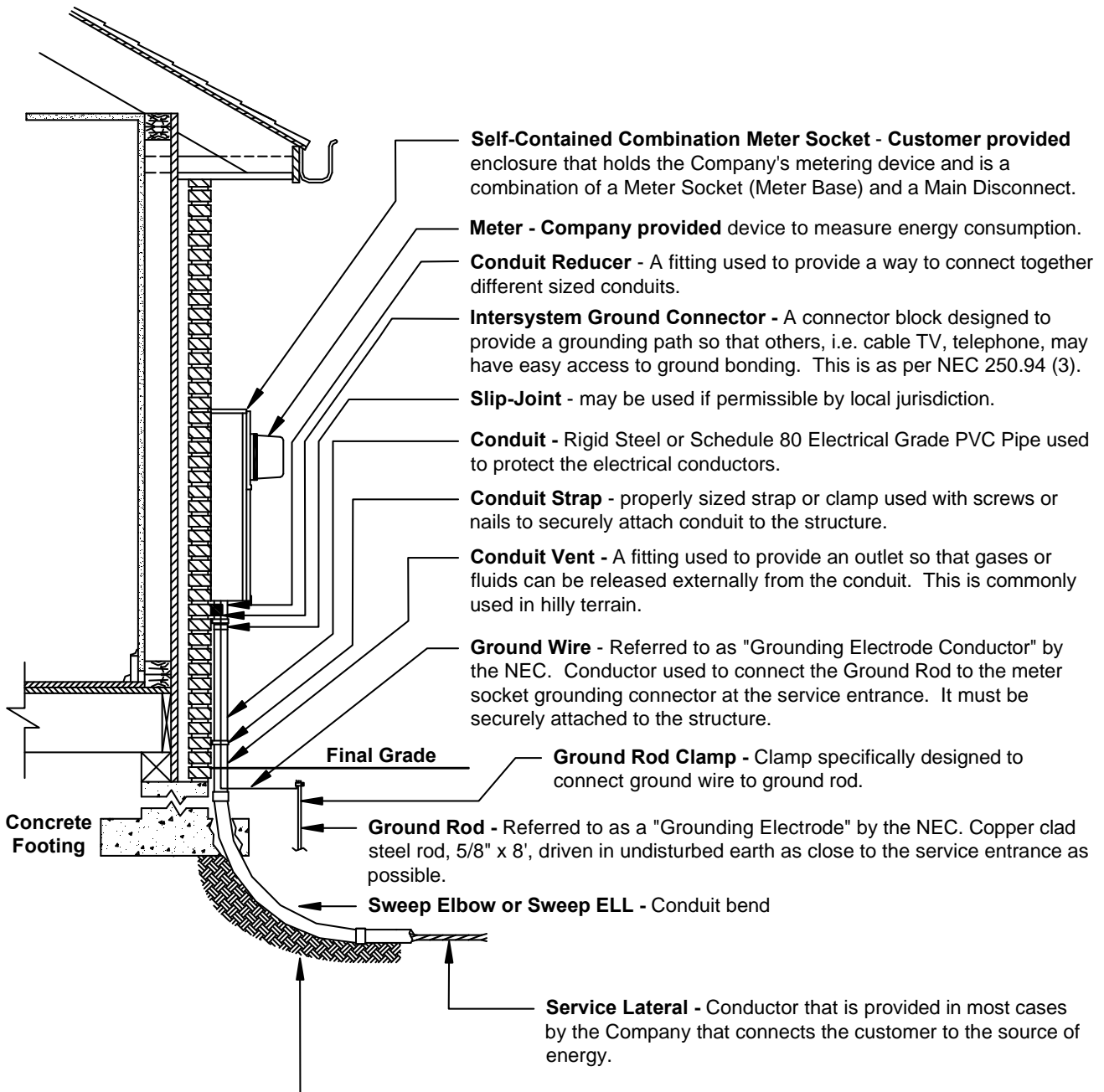

Undisturbed Earth - Soil that has not been moved by construction or recompacted soil that approximates such. In engineering terms, it is top soil or clay void of rotting debris that has been recompacted in 1 foot lifts to the desired level using a vibrating roller or sheeps-foot roller and achieving a 95% modified Proctor Density at each lift.

08/27/19 KMH	01/26/09 SDS	REVISIONS		DEFINITIONS	
				DRAWN: SDS	DWG. NO. G18A2090
			SCALE: NTS	FIGURE 2	
			DATE: 11/06/06		

Figure 2: Definitions

2.2 AVAILABILITY AND LOCATION OF SERVICE

Before construction is started, the Customer shall request the Company to designate a point of delivery, and submit appropriate load data to the Company. The load data should include the anticipated demand and list of equipment. The Customer shall provide a set of building plans, a survey and a copy of the warranty deed. It is requested that the Customer provide the building plans as an AutoCAD file (.DWG) format.

It is important that the Company and Customer be in agreement on the planned location of all service-related equipment before construction is started. This equipment includes, but may not be limited to; meter sockets, risers, pedestals, conduit and trench location, pull boxes, padmounted transformers, CT/connection cabinets, pole, lines and anchors.

The Customer is responsible to contact customer service to submit a Request for Service. Customer Service can be reached by calling: (800) 206 – 2300.

Failure to comply could result in time delays and/or additional cost to the Customer.

2.3 TYPE AND CHARACTER OF SERVICE

1. It is essential that the customer consult the Company regarding the type of service which can be furnished at a particular location before proceeding with purchase of equipment or installation of wiring.
2. The voltage and/or number of phases which will be supplied will depend on the type, size and location of the load, and existing Company facilities.
 - a. The table below lists the standard service voltages that are available.

	SINGLE PHASE	THREE PHASE
Pole Mounted Transformer	120/240 Volts, 3-Wire Up to 167 KVA 120/208 Volts, 3-Wire (Limited Applications)	240/120 Volts, 4-Wire DELTA ^Φ Up to 75 KVA 208/120 Volts, 4-Wire WYE* Up to 500 KVA 480/277 Volts, 4-Wire WYE* Up to 500 KVA
Pad Mounted Transformer	120/240 Volts, 3-Wire Up to 167 KVA	208/120 Volts, 4-wire WYE* Up to 1000 KVA 480/277 Volts, 4-Wire WYE* Up to 2500 KVA

Note:

^Φ The Company **will not** provide a 240/120 volt, four-wire delta service when the surrounding area is served by an underground primary distribution system or service is required from a padmounted transformer. The maximum single position transformer size is 25 kVA.

* All wye services require a neutral conductor.

b. In some instances, three-phase service at the primary voltage of 7,200/12,470 volts Grd Y or 2,400/4,160 volts Grd Y may be provided. However, this service must be approved by the Company.

3. The manner in which single-phase loads are connected by the Customer is critical when **three-phase four-wire WYE** service is provided. All single-phase loads should be split evenly among the three phases. Connections made otherwise may result in an overload or single-phase condition with the possibility of damage to the Customer's three-phase equipment.
4. The manner in which single-phase loads are connected by the Customer is critical when **three-phase four-wire DELTA** service is provided. No single-phase loads should be connected to the power leg. Inappropriate connections of single phase equipment to the power leg may result in damage to the connected equipment. The Customer shall provide a load schedule detailing the three phase and single phase loads to be served.
5. **The Customer is responsible for providing the necessary equipment and devices to protect any three phase equipment from damage due to a single phasing condition that may occur on the Company's service.**
6. All single phase motors over 6.5 hp and all three phase motors over 15 hp must be approved in advance by the Company. If an adjustable speed drive or DC drive is used, the Customer shall notify the Company so that characteristics particular to the solid state motor control can be taken into account in all studies.

2.4 GENERAL REQUIREMENTS

1. The Customer's wiring and electrical equipment shall be safe, in conformance with the NEC and with all applicable federal, state, and local codes and ordinances.
2. The Main Disconnect ampacity determines the wire size used in the Service Riser as well as the wire size from the Meter Socket to the Main Disconnect.
3. All wiring installations must be inspected and approved by an authorized electrical inspector as required by governmental authority.

The Company shall have the right to disconnect or refuse service to any installation which violates local, municipal, NEC or NESC regulations. The Company shall also have the right to disconnect or refuse service for installations that are hazardous to the public, or negatively impacts service to other Customers, or Company facilities.

4. The Customer's equipment (motors, welders, etc.) shall operate so as not to impose a voltage drop on the Company's primary system that will exceed the Company's flicker curve limitations. The Customer shall be responsible for the necessary modifications to the equipment to correct the problem.
5. For all 3 phase, 4 wire, wye services supplied by the Customer, a full rated neutral (Grounded Conductor) shall be provided unless the Customer provides documentation from a registered engineer allowing derating of the neutral (Grounded Conductor).
6. Before service can be connected, the 911 address must be displayed at the location.

2.5 ALTERATIONS AND ADDITIONS

1. **SERVICE CONNECTIONS, METERS, OR METERING EQUIPMENT SHALL NOT BE REMOVED OR RELOCATED EXCEPT BY EMPLOYEES OF THE COMPANY OR ITS AUTHORIZED AGENTS.**
2. Connection to the Customer's premises is made with facilities designed to properly supply adequate electric service for the Customer's operation using information provided at the time of application for service. Therefore, no additions of major load, or alterations of the Customer's installation should be made without first notifying the Company. Failure to provide such notification may affect the quality and reliability of the Customer's own service, as well as that of other Customers.
3. When alterations or repairs require the relocation or temporary removal of service drop wires, meters and metering equipment, the Customer shall make appropriate advance arrangements with the Company to perform the relocation or temporary removal. The new location must be approved by the Company before the Customer begins work. All alterations or repairs must meet the applicable codes that are in effect at the time work is done. When alterations or repairs have been satisfactorily completed by the Customer and the necessary inspection approvals obtained, the Company will make the connections to provide service.

4. **Since *serious injury or death* could result from a person coming in contact with an energized electrical circuit or equipment, neither the Customer nor the Customer's agents shall remove an energized meter from its socket. Meters are not designed to be a disconnecting device under load. Arcing, fire, explosion, etc. could occur with the possibility of burns, injury, or death as well as damage to adjacent or surrounding structures and equipment. The Customer will be held legally responsible for such injury, death, or damage if caused by the unauthorized breaking of the seals, tampering, or otherwise interfering with the Company's meter or other equipment of the Company installed on the Customer's premises. No one except authorized employees or agents of the Company will be allowed to make any repairs or adjustments to any meter or other equipment belonging to the Company. The Company will be responsible for disconnecting service and removing the meter prior to the Customer's repair or replacement of the Customer's meter socket.**

3.0 METERING

3.1 GROUNDING

1. GENERAL

Unless otherwise noted, the Customer shall supply and install a 5/8" x 8' ground rod with ground rod clamp outside of the building wall. It shall be totally driven and be within two (2) feet of the structure at the meter socket location. If other grounding methods are used, all grounding systems must be bonded together as per NEC.

2. SELF – CONTAINED

When using self-contained meter sockets, the ground wire shall originate at the factory installed grounding connector in the meter socket and terminate at the ground rod clamp on the ground rod. The size of the ground wire shall be as specified in the applicable drawings.

3. CURRENT TRANSFORMER (CT)

When the metering installation requires the use of current transformers, a single ground rod may not be adequate. Consult the NEC for further information.

4. Minimum Ground Wire

For a 200 Amp service or less, refer to the tables in the applicable drawings. For a service larger than 200 Amp, consult the NEC.

3.2 METERING EQUIPMENT LOCATIONS

1. The metering equipment shall be located outdoors and approved by the Company.
2. Metering equipment shall be located where it is readily accessible to Company employees without special keys or entry requirements (public entry).
3. Metering accuracy is of utmost importance to the Company and its Customers. Therefore, any location where the environment could affect the accuracy of the meter will not be acceptable. These conditions could include, but are not limited to: corrosion, vibration, dust, magnetic interference, etc.

4.0 INFORMATION APPLYING TO ALL SERVICES

1. There will only be one service voltage available at a location, and only one point of delivery for each building, except as allowed by the NEC and approved by the Company. If multiple service points are approved by the Company, the service points shall be marked as per NEC 230.2.E. Engraved plaques shall be attached with screws, bolts, or rivets. See Figure 66 for plaque details.
2. **The point of delivery shall be designated by the Company prior to beginning construction.**
3. **All utilities must be notified and all underground facilities located and marked prior to any excavation. This shall include any Customer owned facilities.**
4. All service entrance facilities, including meter sockets, shall be located in an exposed and readily accessible area.
5. **Copper conductors are highly recommended.** Where allowed by local authority, aluminum conductors may be installed per NEC requirement; provided the meter socket is approved for use with aluminum conductors, and a corrosion inhibiting compound recommended by the cable manufacturer is properly applied to the meter socket terminals. **Conductor ampacities used in the wire tables are based on 75 degrees C as per NEC 310.15(B)(16).**
6. When an existing service entrance using copper conductors is replaced by a service entrance using aluminum conductors, the existing meter socket, if not marked AL-CU, must be replaced with one approved for use with aluminum conductors.
7. Service entrance conductors between the Company's point of delivery and the self-contained metering point, or the first disconnect shall be enclosed in conduit. **Troughs and electrical gutters are not allowed on either side of disconnects on the outside of the building.**
8. Unless otherwise noted, the conduit is to be galvanized rigid steel. **Water pipes, sewer pipes and/or fittings are NOT acceptable.** Unless otherwise stated all sweep ells shall be rigid steel, and the following minimum sweep radius of these will be; 4" – 16", 3" –13", and 2" – 9.5".
9. The neutral conductors of all services shall be grounded at the metering point as shown on the applicable drawings.
10. Conductor marking
 - a. All neutral conductors shall be clearly marked with white tape at the point of delivery and at the meter location.
 - b. The power leg of each 240/120 volt, three-phase, four-wire delta service shall be clearly marked with orange tape at the point of delivery and at the meter location.
11. Phase Rotation

On three-phase installations to insure proper equipment operation, the Customer is responsible for verifying phase rotation at the time of service connection.

THIS PAGE INTENTIONALLY LEFT BLANK

5.0 TEMPORARY SERVICES

1. The Company must be provided with detailed plans of each installation where temporary service is to be supplied. Installations requiring special service, meter, or other work for construction purposes, exhibits of short duration, etc., **will be made at the expense of the Customer.**
 2. Temporary services over 300 feet are not available. **The Company will not be responsible for damage done to equipment with temporary services.**
 3. **Temporary service equipment shall not be installed on trees or the Company's Poles.**
 4. Temporary installation of service entrance, other wiring, and meters shall meet the same requirements as permanent installations, including inspection and approval.
 5. **Temporary single phase service for construction purposes may be provided from either overhead or underground facilities. Arrangements for temporary construction service are shown in Figures 4, 5, and 6.**
 6. Prior to connection of permanent service, all temporary service drops or temporary construction wires or cables shall be removed from the finished structure's permanent distribution panels.
 7. The typical temporary service is 120/240v, single phase. Single phase temporary service requiring over 100 amps capacity and three phase temporary may be available. Contact the Company for more details, additional costs may apply.
- 8. All temporary installations shall be safe and in good working condition as judged by a Company field representative before the service will be connected.**
9. Temporary service will be available at the site as long as construction is in progress or is otherwise limited by the Local Authority. Once the project is substantially completed the temporary service shall be disconnected.
 10. LU is not required to provide electric service to temporary Customers at locations that require the extension of Company lines unless the full cost of erection and removal, including indirect costs of construction, of the extension be contributed by the Customer.

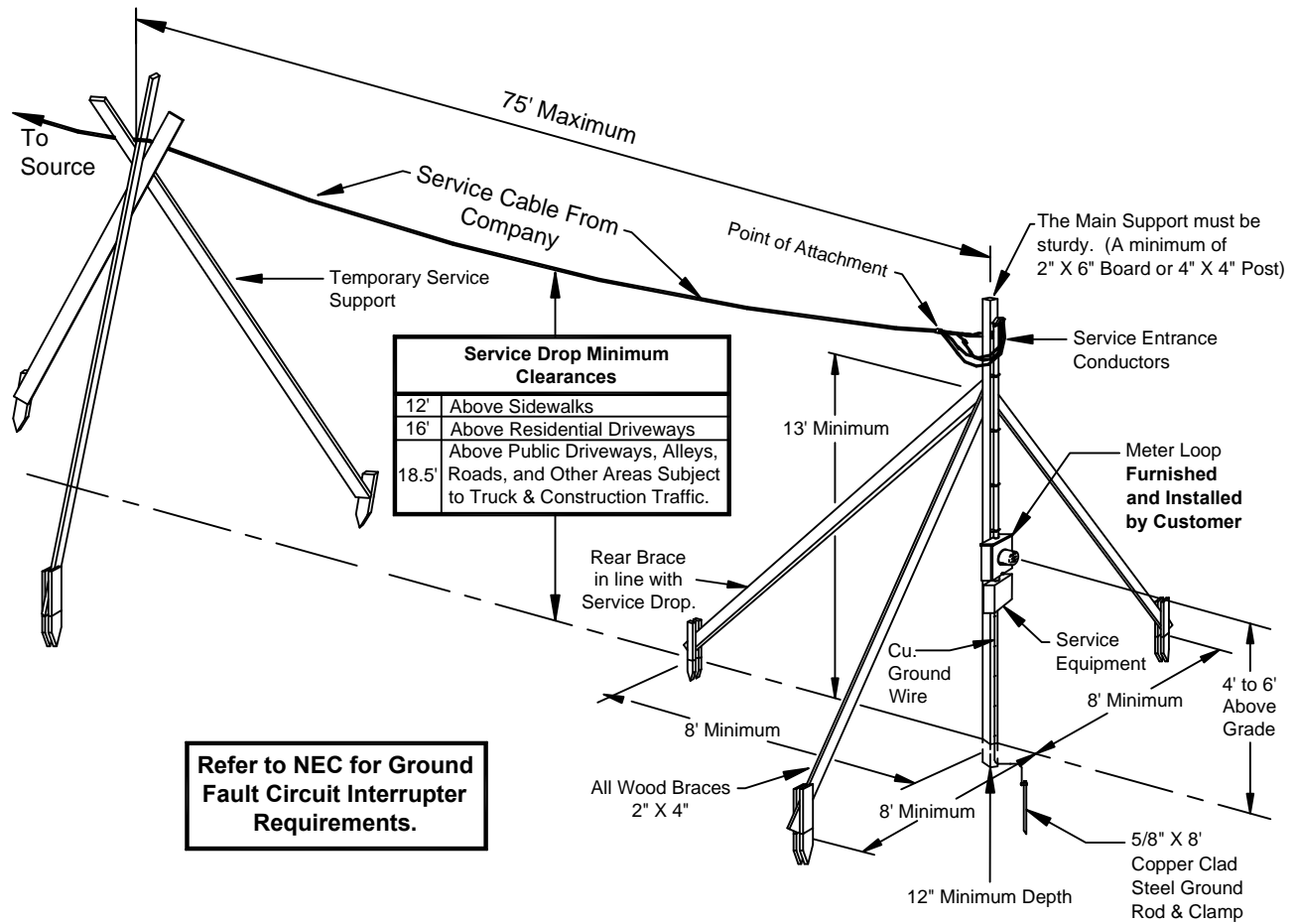

Service Drop Minimum Clearances	
12'	Above Sidewalks
16'	Above Residential Driveways
18.5'	Above Public Driveways, Alleys, Roads, and Other Areas Subject to Truck & Construction Traffic.

Refer to NEC for Ground Fault Circuit Interrupter Requirements.

CAUTION!
Contact All Utilities
Before Digging or Staking.

All Equipment Furnished and Installed By Customer Unless Otherwise Noted.

Service Size	Wire Sizes	
	Neutral*	Line
100 Amp	#4 Cu.	#4 Cu.
	#2 AL.	#2 AL.

* Neutral May Be Reduced Under Specific Conditions Allowed By NEC

Service Size	Ground Wire
100 Amp	#6 Cu.

07/09/19 KMH 07/15/06 SDS REVISIONS		Temporary Service From Overhead Facilities	
		DRAWN: LU	DWG. NO. G18A2092
		SCALE: NTS	FIGURE 4
		DATE: 01/01/96	

Figure 4: Temporary Service from Overhead Facilities

Service Size	Minimum	
	Neutral*	Line
100 Amp	#4 Cu.	#4 Cu.
	#2 AL.	#2 AL.

* Neutral May Be Reduced Under Specific Conditions Allowed By NEC.

Refer to NEC for Ground Fault Circuit Interrupter Requirements.

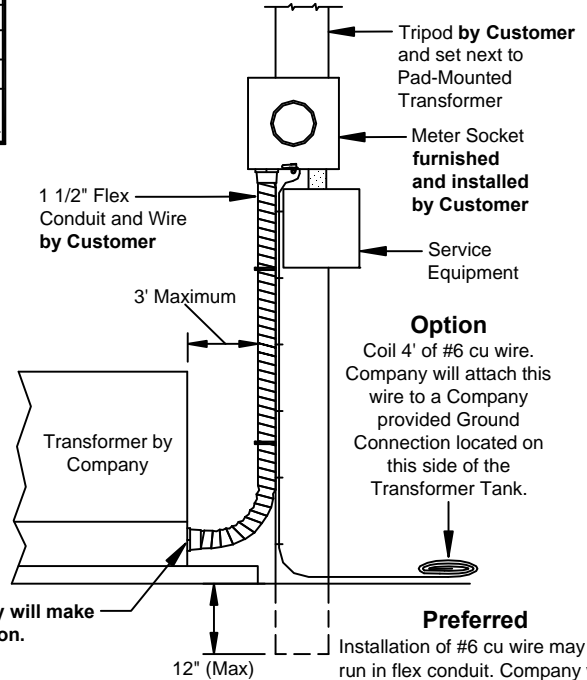
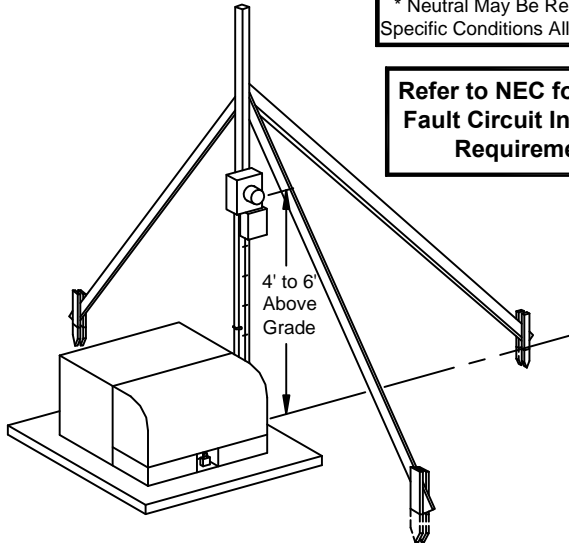

Preferred
Installation of #6 cu wire may be run in flex conduit. Company will attach this wire to a Company provided Ground.

Temporary Meter Loop Shall Be As Shown.

CAUTION!
Contact All Utilities Before Digging or Staking.

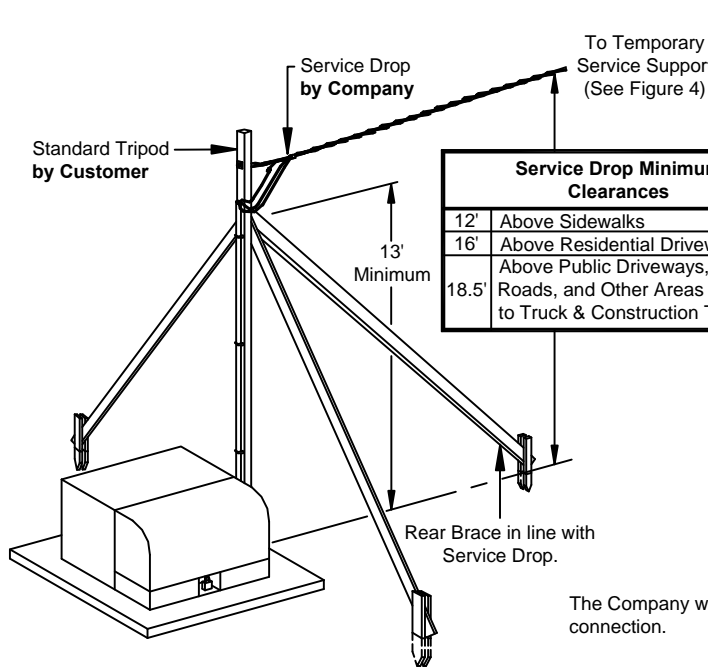

Service Drop Minimum Clearances	
12'	Above Sidewalks
16'	Above Residential Driveways
18.5'	Above Public Driveways, Alleys, Roads, and Other Areas Subject to Truck & Construction Traffic.

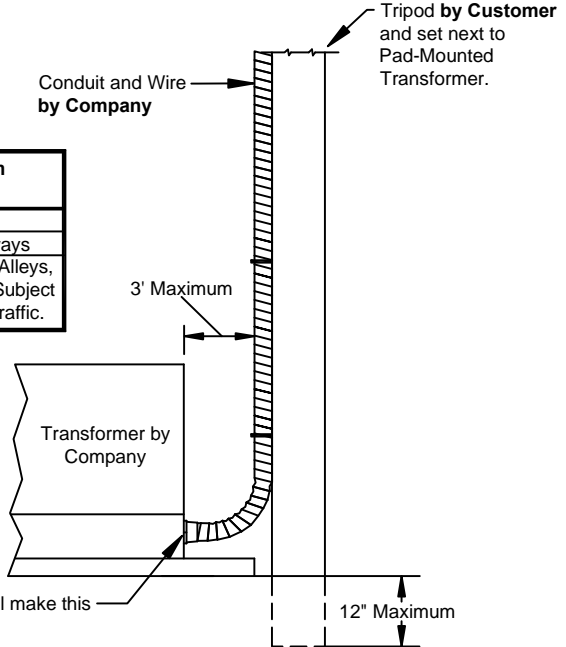

All Equipment Furnished and Installed By Customer Unless Otherwise Noted.

07/09/19 KMH
07/15/06 SDS
REVISIONS



Temporary Service From Underground Facilities	
DRAWN: LU	DWG. NO. G18A2093
SCALE: NTS	FIGURE 5
DATE: 01/01/97	

Figure 5: Temporary Service from Underground Facilities

Service Size	Minimum	
	Neutral*	Line
100 Amp	#4 Cu.	#4 Cu.
	#2 AL.	#2 AL.

* Neutral May Be Reduced Under Specific Conditions Allowed By NEC.

Refer to NEC for Ground Fault Circuit Interrupter Requirements.

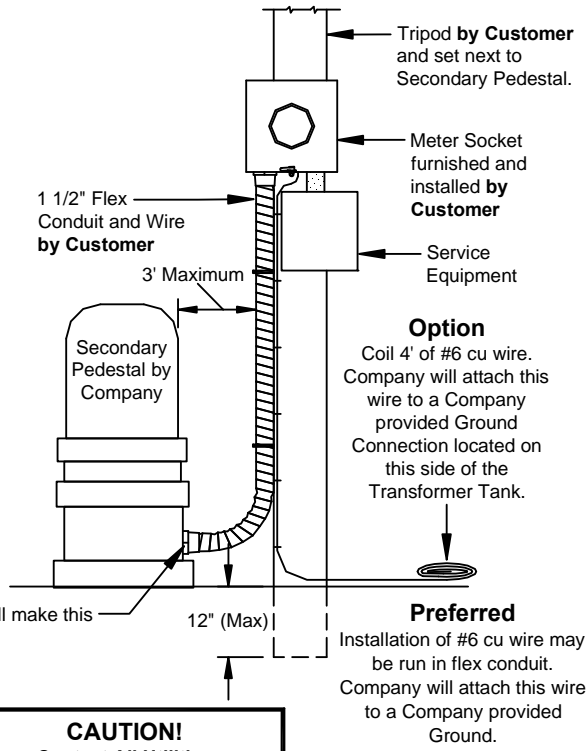
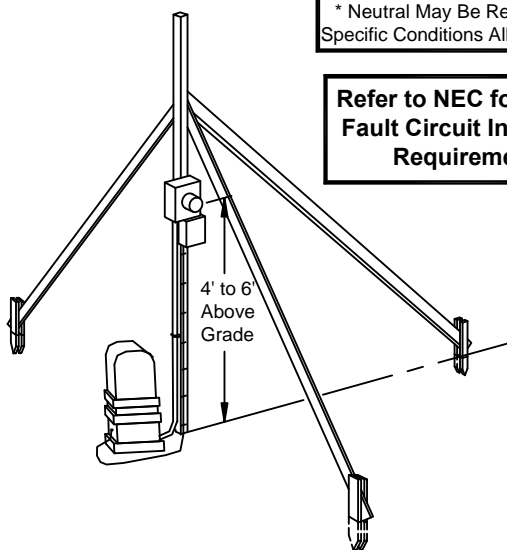

Temporary Meter Loop Shall Be As Shown.

CAUTION!
Contact All Utilities Before Digging or Staking.

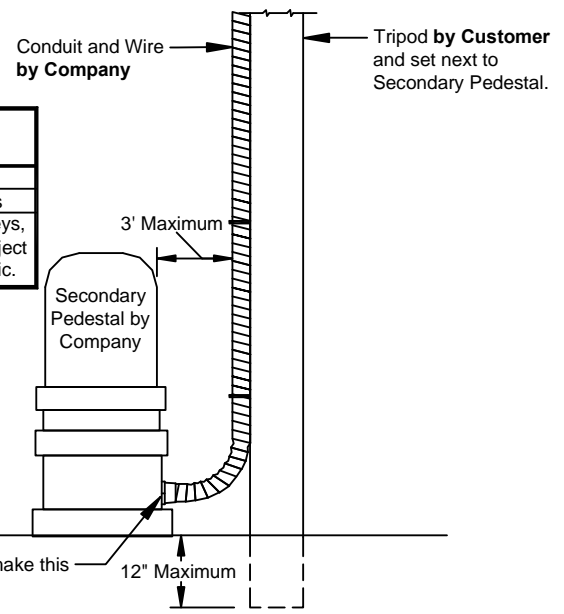
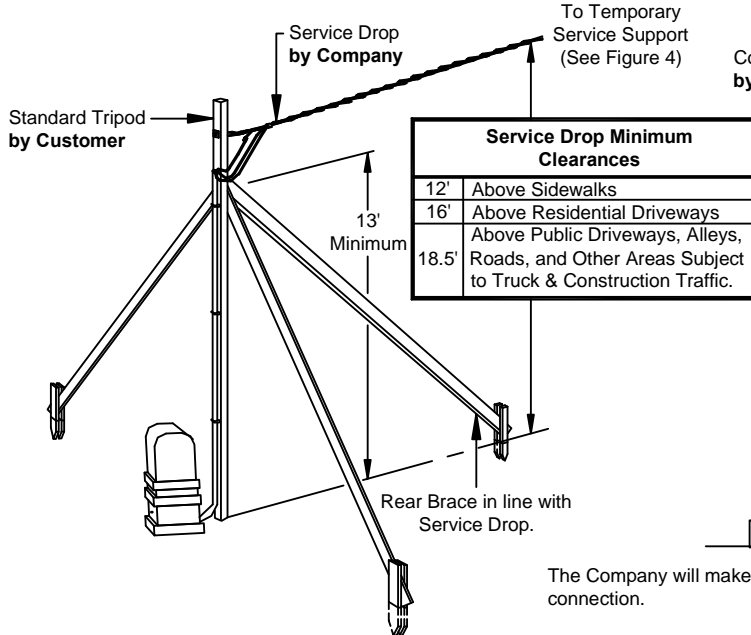

All Equipment Furnished and Installed By Customer Unless Otherwise Noted.

07/09/19 KMH
07/15/06 SDS
REVISIONS



Temporary Service From Underground Facilities (continued)	
DRAWN: LU	DWG. NO. G18A2094
SCALE: NTS	FIGURE 6
DATE: 01/01/97	

Figure 6: Temporary Service from Underground Facilities (Continued)

RESERVED FOR FUTURE USE

Figure 7: FUTURE

6.0 OVERHEAD SERVICES

6.1 GENERAL INFORMATION

1. The Customer shall provide an insulated Point of Attachment within 24" of the weatherhead which is capable of withstanding a continuous force of 200 lbs. in the direction of pull of the Service Drop. The weatherhead shall be above the point of attachment, where practical. The weatherhead location shall not be farther than 24 inches from the Point of Attachment.
2. A minimum of 24 inches of service entrance conductor shall extend from a single weatherhead for connection to the service drop. **If the installation requires more than one service riser, it is the responsibility of the Customer to provide enough conductor so that a single connection point per phase can be made at one common location.**
3. The Customer shall provide a clear and unobstructed path for the Company's service drop to the attachment point. The Customer shall request the Company to designate the location of the point of delivery for each service location before construction is started. This shall be done to increase the reliability of electric service. Trees growing into or near power lines are one of the most common causes of power outages. Help avoid the need for future trimming by planting the right tree in the right place. For a list of appropriate trees for the TALL ZONE, MEDIUM ZONE AND LOW ZONE pictured below, please contact your LU representative.

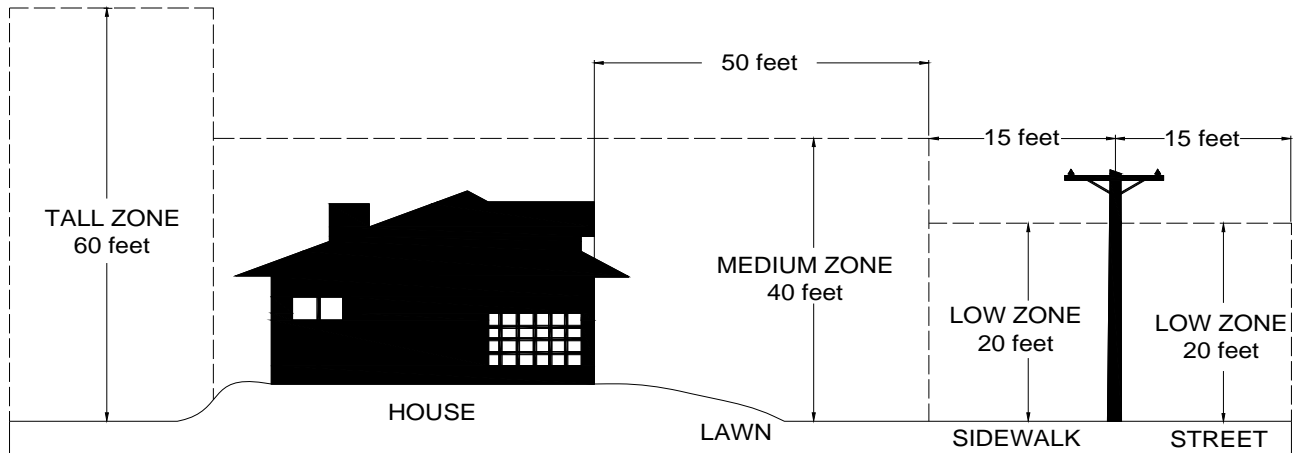

4. The point of attachment of the service drop conductors shall be located by the Customer so as to allow not less than the minimum clearances for the service drop as shown in the table below. Greater clearances may be required by local authorities. **In no case shall the attachment height be lower than 12' above final grade.**

MINIMUM CLEARANCES OF SERVICE DROP CABLES*

Above roads, streets, alleys, parking lots, commercial and industrial driveways subject to truck traffic	18.5 feet
Above residential driveways	16 feet
Above space accessible to pedestrians only(including decks and porches)....	12 feet
Above or below roofs or balconies accessible to pedestrians.....	11 feet
Above or below roofs or projections not accessible to pedestrians.....	8 feet
Horizontal to any structure.....	5 feet
Horizontal from directly below conductor to edge of swimming pool.....	10 feet

(This is for either an above ground or in ground swimming pool.)

*Note: The point of attachment shall normally be 2' - 3' higher than these minimum required clearances to allow for sag of the service cable.

5. Street access driveways, where vehicular traffic may pass under service conductors, must maintain the minimum clearances from ground to service conductors required for roads, streets, alleys, and parking lots in the above table. For further details and items not covered above, contact the Company.

6. The point of delivery will be at the weatherhead connections.

6.2 100 AMP, 200 AMP, AND 320 AMP SINGLE PHASE OVERHEAD SERVICES

A. General Notes:

1. Service entrance conductors, 5/8" x 8' copper clad steel ground rod, ground rod clamp, ground wire, conduit, conduit straps, weatherhead, lock nuts, bushings, meter socket, meter socket hub, service drop attachment device, and miscellaneous mounting hardware furnished and installed by the Customer.
2. Meter, service connectors, and service drop furnished and installed by Company.
3. The meter socket should be "readily accessible" (see definitions). The Company requires a level and unobstructed work space of 78 inches tall, 18 inches on either side and 48 inches in front of the meter socket. Prior approval is required for placement of the meter socket in alleyways or areas where it may be subjected to damage.
4. The 100 Amp, 200 Amp and 320 Amp meter sockets shall meet the following specifications:
 - a. The latest revision of U.L. 414 and ANSI C12.7 Standards.
 - b. Must be U.L. listed.
 - c. Must have grounding connector for triplex.
 - d. Lug size – 2/0 minimum.
 - e. On 120/208v services, the customer must provide the meter socket with 5th lug installed in the 9 o'clock position.
 - f. **See Appendix A for list of approved meter sockets.**
5. Installation requiring a steel service mast shall be installed by the Customer as specified in Figure 9.

B. Mounting:

1. Meter socket, ground wire, and conduit shall be surface mounted and securely fastened to the structure. The meter socket shall be installed in a level and plumb position. **Flush mounted or recessed metering equipment and service riser conduit embedded in a wall will not be permitted.**
2. Where the exterior wall is other than brick or concrete blocks, a supporting frame shall be installed behind the exterior wall to provide a solid mounting surface for the meter socket.
3. Meter sockets, metering cabinets, and conduit straps shall be installed with the following:
 - a. Lead anchors or double helix concrete screws shall be used with brick or solid concrete surfaces.
 - b. Toggle bolts shall be used with other masonry siding.
 - c. Wood screws shall be used with solid wood surfaces.
 - d. All mounting hardware shall be minimum #12(1/4") corrosion resistant screws.
 - e. A minimum of 4 fasteners shall be used to install any socket or cabinet unless specifically stated otherwise.
4. An intersystem bonding termination bar shall be installed to facilitate the connection of other utility's ground to a common ground. The location of this device shall be located directly below the meter socket or meter combination socket.
 - a. **See Appendix A for list of approved intersystem bonding termination bars.**
5. Wire not enclosed in conduit shall be a minimum of 36 inches away from any window or door opening.

C. Connections:

1. Do not score line or load wire when removing insulation.
2. The Customer shall use wire brush or sandpaper to clean all conductors, apply a non-grit type inhibitor and tighten to manufacturer's specifications.

D. Conductor Marking:

All neutral conductors shall be clearly marked with white tape at the point of delivery and at the meter socket.

Minimum Attachment Height shall be 12' above final grade. The Customer shall provide an insulated Point of Attachment within 24" of the Weatherhead which is capable of withstanding a continuous force of 200 lbs. in the direction of pull of the Service Drop.

A minimum of 24" of wire shall be provided **by the Customer**. The Neutral shall be marked with white tape. The wire shall be marked or listed as Sunlight Resistant as per NEC 310.10 (D).

The path to the Service Pole shall be clear of trees and building debris and materials.

Company Service Drop and Connectors

Service Drop Minimum Clearances	
12'	Above Ground
16'	Above Residential Driveways
18.5'	Above Public Driveways, Alleys, Roads, and Other Areas Subject to Truck & Construction Traffic.

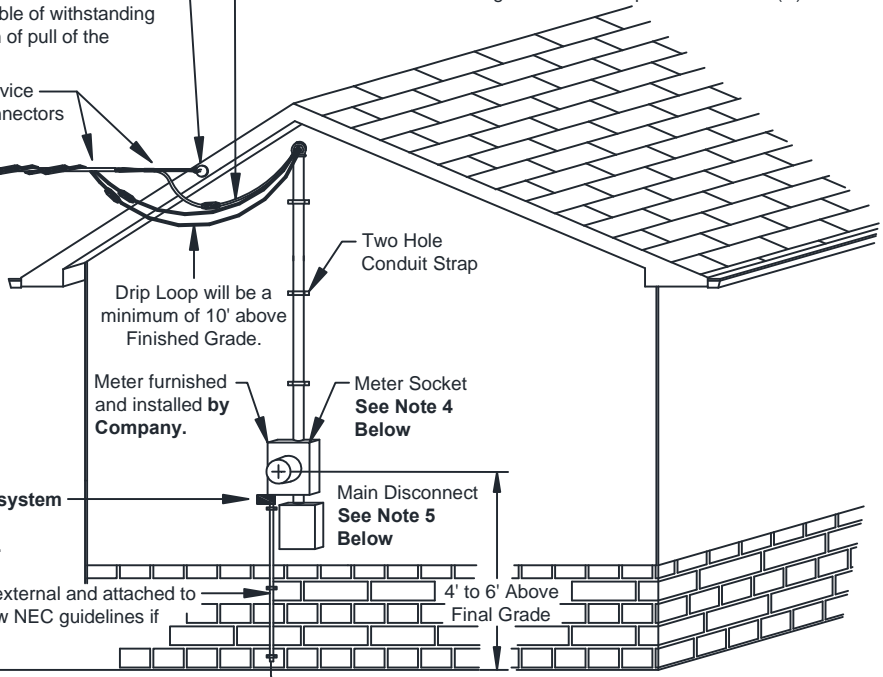

This wire shall be external and attached to the building. Follow NEC guidelines if Conduit is used.

Service Size	Ground Wire
100 Amp	#6 Cu.
200 Amp	#4 Cu.
320 Amp	1/0 Cu.

Ground Rod Clamp

All Grounding Systems shall be bonded together.

5/8" X 8' Copper Clad Steel Ground Rod installed external to Building.

Service Size	Wire Sizes		Conduit Size	Conduit Type ***
	Neutral**	Line		
100 Amp*	#3 Cu.	#3 Cu.	1 1/4 "	Galv. Rigid Steel
	#1 AL.	#1 AL.	1 1/2 "	Galv. Rigid Steel
200 Amp	3/0 Cu.	3/0 Cu.	2 "	Galv. Rigid Steel
	250 AL.	250 AL.	2 1/2 "	Galv. Rigid Steel
320 Amp	2 - 4/0 Cu.	2 - 4/0 Cu.	3 "	Galv. Rigid Steel
	2 - 300 AL.	2 - 300 AL.	4 "	Galv. Rigid Steel

* 100 Amp allowed on overhead service only.
 ** Neutral May Be Reduced Under Specific Conditions Allowed By NEC.
 *** Other types of conduit allowed depending on local code.

Ground Rod and Wire MUST be Installed and Ground Wire MUST be attached to the structure before Service will be Connected.

Notes:

1. If minimum vertical clearance cannot be maintained with the installation of an attachment as shown above, the **Customer** shall install a rigid steel service mast as shown in Figure 9.
2. Connections between the Service Drop and Service Entrance Conductors shall be made **by Company Personnel** below the Weatherhead, forming a Drip Loop.
3. Other types of conduit may be allowed depending on Local Code Requirements. These may include EMT, Electrical Grade PVC, and Rigid Aluminum. **However, the Service Drop shall not be attached to any of these.**
4. 100 amp, 200 amp and 320 amp meter sockets shall be furnished **by the customer**. Bypass lever allowed on 320 amp meter socket only.
5. The disconnect shall be located on the exterior of the structure either as a combination socket or an separate disconnect. If more than one disconnect is required, they shall all be placed at this location. It shall not be closer than 1" nor farther than 1' from the meter socket.

All Equipment Furnished and Installed By Customer Unless Otherwise Noted.

07/31/20	TDK
01/29/20	SMS
08/27/19	KMH
03/18/10	SDS
07/10/09	SDS
07/15/06	SDS
05/17/05	SDS
01/01/97	AMA
REVISIONS	



100/200/320 Amp Overhead Service	
DRAWN: LU	DWG. NO. G18A2096
SCALE: NTS	FIGURE 8
DATE: 01/01/95	

Figure 8: 100/200/320 Amp Overhead Service

Insulated Wire Holder Bracket supplied by Customer.

Weatherhead
A minimum of 24" of wire shall be provided by the Customer. The Neutral shall be marked with white tape. The wire shall be marked or listed as Sunlight Resistant as per NEC 310.10 (D).

The path to the Service Pole shall be clear of trees and building debris and materials.

Sealing Compound is suggested.
Metal Flashing or Roof Lining Tube with Rain Diverter is suggested.

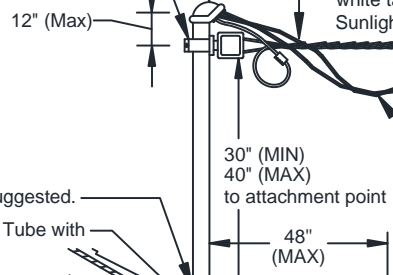

Company Service Drop and Connectors
Drip Loop will be a minimum of 10' above Finished Grade.

Service Drop Minimum Clearances	
12'	Above Sidewalks
16'	Above Residential Driveways
18.5'	Above Public Driveways, Alleys, Roads, and Other Areas Subject to Truck & Construction Traffic.

A Conduit Coupling will NOT be allowed above this point.

Two Hole Conduit Strap

Service Size	Wire Sizes		Conduit Size	Conduit Type
	Neutral**	Line		
100 Amp*	#3 Cu.	#3 Cu.	2"	Galv. Rigid Steel
	#1 AL.	#1 AL.	2"	Galv. Rigid Steel
200 Amp	3/0 Cu.	3/0 Cu.	2"	Galv. Rigid Steel
	250 AL.	250 AL.	2 1/2"	Galv. Rigid Steel
320 Amp	2 - 4/0 Cu.	2 - 4/0 Cu.	3"	Galv. Rigid Steel
	2 - 300 AL.	2 - 300 AL.	4"	Galv. Rigid Steel

* 100 Amp allowed on overhead service only.
** Neutral May Be Reduced Under Specific Conditions Allowed By NEC.

Where the exterior wall is other than brick or concrete blocks, a supporting frame shall be installed behind the exterior wall to provide a solid mounting surface for the meter socket.

Install Intersystem Ground Connector.

Meter furnished and installed by Company.
Meter Socket 100 amp and 200 amp meter sockets shall be furnished by the Customer.

Ground Rod and Wire MUST be Installed and Ground Wire MUST be attached to the structure before Service will be Connected.

Main Disconnect The disconnect shall be located on the exterior of the structure. If more than one disconnect is required, they shall all be placed at the same location. It shall not be closer than 1" nor farther than 1' from the meter socket.

4' to 6' Above Final Grade

This wire shall be external and attached to the building. Follow NEC Guidelines if Conduit is used.

Service Size	Ground Wire
100 Amp	#6 Cu.
200 Amp	#4 Cu.
320 Amp	1/0 Cu.

FINAL GRADE OR DECK ELEVATION



All Grounding Systems shall be bonded together.

Ground Rod Clamp

All Equipment Furnished and Installed By Customer Unless Otherwise Noted.

07/31/20	TDK
08/09/19	KMH
07/10/09	SDS
07/15/06	SDS
05/17/05	SDS
01/01/97	AMA
REVISIONS	



100/200/320 Amp Steel Service Mast	
DRAWN: LU	DWG. NO. G18A2097
SCALE: NTS	FIGURE 9
DATE: 01/01/95	

Figure 9: 100/200/300 Amp Steel Service Mast

Service Size	Wire Sizes	
	Neutral**	Line
100 Amp*	#3 Cu.	#3 Cu.
	#1 AL.	#1 AL.
200 Amp	3/0 Cu.	3/0 Cu.
	250 AL.	250 AL.

* 100 Amp allowed on overhead service only.
 ** Neutral May Be Reduced Under Specific Conditions Allowed By NEC.

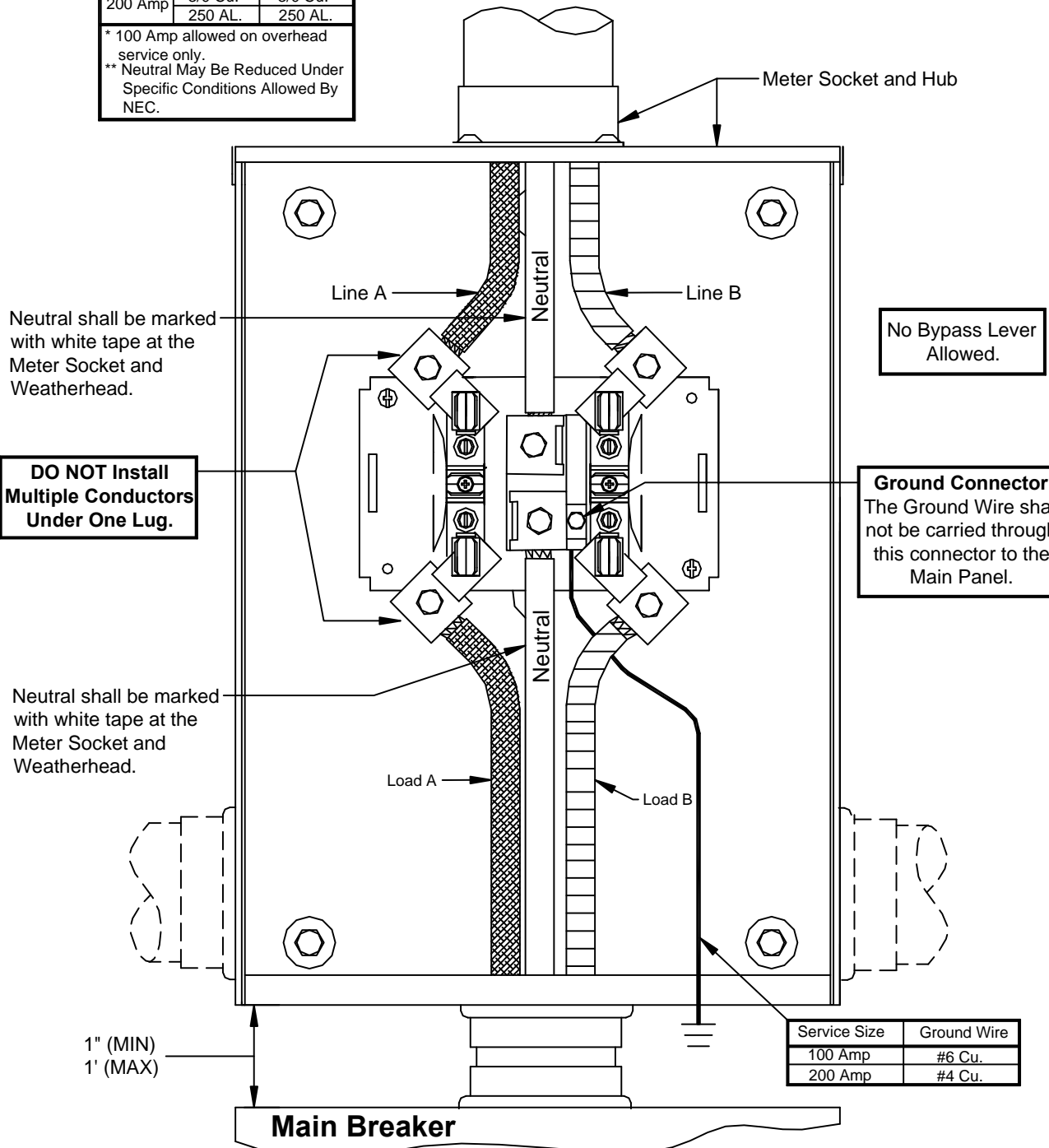

DO NOT Install Multiple Conductors Under One Lug.

No Bypass Lever Allowed.

Ground Connector
 The Ground Wire shall not be carried through this connector to the Main Panel.

Service Size	Ground Wire
100 Amp	#6 Cu.
200 Amp	#4 Cu.

All Equipment Furnished and Installed By Customer Unless Otherwise Noted.

07/09/19 KMH
 07/10/09 SDS
 05/17/05 SDS
 01/01/97 AMA
 REVISIONS



100/200 Amp Meter Socket, Overhead Service
 DRAWN: LU DWG. NO. G18A2098
 SCALE: NTS
 DATE: 01/01/95

FIGURE 10

Figure 10: 100/200 Amp Meter Socket, Overhead Service

Service Size	Wire Sizes	
	Neutral**	Line
100 Amp*	#3 Cu.	#3 Cu.
	#1 AL.	#1 AL.
200 Amp	3/0 Cu.	3/0 Cu.
	250 AL.	250 AL.

* 100 Amp allowed on overhead service only.
 ** Neutral May Be Reduced Under Specific Conditions Allowed By NEC.

Note:
 This application for
 120/208v, 3 wire service.

Neutral shall be marked with white tape at Meter Socket and Weatherhead.

This wire must have white insulation and will be connected as shown. This wire will be provided and installed by the Customer on **Approved Meter Sockets**.

The Customer will provide and install the 5th lug on **Approved Meter Sockets**. For a list of these, refer to **Appendix A**.

DO NOT Install Multiple Conductors Under One Lug.

Neutral shall be marked with white tape at Meter Socket and Weatherhead.

No Bypass Lever Allowed.

Ground Connector
 The Ground Wire shall not be carried through this connector to the Main Panel.

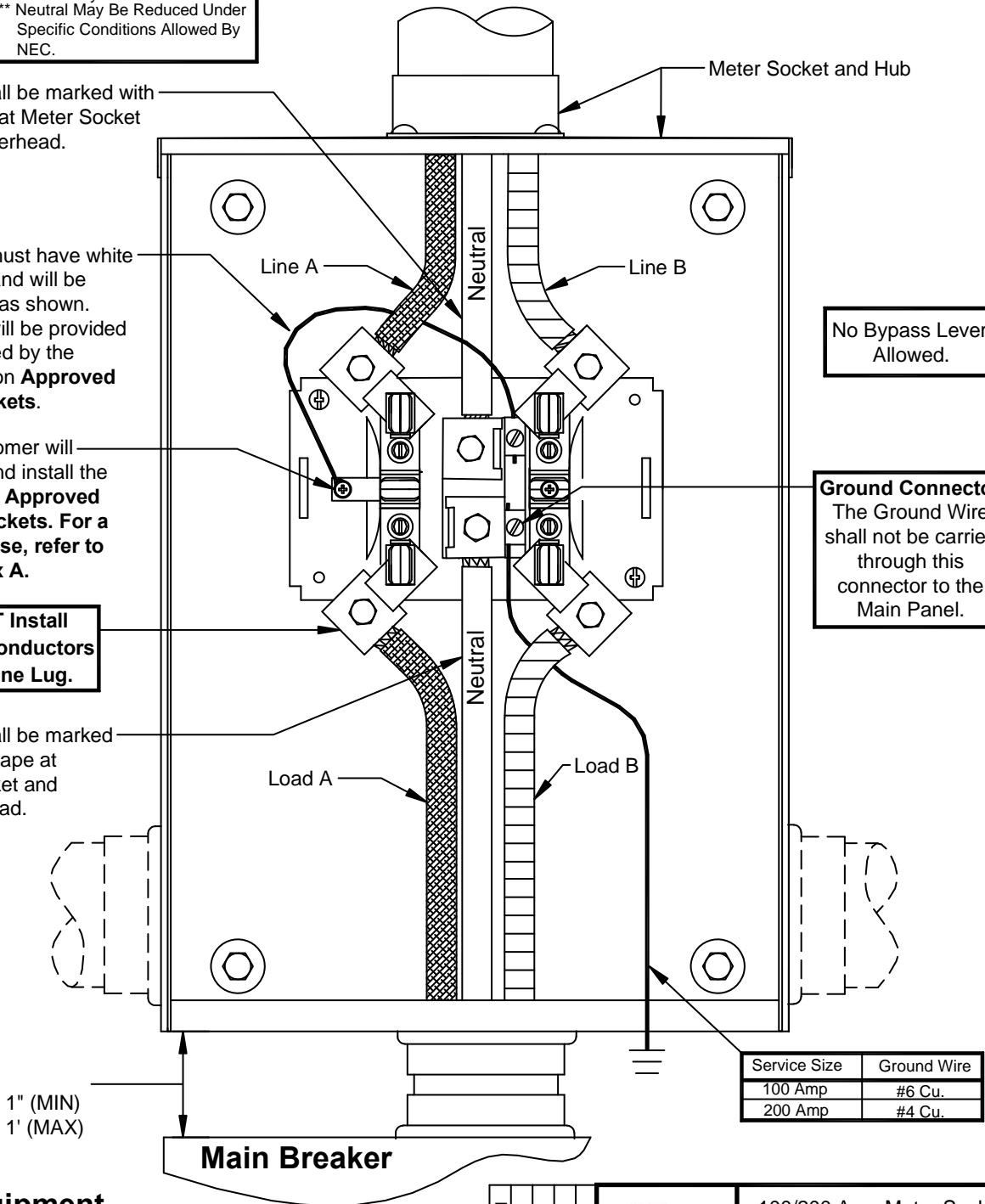

Service Size	Ground Wire
100 Amp	#6 Cu.
200 Amp	#4 Cu.

**All Equipment
 Furnished and Installed By
 Customer Unless Otherwise Noted.**

07/09/19 KMH
 07/10/09 SDS
 07/15/06 SDS
 05/17/05 SDS
 REVISIONS



100/200 Amp Meter Socket, Network (120/208) Service
 DRAWN: LU DWG. NO. G18A2099
 SCALE: NTS
 DATE: 07/01/97 FIGURE 11

Figure 11: 100/200 Amp Meter Socket, Network (120/208) Overhead Service

Service Size	Wire Sizes	
	Neutral**	Line
100 Amp*	#3 Cu.	#3 Cu.
	#1 AL.	#1 AL.
200 Amp	3/0 Cu.	3/0 Cu.
	250 AL.	250 AL.

* 100 Amp allowed on overhead service only.
 ** Neutral May Be Reduced Under Specific Conditions Allowed By NEC.

DO NOT Install Multiple Conductors Under One Lug.

DO NOT Install Multiple Conductors Under One Lug.

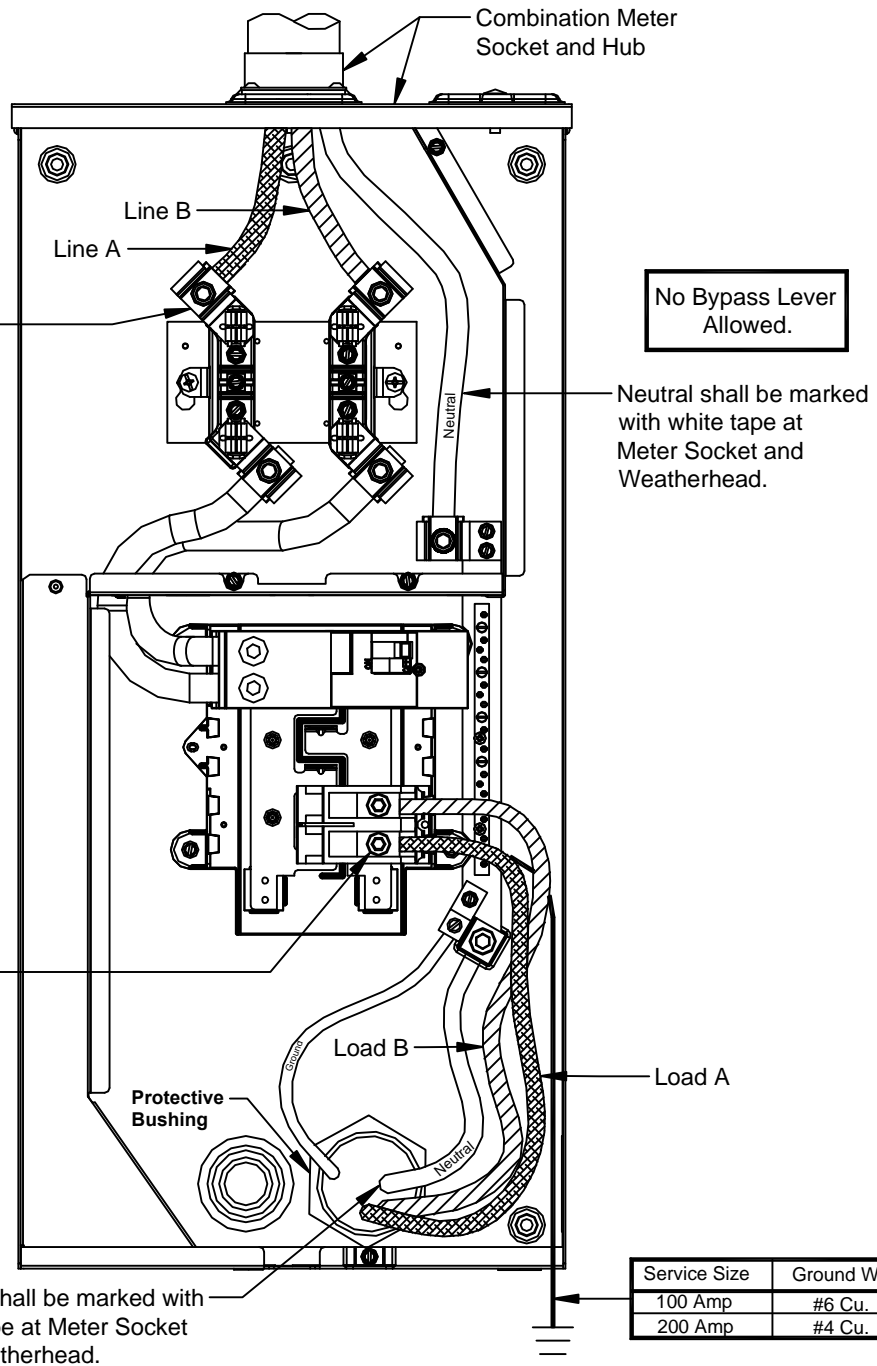

Service Size	Ground Wire
100 Amp	#6 Cu.
200 Amp	#4 Cu.

Neutral shall be marked with white tape at Meter Socket and Weatherhead.

All Equipment Furnished and Installed By Customer Unless Otherwise Noted.

08/09/19 KMH
 07/10/09 SDS
 REVISIONS



100/200 Amp Combination Meter Socket	
DRAWN: LU	DWG. NO. G18A2100
SCALE: NTS	FIGURE 12
DATE: 11/10/06	

Figure 12: 100/200 Amp Combination Meter Socket

Note:
This application for 120/208v, 3 wire service.

Service Size	Wire Sizes	
	Neutral**	Line
100 Amp*	#3 Cu.	#3 Cu.
	#1 AL.	#1 AL.
200 Amp	3/0 Cu.	3/0 Cu.
	250 AL.	250 AL.

* 100 Amp allowed on overhead service only.
 ** Neutral May Be Reduced Under Specific Conditions Allowed By NEC.

DO NOT Install Multiple Conductors Under One Lug.

This wire must have white insulation and will be connected as shown. This wire will be provided and installed by the Customer on **Approved Meter Sockets.**

The Customer will provide and install the 5th lug on **Approved Meter Sockets.** For a list of these, refer to Appendix A.

DO NOT Install Multiple Conductors Under One Lug.

Neutral shall be marked with white tape at Meter Socket.

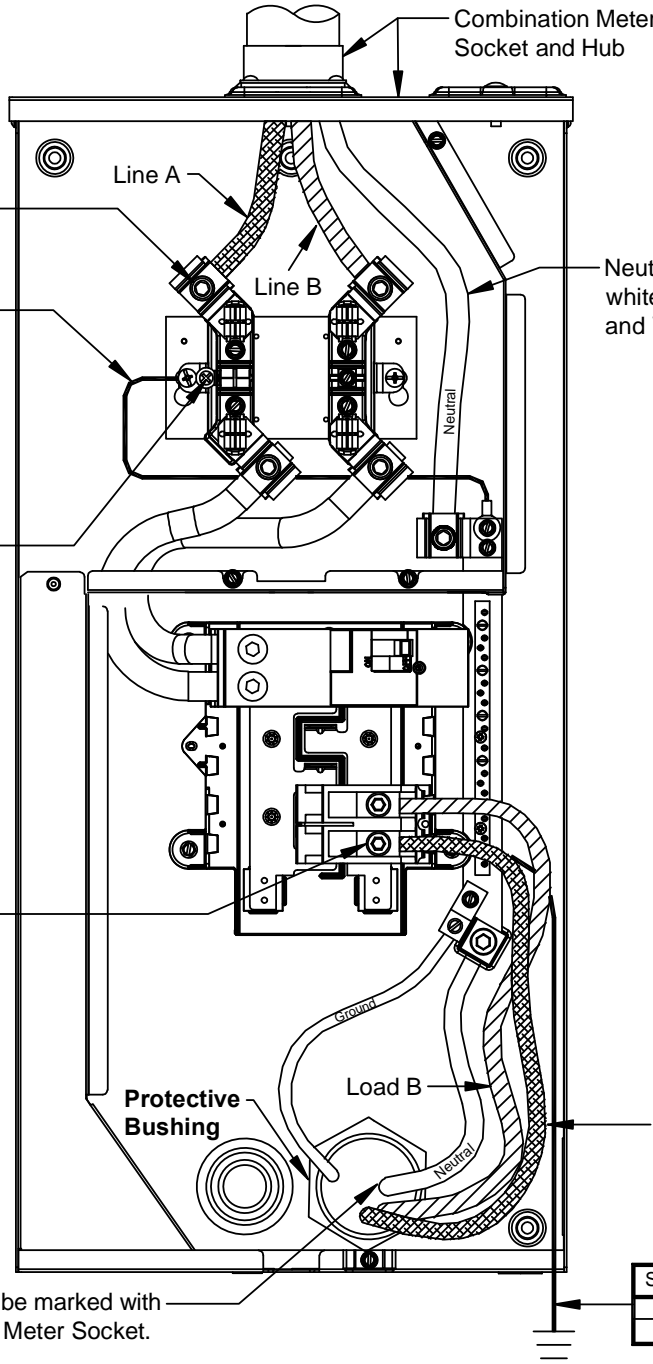

Neutral shall be marked with white tape at Meter Socket and Weatherhead.

Service Size	Ground Wire
100 Amp	#6 Cu.
200 Amp	#4 Cu.

All Equipment Furnished and Installed By Customer Unless Otherwise Noted.

06/11/20 SMS	REVISIONS
08/09/19 KMH	
07/10/09 SDS	

100/200 Amp Combination Meter Socket, Network (120/208) Service	
DRAWN: LU	DWG. NO. G18A2101
SCALE: NTS	FIGURE 13
DATE: 11/10/06	

Figure 13: 100/200 Amp Combination Meter Socket, Network (120/208) Overhead Service

Wire Sizes		
Service Size	Neutral*	Line
320 Amp	2 - 4/0 Cu.	2 - 4/0 Cu.
	2 - 300 AL.	2 - 300 AL.

* Neutral may be reduced under specific conditions allowed by NEC.

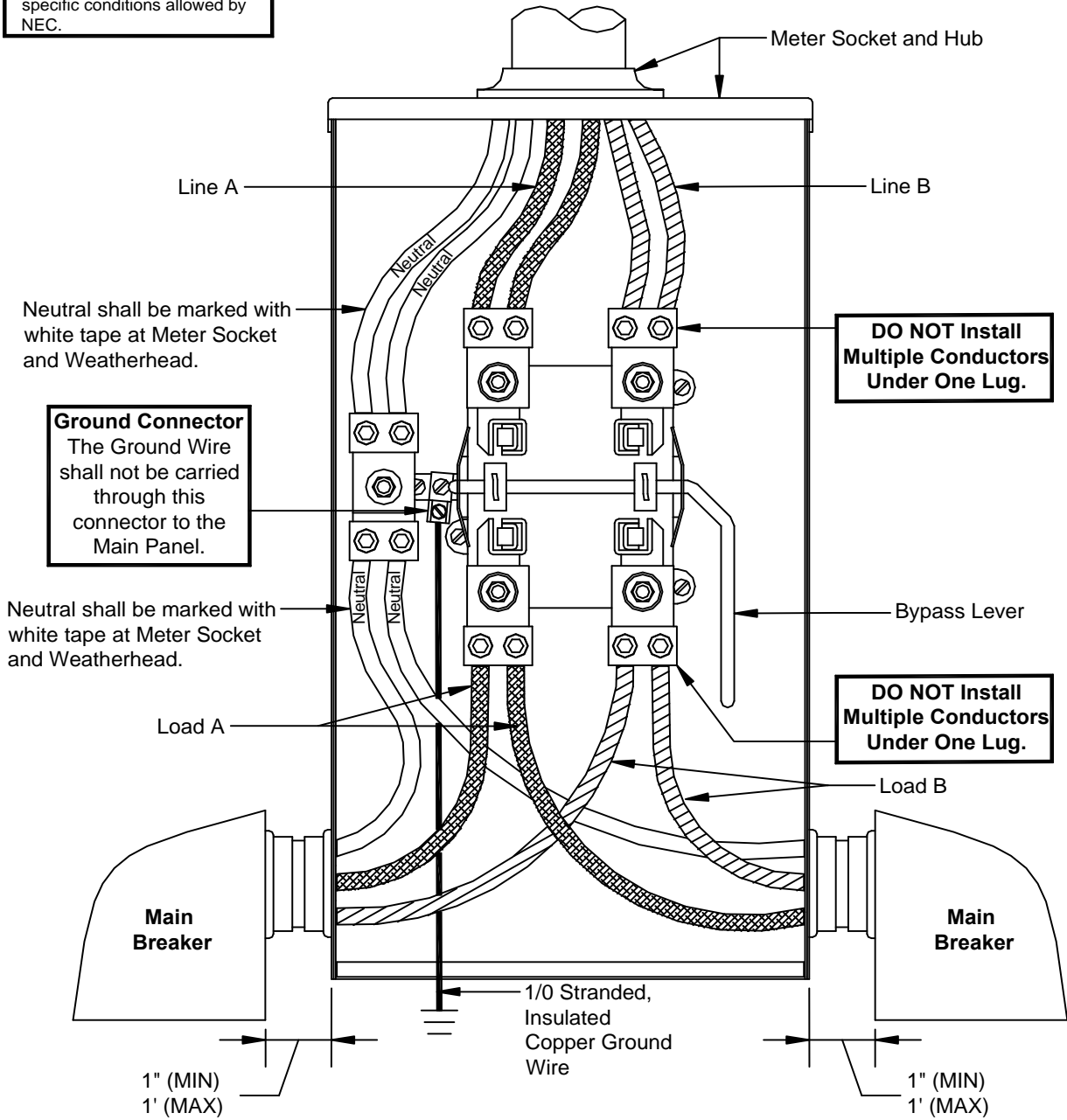

All Equipment Furnished and Installed By Customer Unless Otherwise Noted.

05/11/18	KMH
03/18/10	SDS
07/09/09	SDS
05/17/05	SDS
01/01/97	AMA
REVISIONS	



320 Amp Meter Socket, Overhead Service	
DRAWN: LU	DWG. NO. G18A2097
SCALE: NTS	FIGURE 14
DATE: 01/01/95	

Figure 14: 320 Amp Meter Socket, Overhead Service

Wire Sizes		
Service Size	Neutral*	Line
320 Amp	2 - 4/0 Cu.	2 - 4/0 Cu.
	2 - 300 AL	2 - 300 AL

* Neutral may be reduced under specific conditions allowed by NEC.

Note:
This application for 120/208v, 3 wire service.

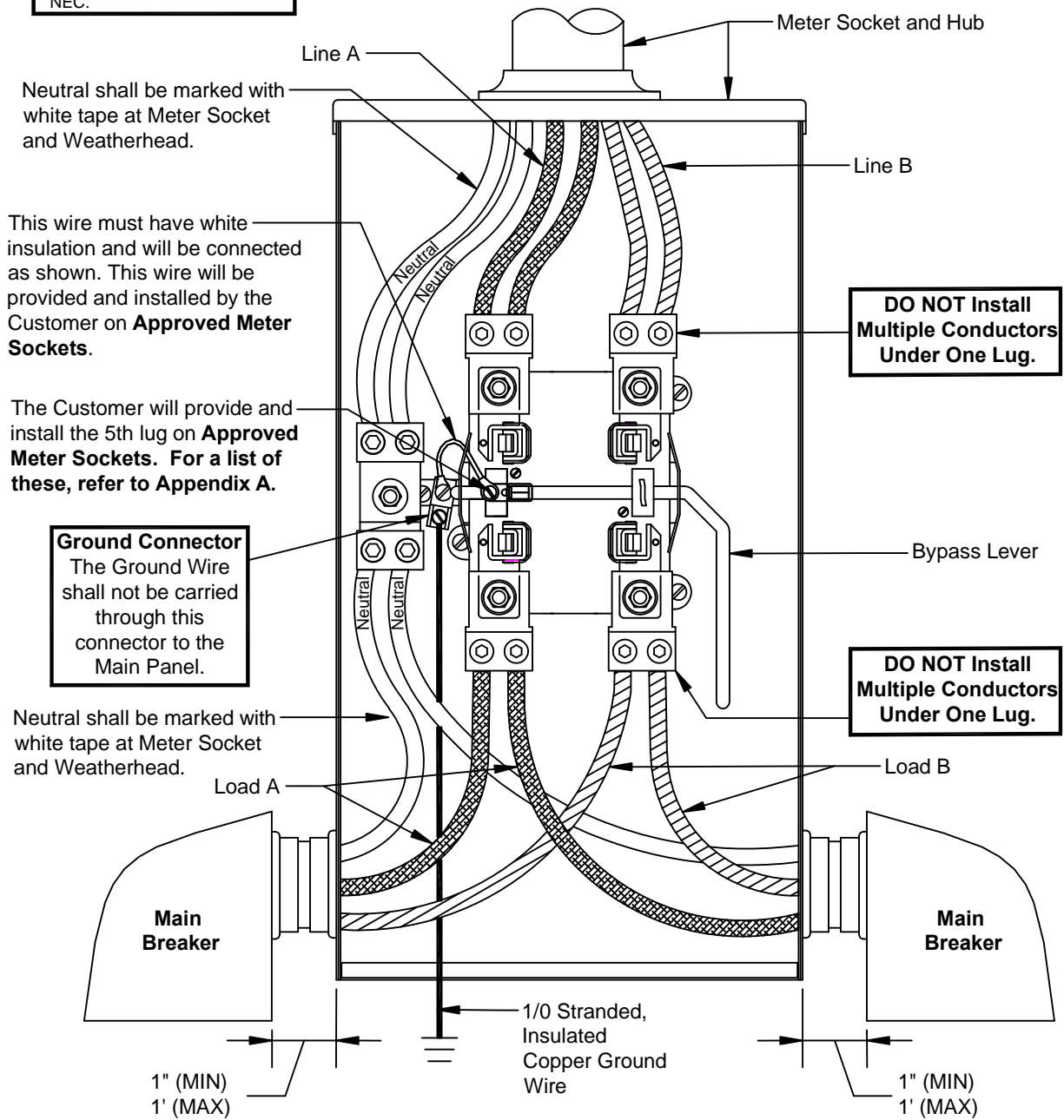

Neutral shall be marked with white tape at Meter Socket and Weatherhead.

This wire must have white insulation and will be connected as shown. This wire will be provided and installed by the Customer on **Approved Meter Sockets**.

The Customer will provide and install the 5th lug on **Approved Meter Sockets**. For a list of these, refer to **Appendix A**.

Ground Connector
 The Ground Wire shall not be carried through this connector to the Main Panel.

Neutral shall be marked with white tape at Meter Socket and Weatherhead.

All Equipment Furnished and Installed By Customer Unless Otherwise Noted.

06/11/20 SMS REVISIONS		320 Amp Meter Socket, Network (120/208), Overhead Service	
		DRAWN: KMH	DWG. NO. G18A2097A
		SCALE: NTS	FIGURE 14A
		DATE: 08/05/19	

Figure 14A: 320 Amp Meter Socket, Network (120/208), Overhead Service

Wire Sizes		
Service Size	Neutral*	Line
320 Amp	2 - 4/0 Cu.	2 - 4/0 Cu.
	2 - 300 AL	2 - 300 AL

* Neutral may be reduced under specific conditions allowed by NEC.

DO NOT Install Multiple Conductors Under One Lug.

DO NOT Install Multiple Conductors Under One Lug.

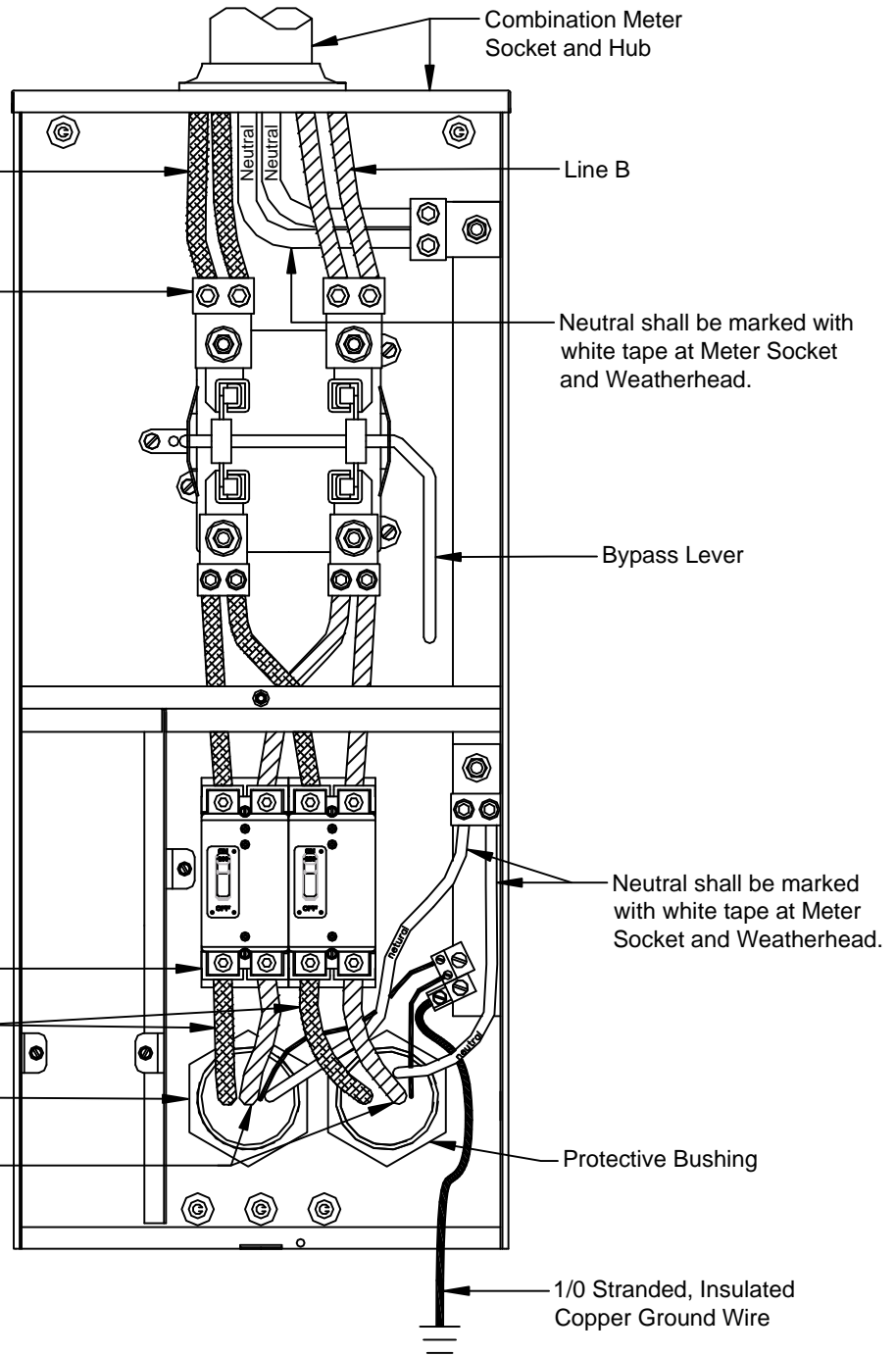

All Equipment Furnished and Installed By Customer Unless Otherwise Noted.

08/05/19 KMH REVISIONS		320 Amp Combination Meter Socket, Overhead Service	
		DRAWN: SDS	DWG. NO. G18A2103
		SCALE: NTS	FIGURE 15
		DATE: 01/06/09	

Figure 15: 320 Amp Combination Meter Socket, Overhead Service

Wire Sizes		
Service Size	Neutral*	Line
320 Amp	2 - 4/0 Cu.	2 - 4/0 Cu.
	2 - 300 AL	2 - 300 AL

* Neutral may be reduced under specific conditions allowed by NEC.

Note:
This application for 120/208v, 3 wire service.

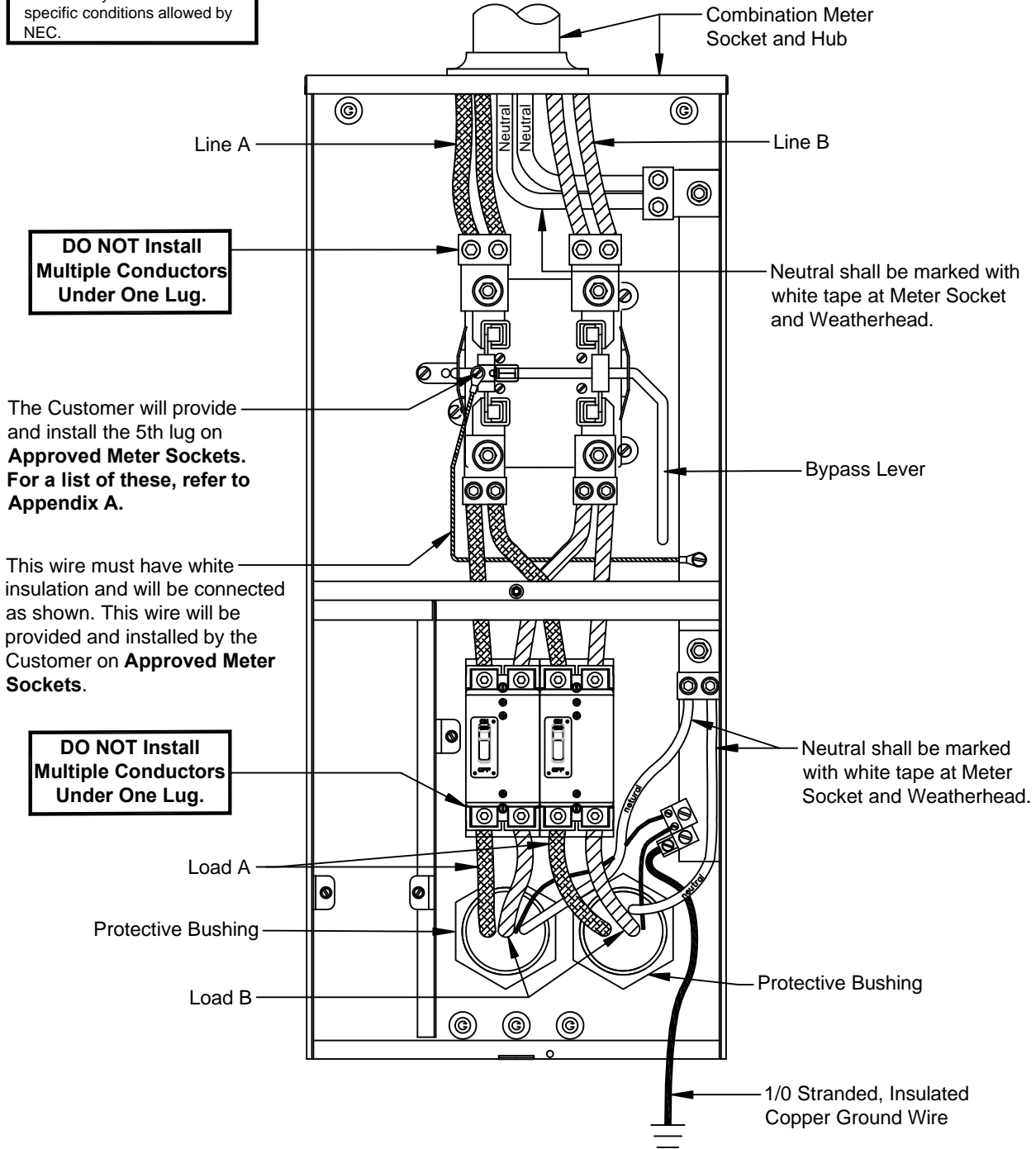

All Equipment Furnished and Installed By Customer Unless Otherwise Noted.

06/11/20 SMS REVISIONS		320 Amp Combination Meter Socket, Network (120/208), Overhead Service	
		DRAWN: KMH	DWG. NO. G18A2103A
		SCALE: NTS	FIGURE 15A
		DATE: 08/05/19	

Figure 15A: 320 Amp Meter Socket, Network (120/208), Overhead Service

Security Light May Be Leased From the Company. Customer will not be allowed to install their light on this pole.

Pole installed and owned by the Company.

This Weatherhead shall be located no more than 3' below the top of the Pole.

The path to the Service Pole shall be clear of trees and building debris and materials.

Service Size	Wire Sizes		Conduit Size	Conduit Type ***
	Neutral**	Line		
100 Amp*	#3 Cu.	#3 Cu.	1 1/4"	Galv. Rigid Steel
	#1 AL.	#1 AL.	1 1/2"	Galv. Rigid Steel
200 Amp	3/0 Cu.	3/0 Cu.	2"	Galv. Rigid Steel
	250 AL.	250 AL.	2 1/2"	Galv. Rigid Steel

* 100 Amp allowed on overhead service only.
 ** Neutral May Be Reduced Under Specific Conditions Allowed By NEC.
 *** Other types of conduit allowed depending on local code.

Company Conductors

A minimum of 24" of wire shall be provided by the Customer. The Neutral shall be marked with white tape. The wire shall be marked or listed as Sunlight Resistant as per NEC 310.10 (D).

Attachment furnished and installed by the Company.

Drip-Loop 10' Clearance (Min.) above Finished Grade.

Two Hole Conduit Strap

Service Drop Minimum Clearances	
12'	Above Sidewalks
16'	Above Residential Driveways
18.5'	Above Public Driveways, Alleys, Roads, and Other Areas Subject to Truck & Construction Traffic.

Meter Loop (Weatherhead, Service Entrance Wire, Conduit, Meter Socket/Breaker Combination, Ground Wire, Ground Rod Clamp, 5/8" x 8' Ground Rod, Etc.) may be purchased from and installed by the Company on Company pole ONLY.

Meter Loop Will be Owned and Maintained by the Customer.

The Meter Pole shall be located within 30' of a Mobile Home/Building; Otherwise see NEC Article 550.32.

This may be a Meter Socket and separate Breaker Enclosure connected by Rigid Conduit.

No Bypass Lever Allowed.

4' To 6' Above Final Grade Level

Service Size	Ground Wire
100 Amp	#6 Cu.
200 Amp	#4 Cu.

Customer supplied and installed Underground Service Feeder.

Ground Wire

Final Grade



5/8" X 8' Copper Clad Steel Ground Rod and Clamp

Note:
 Meter Loop will not be installed on Primary Power Poles.

Ground Wire and Pole Down Ground are bonded together at the Ground Rod.

All Equipment Furnished and Installed By Customer Unless Otherwise Noted.

08/09/19	KMH
07/10/09	SDS
07/15/06	SDS
05/17/05	SDS
01/01/97	AMA
REVISIONS	



100/200 Amp Meter Pole, Underground Feeder	
DRAWN: LU	DWG. NO. G18A2104
SCALE: NTS	FIGURE 16
DATE: 01/01/95	

Figure 16: 100/200 Amp Meter Pole, Underground Feeder

Security Light May Be Leased From The Company. Customer will not be allowed to install their light on this pole.

Pole installed and owned by the Company.

Weatherhead shall be located no more than 3' below the top of the Pole.

Attachment furnished and installed by the Company.

The path to the Service Pole shall be clear of trees and building debris and materials.

Recommended Height as per Table to right and below.

Customer Connectors

Attachment furnished and installed by the Company.

A minimum of 24" of wire shall be provided by the Customer. The Neutral shall be marked with white tape. The wire shall be marked or listed as Sunlight Resistant as per NEC 310.10 (D).

Drip-Loop 10' Clearance (Min.) above Finished Grade.

Company Conductors

A minimum of 24" of wire shall be provided by the Customer. The Neutral shall be marked with white tape. The wire shall be marked or listed as Sunlight Resistant as per NEC 310.10 (D).

Drip-Loop 10' Clearance (Min.) above Finished Grade.

Meter Loop Will be Owned and Maintained by the Customer.

Service Drop Minimum Clearances	
12'	Above Sidewalks
16'	Above Residential Driveways
18.5'	Above Public Driveways, Alleys, Roads, and Other Areas Subject to Truck & Construction Traffic.

Service Size	Wire Sizes		Conduit Size	Conduit Type ***
	Neutral**	Line		
100 Amp*	#3 Cu.	#3 Cu.	1 1/4"	Galv. Rigid Steel
	#1 AL.	#1 AL.	1 1/2"	Galv. Rigid Steel
200 Amp	3/0 Cu.	3/0 Cu.	2"	Galv. Rigid Steel
	250 AL.	250 AL.	2 1/2"	Galv. Rigid Steel

* 100 Amp allowed on overhead service only.
 ** Neutral May Be Reduced Under Specific Conditions Allowed By NEC.
 *** Other types of conduit allowed depending on local code.

This may be a Meter Socket and separate Breaker Enclosure connected by Rigid Conduit.

No Bypass Lever Allowed.

Service Size	Ground Wire
100 Amp	#6 Cu.
200 Amp	#4 Cu.

4' To 6' Above Final Grade Level

Ground Wire

Final Grade

5/8" X 8' Copper Clad Steel Ground Rod and Clamp

Ground Wire and Pole Down Ground are bonded together at the Ground Rod.

Note: Meter Loop will not be installed on Primary Power Poles.

All Equipment Furnished and Installed By Customer Unless Otherwise Noted.

08/09/19	KMH
07/10/09	SDS
07/15/06	SDS
05/17/05	SDS
01/01/97	AMA
REVISIONS	



100/200 Amp Meter Pole, Overhead Feeder	
DRAWN: LU	DWG. NO. G18A2105
SCALE: NTS	FIGURE 17
DATE: 01/01/95	

Figure 17: 100/200 Amp Meter Pole, Overhead Feeder

Security Light May Be Leased From The Company.
Customer will not be allowed to install their light on this pole.

Pole installed and owned by the Company.

Attachment furnished and installed by the Company.

Weatherhead shall be located no more than 3' below the top of the Pole.

Note:
Meter Loop will not be installed on Primary Power Poles.

The path to the Service Pole shall be clear of trees and building debris and materials.

Company conductors

A minimum of 24" of wire shall be provided by the Customer. The Neutral shall be marked with white tape. The wire shall be marked or listed as Sunlight Resistant as per NEC 310.10 (D).

Drip-Loop 10' Clearance (Min.) above Finished Grade.

Service Size	Wire Sizes		Conduit Size	Conduit Type **
	Neutral*	Line		
320 Amp	2-4/0 Cu.	2-4/0 Cu.	3"	Galv. Rigid Steel
	2-300 AL.	2-300 AL.	4"	Galv. Rigid Steel

* Neutral May Be Reduced Under Specific Conditions Allowed By NEC.
** Other types of conduit allowed depending on local code.

Service Drop Minimum Clearances	
12'	Above Sidewalks
16'	Above Residential Driveways
18.5'	Above Public Driveways, Alleys, Roads, and Other Areas Subject to Truck & Construction Traffic.

Two Hole Conduit Strap

Meter Loop, Meter Socket and Customer's Conduit Will Be Owned And Maintained By The Customer.

Customer's Conduit Will Be Owned And Maintained By The Customer.

Customer supplied and installed Underground Service Feeder. This service feeder will be enclosed in either schedule 80 electrical grade PVC or Rigid Galvanized Steel.

4' To 6' above Final Grade Level

1/0 Copper Ground Wire, This can be insulated and stranded.

30" Recommended Ditch Depth.

5/8" X 8' Copper Clad Steel Ground Rod and Clamp

Ground Wire and Pole Down Ground are bonded together at the Ground Rod.

All Equipment Furnished and Installed By Customer Unless Otherwise Noted.

07/31/20	TDK
08/09/19	KMH
07/10/09	SDS
07/15/06	SDS
05/17/05	SDS
01/01/97	AMA
REVISIONS	



320 Amp Meter Pole, Underground Feeder	
DRAWN: LU	DWG. NO. G18A2106
SCALE: NTS	FIGURE 18
DATE: 01/01/95	

Figure 18: 320 Amp Meter Pole, Underground Feeder

Security Light May Be Leased From The Company. Customer will not be allowed to install their light on this pole.

Pole installed and owned by the Company.

Weatherhead shall be located no more than 3' below the top of the Pole.

Attachment furnished and installed by company.

The path to the Service Pole shall be clear of trees and building debris and materials.

Recommended height as per table to right.

Customer conductors (only one set shown for clarity.)

Attachment furnished by company.

Company conductors

A minimum of 24" of wire shall be provided by the Customer. The Neutral shall be marked with white tape. The wire shall be marked or listed as Sunlight Resistant as per NEC 310.10 (D).

A minimum of 24" of wire shall be provided by the Customer. The Neutral shall be marked with white tape. The wire shall be marked or listed as Sunlight Resistant as per NEC 310.10 (D).

Drip-Loop 10' Clearance (Min.) above Finished Grade.

Drip-Loop 10' Clearance (Min.) above Finished Grade.

Note:
Meter Loop will not be installed on Primary Power Poles.

Customer's Conduit

Customer's Conduit

Service Drop Minimum Clearances

12'	Above Sidewalks
16'	Above Residential Driveways
18.5'	Above Public Driveways, Alleys, Roads, and Other Areas Subject to Truck & Construction Traffic.

Service Size	Wire Sizes		Conduit Size	Conduit Type **
	Neutral*	Line		
320 Amp	2-4/0 Cu.	2-4/0 Cu.	3"	Galv. Rigid Steel
	2-300 AL.	2-300 AL.	4"	Galv. Rigid Steel

* Neutral May Be Reduced Under Specific Conditions Allowed By NEC.
** Other types of conduit allowed depending on local code.

Meter Loop, Meter Socket and Customer's Conduit Will Be Owned And Maintained By The Customer.

4' To 6' Above Final Grade Level

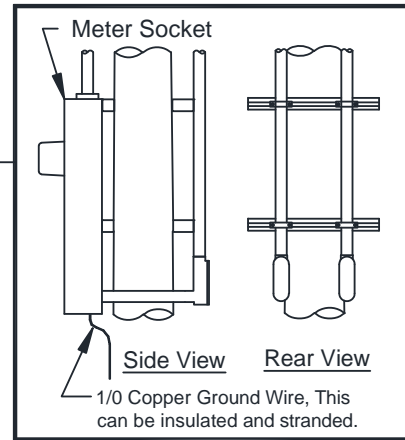

1/0 Copper Ground Wire, This can be insulated and stranded.

5/8" X 8' Copper Clad Steel Ground Rod and Clamp

Ground Wire and Pole Down Ground are bonded together at the Ground Rod.

All Equipment Furnished and Installed By Customer Unless Otherwise Noted.

07/31/20 TDK	REVISIONS
08/05/19 KMH	
07/15/09 SDS	
07/15/06 SDS	
05/15/05 SDS	



320 Amp Meter Pole, Overhead Feeder	
DRAWN: LU	DWG. NO. G18A2107
SCALE: NTS	FIGURE 19
DATE: 07/01/97	

Figure 19: 320 Amp Meter Pole, Overhead Feeder

6.3 400 AMP TO 800 AMP CT METERING, SINGLE PHASE OVERHEAD SERVICE

A. General Notes:

1. This arrangement may be utilized for services equal and above 400 amps and less than or equal to 800 amps.
2. The disconnection method may be composed of multiple disconnects to make up the full 800 amp capacity of the service as long as there are not more than 6. If one disconnect is used and it is greater than 400 amps, it may be located on the interior of the building unless the authority having jurisdiction dictates otherwise. Disconnects of 400 amps and below will be located on the exterior of the building.

Please note that in all cases, the disconnects making up this service will be at the same location.

3. Service drop and meter furnished and installed by the Company.
4. Current transformers (CT) furnished by the Company and may be issued to Customer for installation or installed by Company employees.
5. Meter socket shall be purchased from the Company and installed by Customer.
6. One inch (1") conduit and weatherhead furnished and installed by Customer.
7. Metering control cable furnished and installed by the Company.
8. The meter socket should be "readily accessible" (see definitions). The Company requires a level and unobstructed work space of 78 inches tall, 18 inches on either side, and 48 inches in front of the meter socket. Prior approval is required for placement of the meter socket in alleyways or areas where it may be subjected to damage.
- 9. The length of service drop over the roof shall not exceed four (4) feet.**

B. Mounting:

1. Meter socket, ground wire, and conduit shall be surface mounted and securely fastened to the structure. The meter socket shall be installed in a level and plumb position. **Flush mounted or recessed metering equipment and service riser conduit embedded in a wall will not be permitted.**
2. Where the exterior wall is other than brick or concrete blocks, a supporting frame shall be installed behind the exterior wall to provide a solid mounting surface for the meter socket.
3. Meter sockets, metering cabinets, and conduit straps shall be installed with the following:
 - a. Lead anchors or double helix concrete screws shall be used with brick or solid concrete surfaces.
 - b. Toggle bolts shall be used with other masonry siding.
 - c. Wood screws shall be used with solid wood surfaces.
 - d. All mounting hardware shall be minimum #12(1/4") corrosion resistant screws
 - e. A minimum of 4 fasteners shall be used to install any socket or cabinet unless specifically stated otherwise.
4. An intersystem bonding termination bar shall be installed to facilitate the connection of other utility's ground to a common ground. The location of this device shall be located directly below the meter socket or meter combination socket.
 - a. **See Appendix A for list of approved intersystem bonding termination bars.**

5. Wire not enclosed in conduit shall be a minimum of 36 inches away from any window or door opening.

C. Connections:

All connections shall be made by the Company.

D. Conductor Marking:

All neutral conductors shall be clearly marked with white tape at the point of delivery.

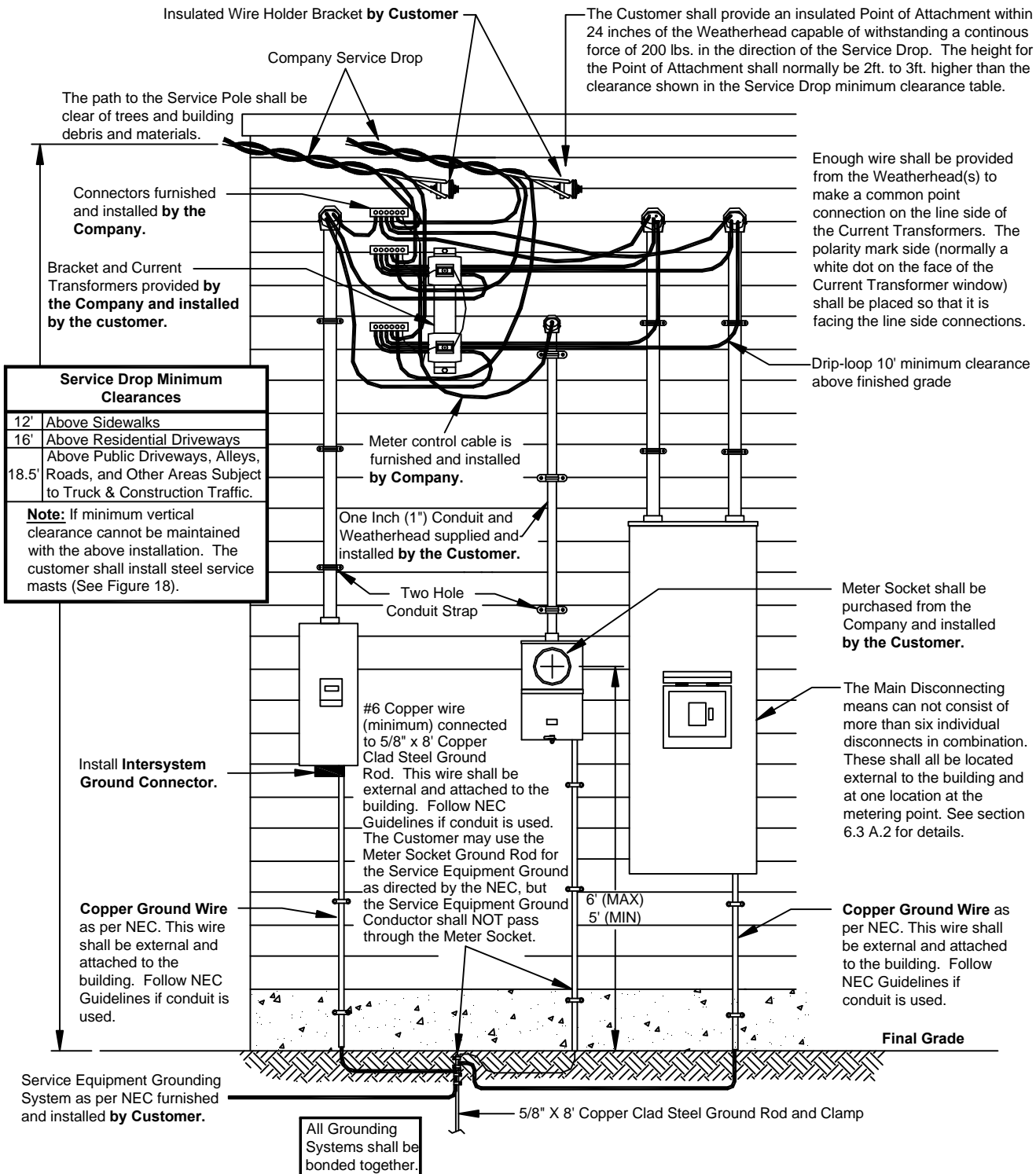

All Equipment Furnished and Installed by Customer Unless Otherwise Noted.

08/12/19	KMH
07/13/07	SDS
05/02/07	SDS
05/15/06	SDS
REVISIONS	



400 Amp to 800 Amp Current Transformer Overhead Service	
DRAWN: LU	DWG. NO. G18A2108
SCALE: NTS	FIGURE 20
DATE:01/01/96	

Figure 20: 400 Amp to 800 Amp CT Metering, Overhead Service

Enough wire shall be provided from the Weatherhead(s) to make a common point connection on the line side of the Current Transformers. The polarity mark side (normally a white dot on the face of the Current Transformer window) shall be placed so that it is facing the line side connections.

Company Service Drop

Insulated Wire Holder Bracket by Customer

Service Mast is to be Rigid Steel. The minimum conduit size is 2"

Bracket and Current Transformers provided by the Company, installed by Customer.

Each Conduit is attached to Unistrut by using Conduit Clamp.

The path to the Service Pole shall be clear of trees and building debris and materials

12" (MAX)

30" (MIN)
40" (MAX)
to attachment point

12" (MAX)

One Inch (1") Conduit and Weatherhead supplied and installed by the Customer.

Meter Control Cable furnished and installed by Company.

Drip Loop will be a Minimum of 10' Above Finished Grade

Two Hole Conduit Strap

Service Drop Minimum Clearances	
12'	Above Ground
16'	Above Residential Driveways
18.5'	Above Public Driveways, Alleys, Roads, and Other Areas Subject to Truck & Construction Traffic.

The Main Disconnecting means can not consist of more than six individual disconnects in combination. These shall all be located external to the building and at one location at the metering point. See Section 6.3 A.2 for details.

Install Intersystem Ground Connector.

Meter Socket shall be purchased from the Company and installed by the Customer

Copper Ground Wire as per NEC. This wire shall be external and attached to the building. Follow NEC Guidelines if Conduit is used.

#6 Copper Wire shall be external and attached to the building. Follow NEC Guidelines if Conduit is used. Customer may use the Meter Socket Ground Rod for the Service Equipment Ground as directed by the NEC, but the Service Equipment Ground Conductor shall not pass through the Meter Socket.

6" (MAX)
5" (MIN)

Final Grade

Service Equipment Grounding System as per NEC furnished and installed by Customer

#6 Copper Ground Wire

5/8" X 8' Copper Clad Steel Ground Rod and Clamp

All Grounding Systems shall be bonded together.

All Equipment Furnished and Installed By Customer Unless Otherwise Noted

07/09/19	KMH
07/13/09	SDS
07-15-06	SDS
REVISIONS	



400 Amp to 800 Amp CT Metering with Service Mast	
DRAWN: LU	DWG. NO. G18A2109
SCALE: NTS	FIGURE 21
DATE:01/01/96	

Figure 21: 400 Amp to 800 Amp CT Metering, with Service Mast

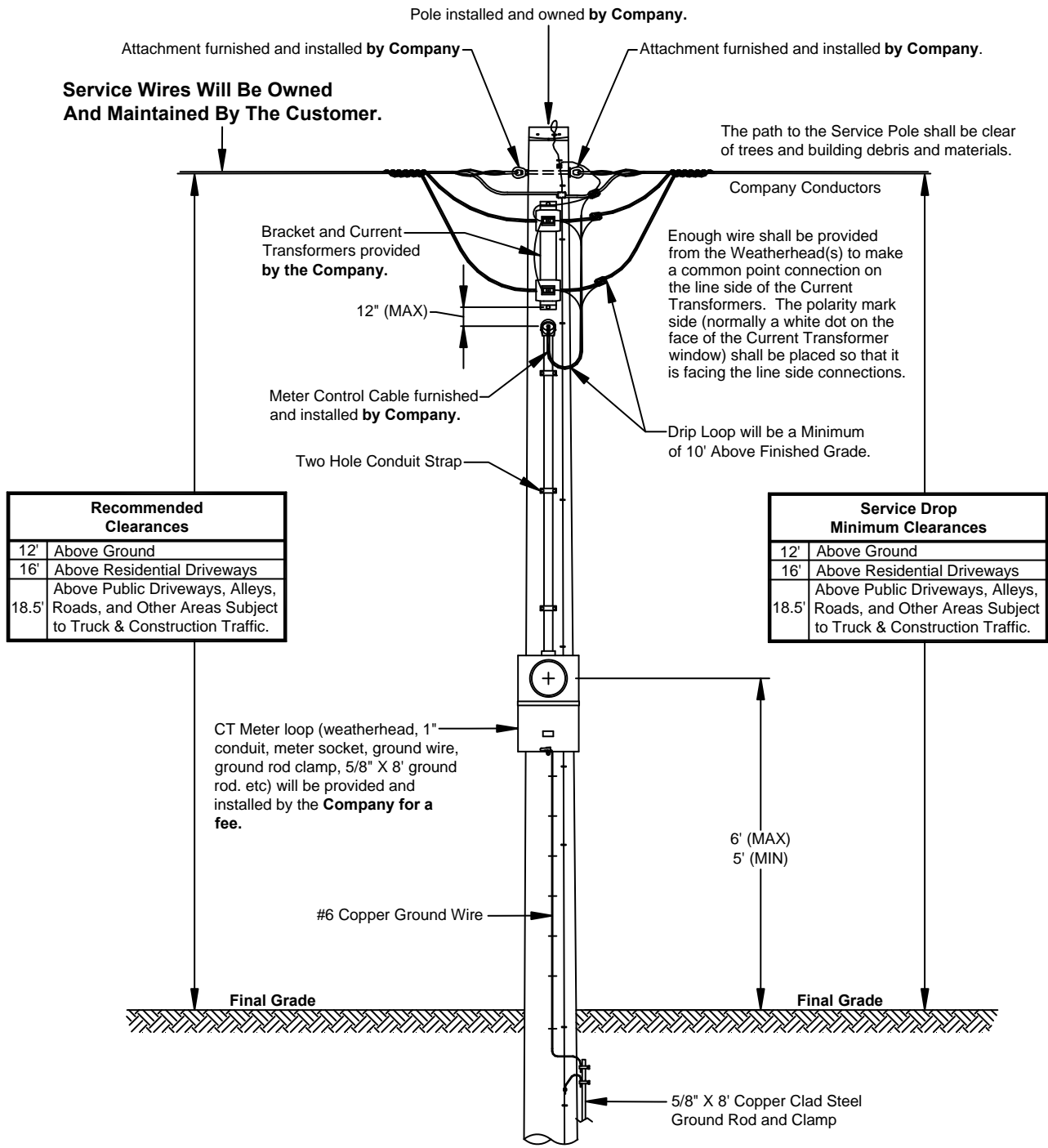

Meter Loop will not be installed on Primary Power Poles.

01/29/20 SMS 08/09/19 KMH 07-15-06 SDS REVISIONS		400 Amp to 800 Amp CT Metering Pole	
		DRAWN: LU	DWG. NO. G18A2110
		SCALE: NTS	FIGURE 22
		DATE:01/01/96	

Figure 22: 400 Amp to 800 Amp CT Metering, Pole



Meter Loop will not be installed on Primary Power Poles.

07/09/19 KMH REVISIONS		400 Amp to 800 Amp CT Metering Pole, Underground Feeder	
		DRAWN: LU	DWG. NO. G18A2111
		SCALE: NTS	FIGURE 23
		DATE:07/15/06	

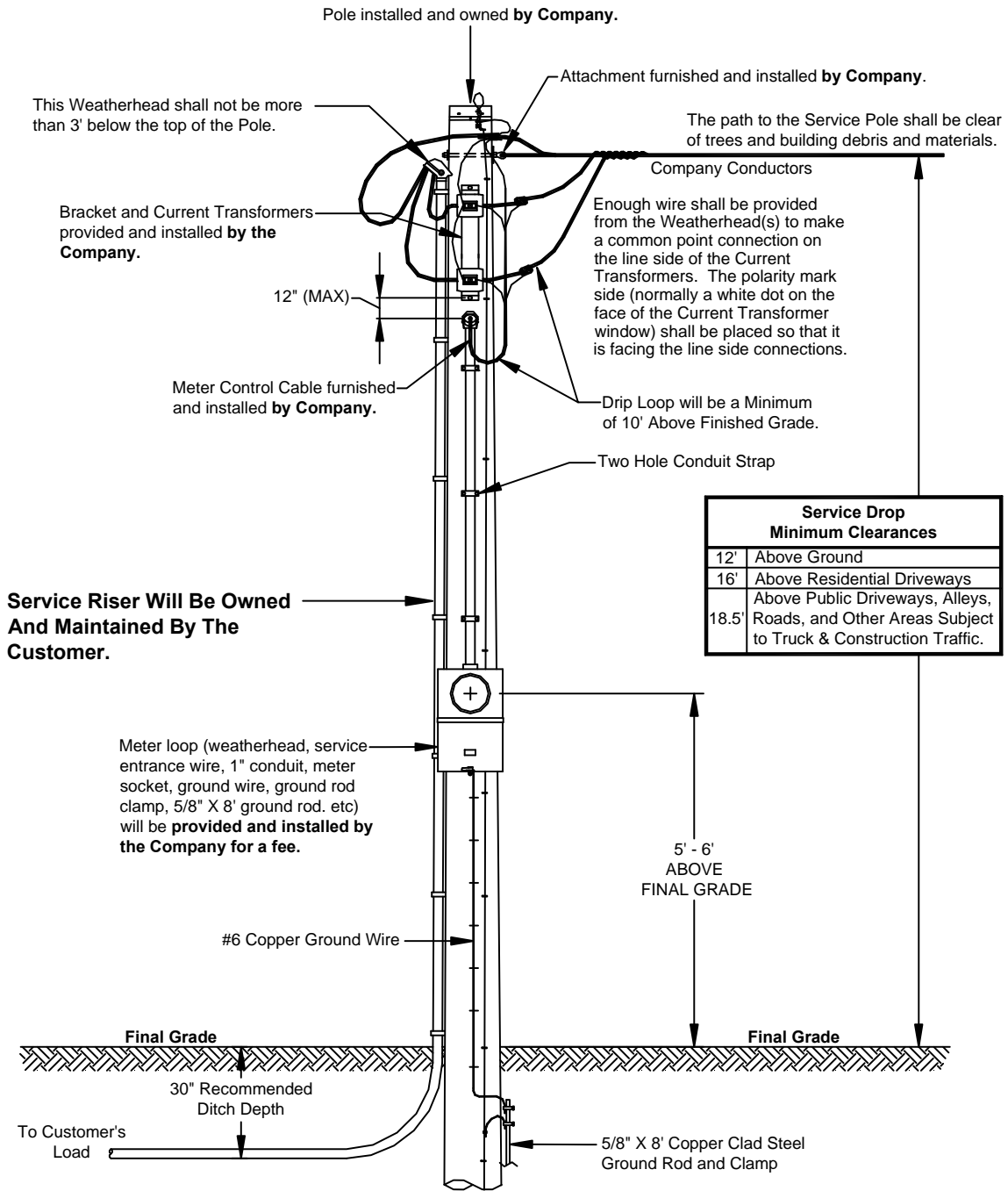
Figure 23: 400 Amp to 800 Amp CT Metering, Pole, Underground Feeder

6.4 MULTIPLE METERS, SINGLE PHASE OVERHEAD SERVICE

A. General Notes:

1. If more than six meters are required, consult the Company for approval of equipment prior to purchase.
2. Service entrance conductors, 5/8" x 8' copper clad steel ground rod, ground rod clamp, ground wire, conduit, conduit straps, weatherhead, lock nuts, bushings, meter socket assembly, meter socket assembly hub, service drop attachment device, and miscellaneous mounting hardware furnished and installed by the Customer.
3. Meters, service connectors, and service drop furnished and installed by Company.
4. The meter socket assembly should be "readily accessible" (see definitions). The Company requires a level and unobstructed work space of 78 inches tall, 18 inches on either side, and 48 inches in front of the meter socket assembly. Prior approval is required for placement of the meter socket assembly in alleyways or areas where it may be subjected to damage.
5. If the Company is required to attach the service drop directly to the Customer's meter loop conduit, the Customer shall install a steel service mast.
6. The meter sockets shall meet the following specifications:
 - a. The latest revision of U.L. 414 and ANSI C12.7 Standards.
 - b. Must be U.L. listed.
 - c. Must have grounding connector for triplex.
 - d. Lug size – 2/0 minimum.
 - e. On 120/208v services, the customer must provide the meter socket with 5th lug installed in the 9 o'clock position.
 - f. **See Appendix A for list of approved meter sockets.**

B. Mounting:

1. Meter socket, ground wire, and conduit shall be surface mounted and securely fastened to the structure. The meter socket shall be installed in a level and plumb position. **Flush mounted or recessed metering equipment and service riser conduit embedded in a wall will not be permitted.**
2. Where the exterior wall is other than brick or concrete blocks, a supporting frame shall be installed behind the exterior wall to provide a solid mounting surface for the meter socket.
3. Meter sockets, metering cabinets, and conduit straps shall be installed with the following:
 - a. Lead anchors or double helix concrete screws shall be used with brick or solid concrete surfaces.
 - b. Toggle bolts shall be used with other masonry siding.
 - c. Wood screws shall be used with solid wood surfaces.
 - d. All mounting hardware shall be minimum #12(1/4") corrosion resistant screws.
 - e. A minimum of 4 fasteners shall be used to install any socket or cabinet unless specifically stated otherwise.

4. An intersystem bonding termination bar shall be installed to facilitate the connection of other utility's ground to a common ground. The location of this device shall be located directly below the meter socket or meter combination socket.

a. See Appendix A for list of approved intersystem bonding termination bars.

5. Wire not enclosed in conduit shall be a minimum of 36 inches away from any window or door opening.

C. Connections:

1. The Customer is responsible for termination of the incoming wiring if the wire terminates in a main breaker or fuse holder. The Company will terminate the incoming wire if it terminates on bus bar terminals. The main breaker will be removed when the service wire is being pulled by the Company.
2. Do not score line or load wire when removing insulation.
3. The Customer shall use wire brush or sandpaper to clean all conductors, apply a non-grit type inhibitor and tighten to manufacturer's specifications.

D. Meter Socket Marking:

1. **Before the meters are installed, each socket position and corresponding building unit, i.e. apt number or letter, Suite number or letter, tenant number or letter, or physical address served shall be accurately, clearly, and permanently labeled with an engraved plaque. See the figures for proper location. These shall be screwed, bolted or riveted to the equipment. If the equipment is marked incorrectly, the customer shall be responsible for all costs incurred by LU for correcting the meter socket identification. Please note that marker ink or adhesive labels are examples of non-permanent labeling.**
2. **Letters or numbers on the engraved plaque shall be a minimum of one (1) inch in height of contrasting color, i.e., black and white, red and green, orange and blue, etc.**

E. Conductor Marking:

All neutral conductors shall be clearly marked with white tape at the point of delivery and at the meter socket assembly.

SINGLE PHASE COMMERCIAL & INDUSTRIAL

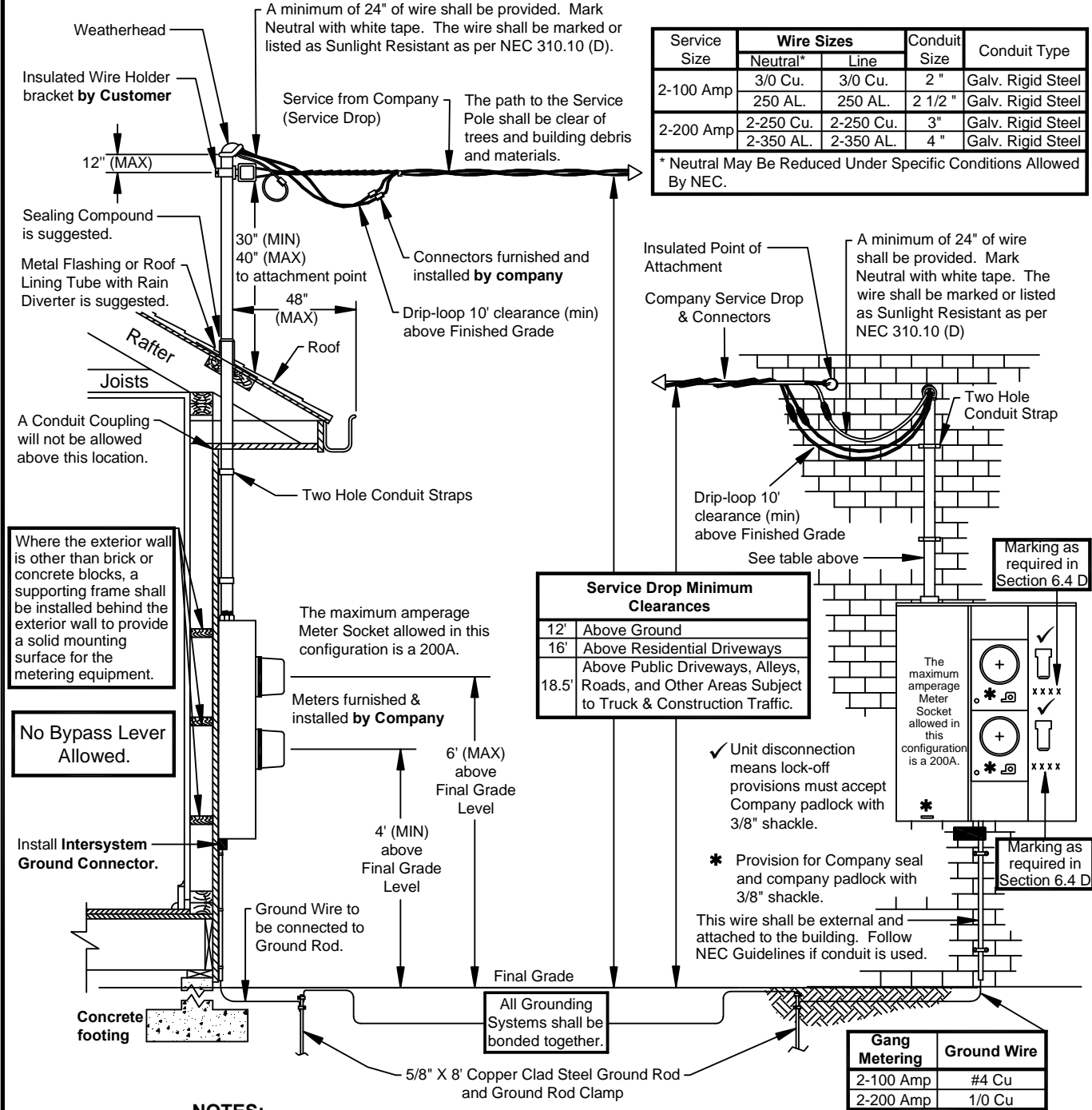

Service Size	Wire Sizes		Conduit Size	Conduit Type
	Neutral*	Line		
2-100 Amp	3/0 Cu.	3/0 Cu.	2"	Galv. Rigid Steel
	250 AL.	250 AL.	2 1/2"	Galv. Rigid Steel
2-200 Amp	2-250 Cu.	2-250 Cu.	3"	Galv. Rigid Steel
	2-350 AL.	2-350 AL.	4"	Galv. Rigid Steel

* Neutral May Be Reduced Under Specific Conditions Allowed By NEC.

Service Drop Minimum Clearances	
12'	Above Ground
16'	Above Residential Driveways
18.5'	Above Public Driveways, Alleys, Roads, and Other Areas Subject to Truck & Construction Traffic.

Gang Metering	Ground Wire
2-100 Amp	#4 Cu
2-200 Amp	1/0 Cu

NOTES:

1. If minimum vertical clearance cannot be maintained with the installation of an attachment bolt as shown above, the Customer shall install a Steel Service Mast as shown directly above left.
2. Connections between Service Drop and Service Entrance Conductors shall be made by Company personnel below Weatherhead, forming a Drip Loop.
3. Other Types of conduit may be allowed depending on Local Code Requirements. These may include EMT, Electrical Grade (schedule 80) PVC, and Rigid Aluminum. **However, the Service Drop shall not be attached to any of these.**

All Equipment Furnished and Installed By Customer Unless Otherwise Noted.

01/29/20 SMS	08/09/19 KMH	07/15/06 SDS	05/17/05 SDS	REVISIONS		Wiring of two Meters, Overhead Service	
						DRAWN: LU DWG. NO. G18A2112 SCALE: NTS DATE: 01/01/95 FIGURE 24	

Figure 24: Wiring of Two Meters, Overhead Service

A minimum of 24" of wire shall be provided. Mark Neutral with white tape. The wire shall be marked or listed as Sunlight Resistant as per NEC 310.10 (D).

The path to the Service Pole shall be clear of trees and building debris and materials.

Company Service Drop & Connectors

Drip-loop 10' clearance (min) above Finished Grade

Insulated Point of Attachment

The number, type, and size of conduits will vary with each installation. Contact Liberty Utilities for more information.

Service Drop Minimum Clearances	
12'	Above Ground
16'	Above Residential Driveways
18.5'	Above Public Driveways, Alleys, Roads, and Other Areas Subject to Truck & Construction Traffic.

Number of conduits may vary depending on service requirements.

Two Hole Conduit Strap

Where the exterior wall is other than brick or concrete blocks, a supporting frame shall be installed behind the exterior wall to provide a solid mounting surface for the metering equipment.

* Provision for Company seal and company padlock with 3/8" shackle.

☒☒☒ Marking as required in Section 6.4.D.

✓ Unit disconnection means lock-off provisions must accept Company padlock with 3/8" shackle.

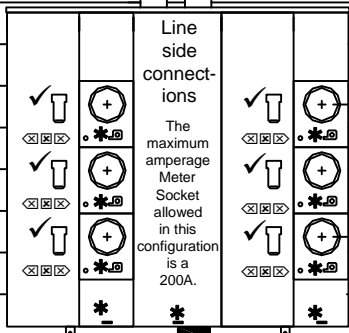

No Bypass Lever Allowed.

6' (MAX) above Final Grade

Install a #6 copper wire (Minimum) from the same connection point as the main Copper Ground Wire connection through the Intersystem Ground Connector.

Copper Ground Wire as per NEC. This wire shall be external and attached to the building. Follow NEC Guidelines if conduit is used.

3' (MIN) above Final Grade

A minimum of one 5/8" X 8" Copper Clad Steel Ground Rod shall be provided by Customer. However, more than one Ground Rod may be needed. Consult NEC for requirements.

All Grounding Systems shall be bonded together.

Notes:

1. If minimum vertical clearance cannot be maintained with the installation of an attachment point as shown above, contact the Company for requirements.
2. Connections between Service Drop and Service Entrance Conductors shall be made by Company personnel below Weatherhead, forming a Drip Loop.
3. Service Entrance Conductors shall be sized as per NEC

If more than 6 meters are required, please contact the Company for configuration. As a minimum, Liberty Utilities will require the riser diagram and cut sheets as proposed by the Electrical Engineer.

All Equipment Furnished and Installed By Customer Unless Otherwise Noted.

08/029/19	KMH
05/13/09	SDS
07/15/06	SDS
05/17/05	SDS
REVISIONS	



Three to Six Meters, Overhead Service	
DRAWN: LU	DWG. NO. G18A2113
SCALE: NTS	FIGURE 25
DATE:01/01/95	

Figure 25: Three to Six Meters, Overhead Service

6.5 100/200 AMP(208Y/120V or 240Δ /120V only) THREE PHASE OVERHEAD SERVICE

A. General Notes:

1. Service entrance conductors, 5/8" x 8' copper clad steel ground rod, ground rod clamp, ground wire, conduit, conduit straps, weatherhead, lock nuts, bushings, service drop attachment device, meter socket, main disconnect, meter socket hub, and miscellaneous mounting hardware furnished and installed by the Customer.
2. Meter, service connectors, and service drop furnished and installed by Company.
3. The meter socket should be "readily accessible" (see definitions). The Company requires a level and unobstructed work space of 78 inches tall, 18 inches on either side, and 48 inches in front of the meter socket. Prior approval is required for placement of the meter socket in alleyways or areas where it may be subjected to damage.
4. Installation requiring a steel service mast shall be installed by the Customer as specified in Figure 27.
5. **The 200 amp meter socket shall be purchased from the Company and installed by the Customer.**

B. Mounting:

1. Meter socket, ground wire, and conduit shall be surface mounted and securely fastened to the structure. The meter socket shall be installed in a level and plumb position. **Flush mounted or recessed metering equipment and service riser conduit embedded in a wall will not be permitted.**
2. Where the exterior wall is other than brick or concrete blocks, a supporting frame shall be installed behind the exterior wall to provide a solid mounting surface for the meter socket.
3. Meter sockets, metering cabinets, and conduit straps shall be installed with the following:
 - a. Lead anchors or double helix concrete screws shall be used with brick or solid concrete surfaces.
 - b. Toggle bolts shall be used with other masonry siding.
 - c. Wood screws shall be used with solid wood surfaces.
 - d. All mounting hardware shall be minimum #12(1/4") corrosion resistant screws.
 - e. A minimum of 4 fasteners shall be used to install any socket or cabinet unless specifically stated otherwise.
4. An intersystem bonding termination bar shall be installed to facilitate the connection of other utility's ground to a common ground. The location of this device shall be located directly below the meter socket or meter combination socket.
a. See Appendix A for list of approved intersystem bonding termination bars.
5. Wire not enclosed in conduit shall be a minimum of 36 inches away from any window or door opening.

C. Connections:

1. Do not score line or load wire when removing insulation
2. The Customer shall use wire brush or sandpaper to clean all conductors, apply a no-grit type inhibitor and tighten to manufacturer's specifications.

D. Conductor marking

1. All neutral conductors shall be clearly marked with white tape at the point of delivery and at the meter socket.
2. The power leg of each 240/120 volt, three-phase, four-wire delta service shall be clearly marked with orange tape at the point of delivery and at the meter location (refer to Figure 29).

E. Phase Rotation

1. On three-phase installations to insure proper equipment operation, the Customer is responsible for verifying phase rotation at the time of service connection.

Minimum Attachment Height shall be 12' above final grade. The Customer shall provide an insulated Point of Attachment within 24" of the Weatherhead which is capable of withstanding a continuous force of 200 lbs. in the direction of pull of the Service Drop.

A minimum of 24" of wire shall be provided by the Customer. The Neutral shall be marked with white tape. The wire shall be marked or listed as Sunlight Resistant as per NEC 310.10 (D).

The path to the Service Pole shall be clear of trees and building debris and materials.

Service Drop Minimum Clearances	
12'	Above Sidewalks
16'	Above Residential Driveways
18.5'	Above Public Driveways, Alleys, Roads, and Other Areas Subject to Truck & Construction Traffic.

Company Service Drop and Connectors

Meter furnished and installed by Company.
Install Intersystem Ground Connector.

Drip Loop will be a minimum of 10' above Finished Grade.

Two Hole Conduit Strap

Meter Socket See Note 4 Below
Main Disconnect See Note 5 Below

This wire shall be external and attached to the building. Follow NEC guidelines if Conduit is used. 4' to 6' Above Final Grade

Service Size	Ground Wire
100 Amp	#6 Cu.
200 Amp	#4 Cu.

Ground Rod Clamp

All Grounding Systems shall be bonded together.

5/8" X 8' Copper Clad Steel Ground Rod installed external to Building.

Service Size	Wire Sizes		Conduit Size	Conduit Type***
	Neutral**	Line		
100 Amp*	#1 Cu.	#1 Cu.	1 1/2"	Galv. Rigid Steel
	2/0 AL.	2/0 AL.	2"	Galv. Rigid Steel
200 Amp	250 Cu.	250 Cu.	2 1/2"	Galv. Rigid Steel
	350 AL.	350 AL.	3"	Galv. Rigid Steel

* 100 Amp allowed on overhead service only.
** Neutral May Be Reduced Under Specific conditions Allowed By NEC (see section 2.4.5).
*** Other types of conduit allowed depending on local code.

This ONLY applies to 208Y/120V or 240 DELTA/120V services.

Ground Rod and Wire MUST be Installed and Ground Wire MUST be attached to the structure before Service will be Connected.

Notes:

1. If minimum vertical clearance cannot be maintained with the installation of an attachment as shown above, the Customer shall install a rigid steel service mast as shown in Figure 27.
2. Connections between the Service Drop and Service Entrance Conductors shall be made by Company Personnel below the Weatherhead, forming a Drip Loop.
3. Other types of conduit may be allowed depending on Local Code Requirements. These may include EMT, Electrical Grade PVC, and Rigid Aluminum. However, the Service Drop shall not be attached to any of these.
4. The 200 amp meter socket shall be purchased from the Company.
5. The disconnect shall be located on the exterior of the structure. It shall not be closer than 1" nor farther than 1' from the meter socket.

All Equipment Furnished and Installed By Customer Unless Otherwise Noted.

08/27/19 KMH 07/10/09 SDS 07/15/06 SDS 05/17/05 SDS 01/01/97 AWA REVISIONS		100/200 Amp Overhead Service	
		DRAWN: LU	DWG. NO. G18A2114
		SCALE: NTS	FIGURE 26
		DATE: 01/01/95	

Figure 26: 100/200 Amp Overhead Service

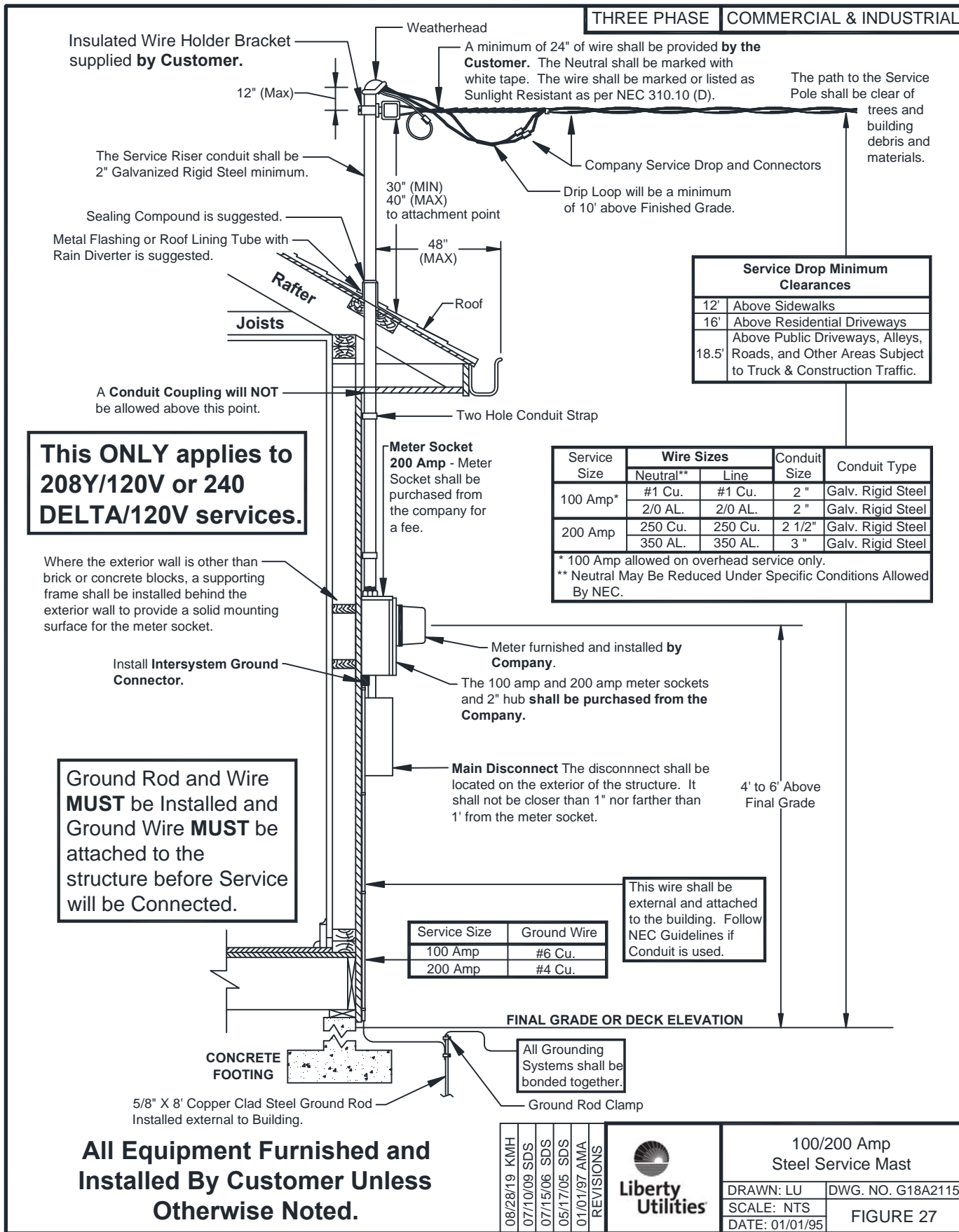
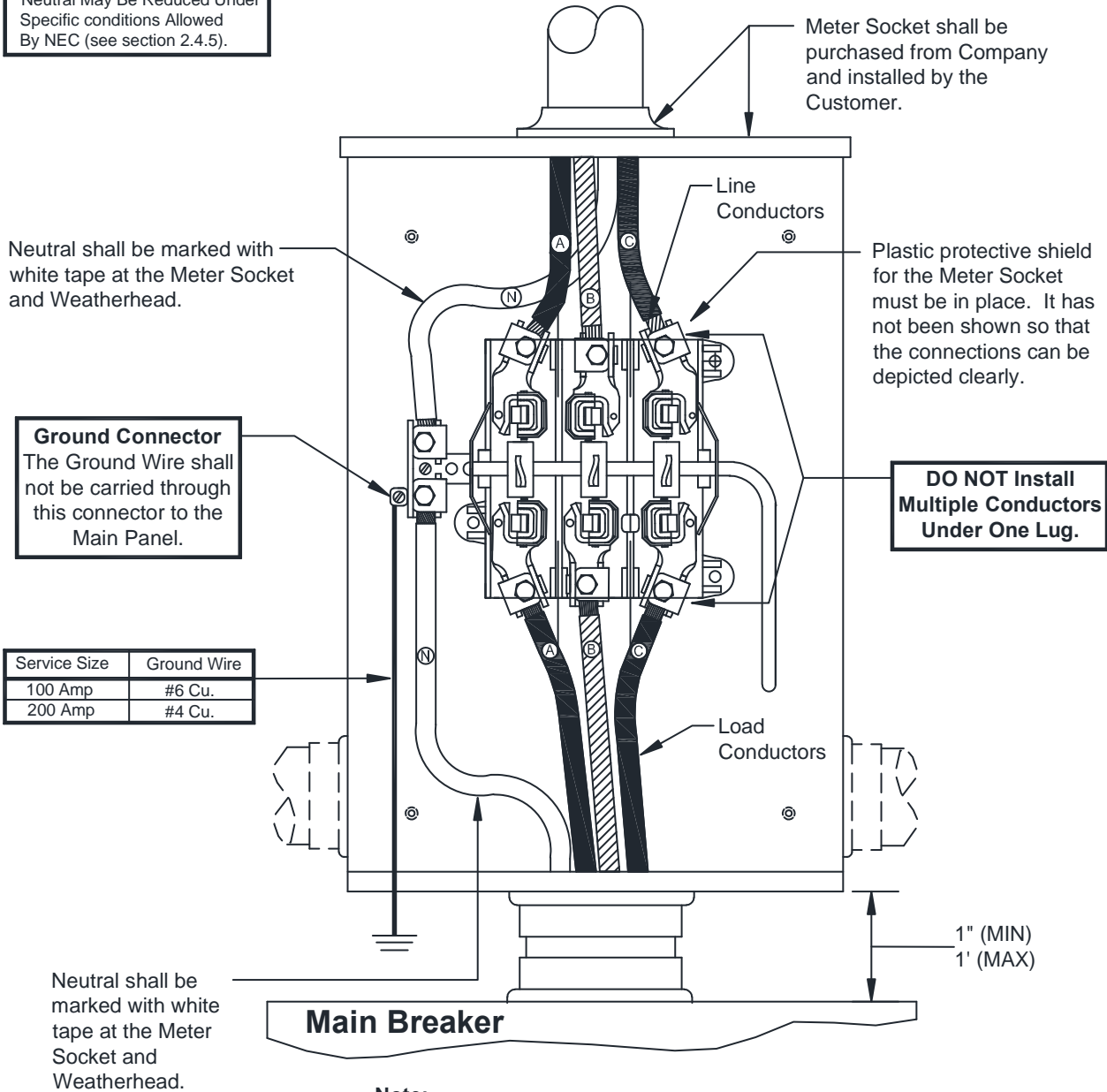

Figure 27: 100/200 Amp Steel Service Mast

Service Size	Wire Sizes	
	Neutral*	Line
100 Amp	#1 Cu.	#1 Cu.
	2/0 AL.	2/0 AL.
200 Amp	250 Cu.	250 Cu.
	350 AL.	350 AL.

* Neutral May Be Reduced Under Specific conditions Allowed By NEC (see section 2.4.5).

Note:
This service not available for 480Y/277V.



Service Size	Ground Wire
100 Amp	#6 Cu.
200 Amp	#4 Cu.

Note:
1. On delta installation, B phase position must be the Power (High) Leg (See Figure 29).

All Equipment Furnished and Installed By Customer Unless Otherwise Noted.

01/29/20 SMS 08/09/19 KMH 03/18/10 SDS 07/13/09 SDS 07/15/06 SDS REVISIONS		100/200 Amp Meter Socket, Overhead Service
DRAWN: LU		DWG. NO. G18A2116
SCALE: NTS		FIGURE 28
DATE: 01/01/96		

Figure 28: 100/200 Amp Meter Socket, Overhead Service

Delta Connected Transformer Bank
 This is for Pole Mounted Transformers only and is limited to 200 amp Capacity.

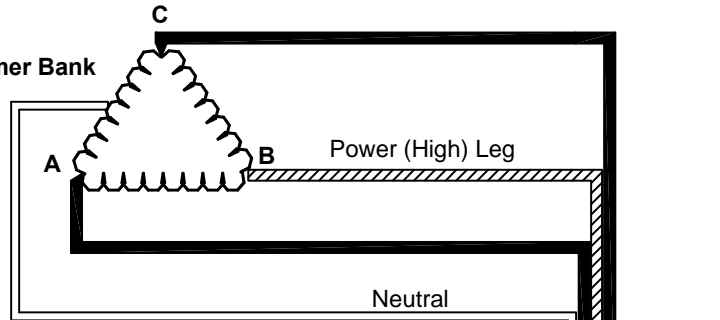

Power (High) Leg MUST be in the center lug for correct meter registration. Mark this phase with orange tape.

NOTE:
 Power (High) Leg must be in the "B" phase in the Customer's Switchboard or Panelboard to comply with NEC 408.3(3)(E).

Also refer to Figure 28

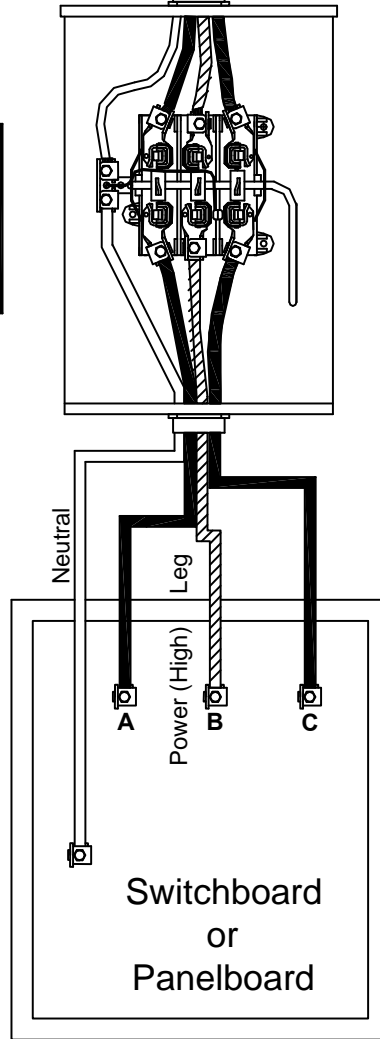

08/16/19 KMH 07/15/06 SDS REVISIONS		Power Leg Connection on Three Phase, Four Wire, Delta Connected Systems	
		DRAWN: LU	DWG. NO. G18A2117
		SCALE: NTS	FIGURE 29
		DATE: 01/01/96	

Figure 29: Power Leg Connection on 3 Phase, 4 Wire Delta Connected Systems

Security Light May Be Leased From the Company. Customer will not be allowed to install their light on this pole.

Pole installed and owned **by the Company**.

This Weatherhead shall be located no more than 3' below the top of the Pole.

The path to the Service Pole shall be clear of trees and building debris and materials.

Service Size	Wire Sizes		Conduit Size	Conduit Type***
	Neutral**	Line		
100 Amp*	#1 Cu.	#1 Cu.	1 1/2" "	Galv. Rigid Steel
	2/0 AL.	2/0 AL.	2" "	Galv. Rigid Steel
200 Amp	250 Cu.	250 Cu.	2 1/2" "	Galv. Rigid Steel
	350 AL.	350 AL.	3" "	Galv. Rigid Steel

* 100 Amp allowed on overhead service only.
 ** Neutral May Be Reduced Under Specific conditions Allowed By NEC (see section 2.4.5).
 *** Other types of conduit allowed depending on local code.

A minimum of 24" of wire shall be provided **by the Customer**. The Neutral shall be marked with white tape. The wire shall be marked or listed as Sunlight Resistant as per NEC 310.10 (D).

Attachment furnished and installed **by the Company**.

Drip-Loop 10' Clearance (Min.) above Finished Grade.

Service Drop Minimum Clearances	
12'	Above Ground
16'	Above Residential Driveways
18.5'	Above Public Driveways, Alleys, Roads, and Other Areas Subject to Truck & Construction Traffic.

Meter Loop Will be Owned and Maintained by the Customer.

200 Amp Meter Socket shall be purchased from the Company and installed **by the Customer**.

Customer Breaker Enclosure

The Customer Breaker Enclosure shall not be closer than 1" nor farther than 1' from the meter socket.

This ONLY applies to 208Y/120V or 240 DELTA/120V services.

4' To 6' Above Final Grade Level

Service Size	Ground Wire
100 Amp	#6 Cu.
200 Amp	#4 Cu.

Customer supplied and installed Underground Service Feeder

FINAL GRADE

Meter Loop will not be installed on Primary Power Poles.

30" Recommended Ditch Depth.

5/8" X 8' Copper Clad Steel Ground Rod and Clamp

Ground Wire and Pole Down Ground are bonded together at the Ground Rod.

All Equipment Furnished and Installed By Customer Unless Otherwise Noted.

08/14/19 KMH 07/15/06 SDS REVISIONS		100/200 Amp Meter Pole, Underground Feeder	
		DRAWN: LU	DWG. NO. G18A2118
		SCALE: NTS	FIGURE 30
		DATE: 01/01/96	

Figure 30: 100/200 Amp Meter Pole, Underground Feeder

6.6 200 AMP TO 1200 AMP CT METERING, THREE PHASE OVERHEAD SERVICE

A. General Notes:

1. This arrangement may be utilized for services 200 amps and above.
2. The disconnection method may be composed of multiple disconnects to make up the full 1200 amp capacity of the service as long as there are not more than 6. If one disconnect is used that it is greater than 400 amps, it may be located on the interior of the building unless the authority having jurisdiction dictates otherwise. Disconnects of 400 amps and below will be located on the exterior of the building. **Please note that in all cases, the disconnects making up this service will be at the same location.**
3. Service drop and meter furnished and installed by the Company.
4. Current transformers (CT) shall be furnished by the Company and installed by the Customer.
5. Meter socket shall be purchased from the Company and installed by Customer.
6. One inch (1") conduit and weatherhead furnished and installed by Customer.
7. Metering control cable furnished and installed by the Company.
8. The meter socket should be "readily accessible" (see definitions). The Company requires a level and unobstructed work space of 78 inches tall, 18 inches on either side, and 48 inches in front of the meter socket. Prior approval is required for placement of the meter socket in alleyways or areas where it may be subjected to damage.
9. **The length of service drop over roof shall not exceed four (4) feet.**

B. Mounting:

1. Meter socket, ground wire, and conduit shall be surface mounted and securely fastened to the structure. The meter socket shall be installed in a level and plumb position. **Flush mounted or recessed metering equipment and service riser conduit embedded in a wall will not be permitted.**
2. Where the exterior wall is other than brick or concrete blocks, a supporting frame shall be installed behind the exterior wall to provide a solid mounting surface for the meter socket.
3. Meter sockets, metering cabinets, and conduit straps shall be installed with the following:
 - a. Lead anchors or double helix concrete screws shall be used with brick or solid concrete surfaces.
 - b. Toggle bolts shall be used with other masonry siding.
 - c. Wood screws shall be used with solid wood surfaces.
 - d. All mounting hardware shall be minimum #12(1/4") corrosion resistant screws.
 - e. A minimum of 4 fasteners shall be used to install any socket or cabinet unless specifically stated otherwise.
4. An intersystem bonding termination bar shall be installed to facilitate the connection of other utility's ground to a common ground. The location of this device shall be located directly below the meter socket or meter combination socket.
 - a. **See Appendix A for list of approved intersystem bonding termination bars.**
5. Wire not enclosed in conduit shall be a minimum of 36 inches away from any window or door opening.

C. Connections:

1. All connections shall be made by the Company.
2. For service situations that require more than four (4) service risers, contact the Company.

D. Conductor marking

All neutral conductors shall be clearly marked with white tape at the point of delivery.

E. Phase Rotation

1. On three-phase installations to insure proper equipment operation, the Customer is responsible for verifying phase rotation at the time of service connection.

The Customer shall provide an insulated Point of Attachment within 24 inches of the Weatherhead capable of withstanding a continuous force of 200 lbs. in the direction of the Service Drop. The height for the Point of Attachment shall normally be 2ft. to 3ft. higher than the clearance shown in the Service Drop minimum clearance table.

The path to the Service Pole shall be clear of trees and building debris and materials.

Connectors furnished and installed by the Company.

Bracket and Current Transformers provided by the Company and installed by the Customer.

Enough wire shall be provided from the Weatherhead(s) to make a common point connection on the line side of the Current Transformers. The polarity mark side (normally a white dot on the face of the Current Transformer window) shall be placed so that it is facing the line side connections.

One Inch (1") Conduit and Weatherhead supplied by the Customer.

Drip-loop 10' minimum clearance above finished grade. For 480Y/277V service, the minimum clearance above Final Grade is 12'. If this clearance cannot be obtained, then the service must be installed underground. See Figure 55.

Meter control cable is furnished and installed by Company.

Meter Socket shall be purchased from the Company and installed by the Customer.

Install Intersystem Ground Connector.

6' (MAX)
5' (MIN)

The Main Disconnecting means can not consist of more than six individual disconnects in combination. These shall all be located external to the building and at one location at the metering point. See section 6.6 A.2 for details.

Copper Ground Wire as per NEC. This wire shall be external and attached to the building. Follow NEC Guidelines if conduit is used.

Copper Ground Wire as per NEC. This wire shall be external and attached to the building. Follow NEC Guidelines if conduit is used.

Final Grade

Final Grade

Service Equipment Grounding System as per NEC furnished and installed by Customer.

5/8" X 8' Copper Clad Steel Ground Rod and Clamp

#6 Copper wire (minimum) connected to 5/8" x 8' Copper Clad Steel Ground Rod. This wire shall be external and attached to the building. Follow NEC Guidelines if conduit is used. The Customer may use the Meter Socket Ground Rod for the Service Equipment Ground as directed by the NEC, but the Service Equipment Ground Conductor shall NOT pass through the Meter Socket.

All Grounding Systems shall be bonded together.

Service Drop Minimum Clearances	
12'	Above Ground
16'	Above Residential Driveways
18.5'	Above Public Driveways, Alleys, Roads, and Other Areas Subject to Truck & Construction Traffic.

Note: If minimum vertical clearance cannot be maintained with the above installation. The customer shall install steel service masts (See Figure 32).

All Equipment Furnished and Installed By Customer Unless Otherwise Noted.

01-29-20	SMS
08-12-19	KMH
06/16/07	SDS
07/15/06	SDS
REVISIONS	



200 Amp to 1200 Amp Current Transformer Overhead Service	
DRAWN: LU	DWG. NO. G18A2119
SCALE: NTS	FIGURE 31
DATE:01/01/96	

Figure 31: 200 Amp to 1200 Amp CT Metering, Overhead Service

Enough wire shall be provided from the Weatherhead(s) to make a common point connection on the line side of the Current Transformers. The polarity mark side (normally a white dot on the face of the Current Transformer window) shall be placed so that it is facing the line side connections.

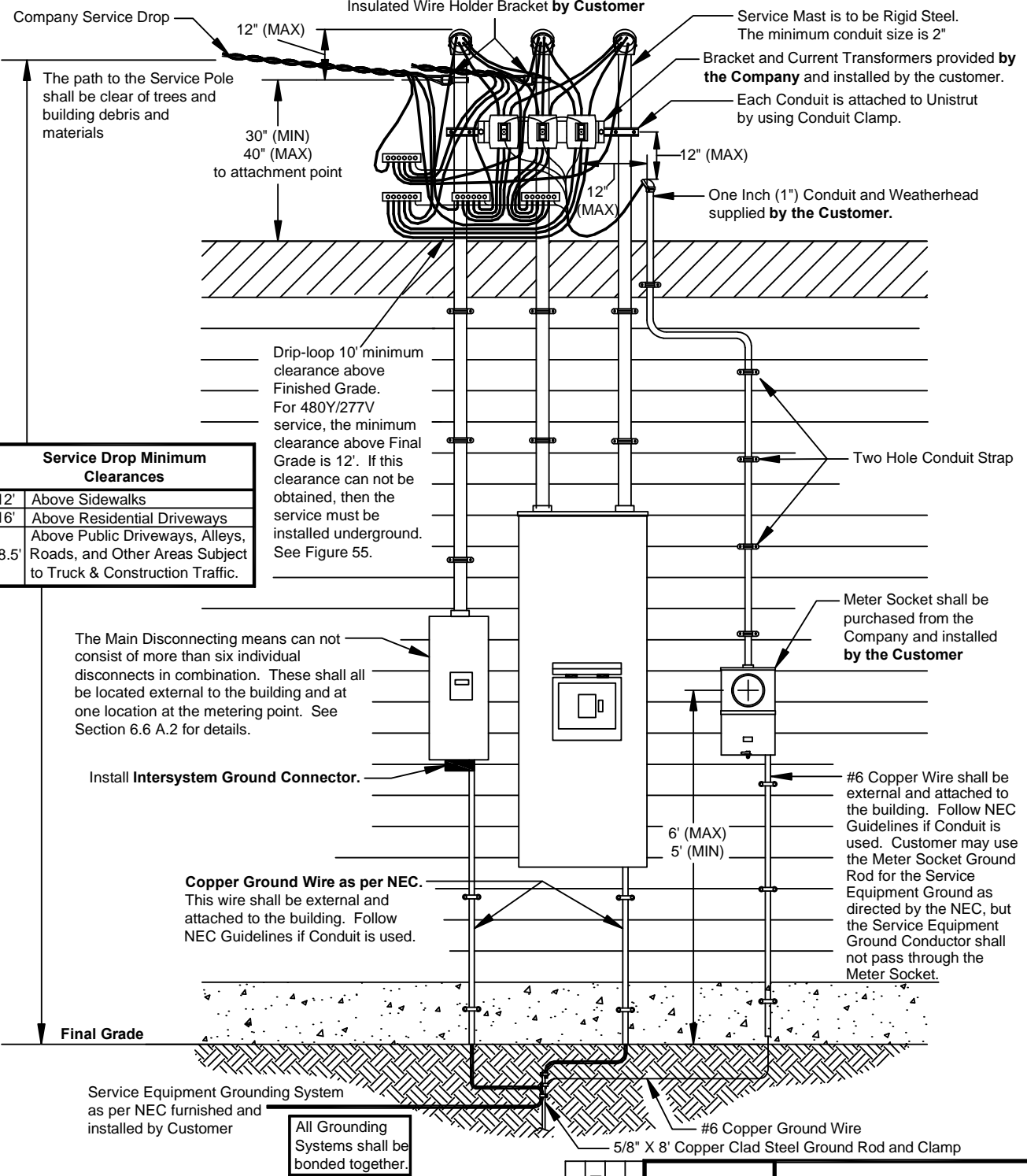

Service Drop Minimum Clearances	
12'	Above Sidewalks
16'	Above Residential Driveways
18.5'	Above Public Driveways, Alleys, Roads, and Other Areas Subject to Truck & Construction Traffic.

All Equipment Furnished and Installed By Customer Unless Otherwise Noted

01-29-20 SMS
08-27-19 KMH
07-15-06 SDS
REVISIONS



200A to 1200A C.T. Metering With Service Masts	
DRAWN: LU	DWG. NO. G18A2120
SCALE: NTS	FIGURE 32
DATE:01/01/96	

Figure 32: 200 Amp to 1200 Amp CT Metering, With Service Masts

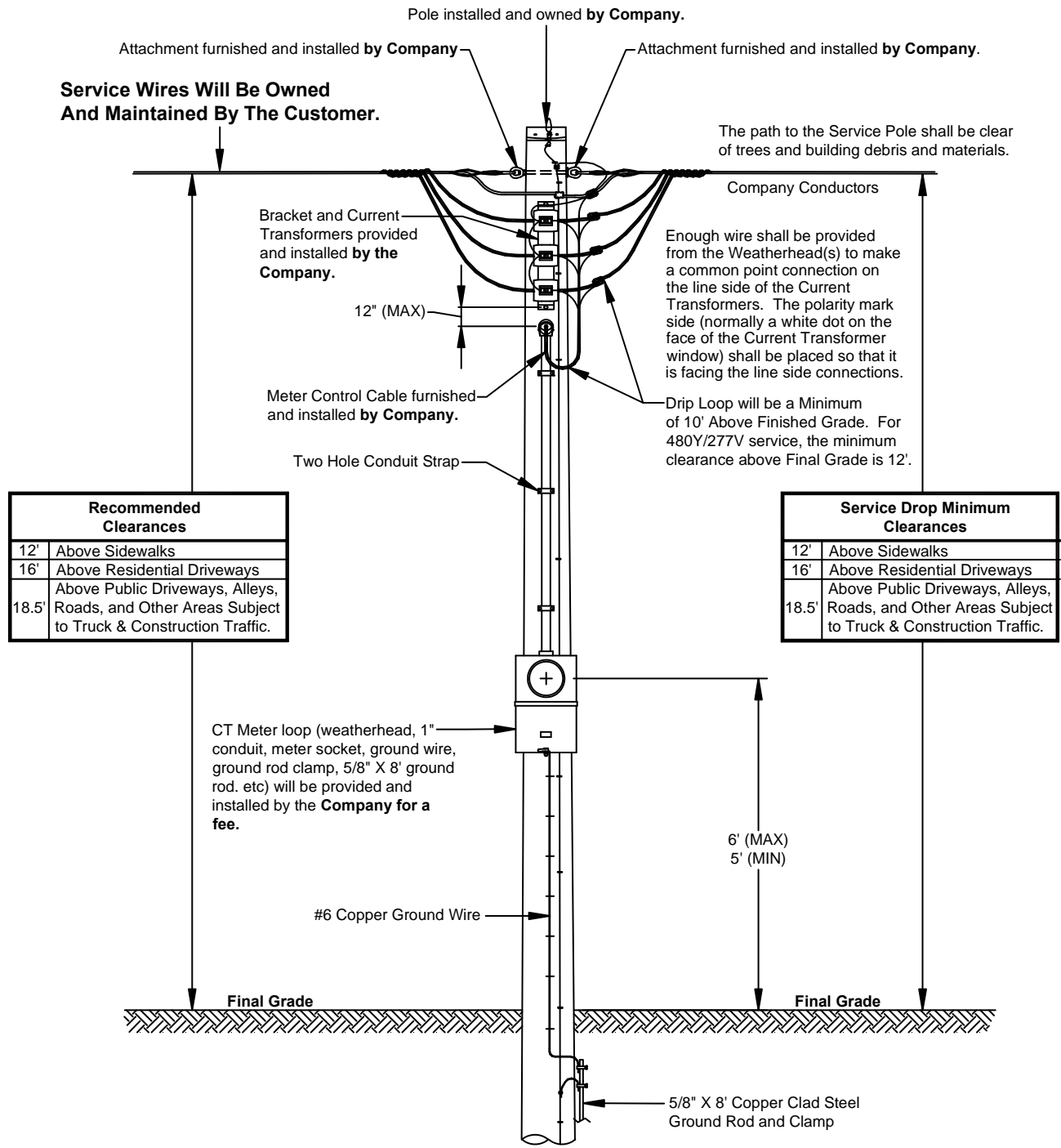

Meter Loop will not be installed on Primary Power Poles.

01-29-20 SMS 08-14-19 KMH 07-15-06 SDS REVISIONS		200A to 1200A C.T. Metering, Meter Pole	
		DRAWN: LU	DWG. NO. G18A2121
		SCALE: NTS	FIGURE 33
		DATE:01/01/96	

Figure 33: 200 Amp to 1200 Amp CT Metering, Meter Pole

THIS PAGE INTENTIONALLY LEFT BLANK

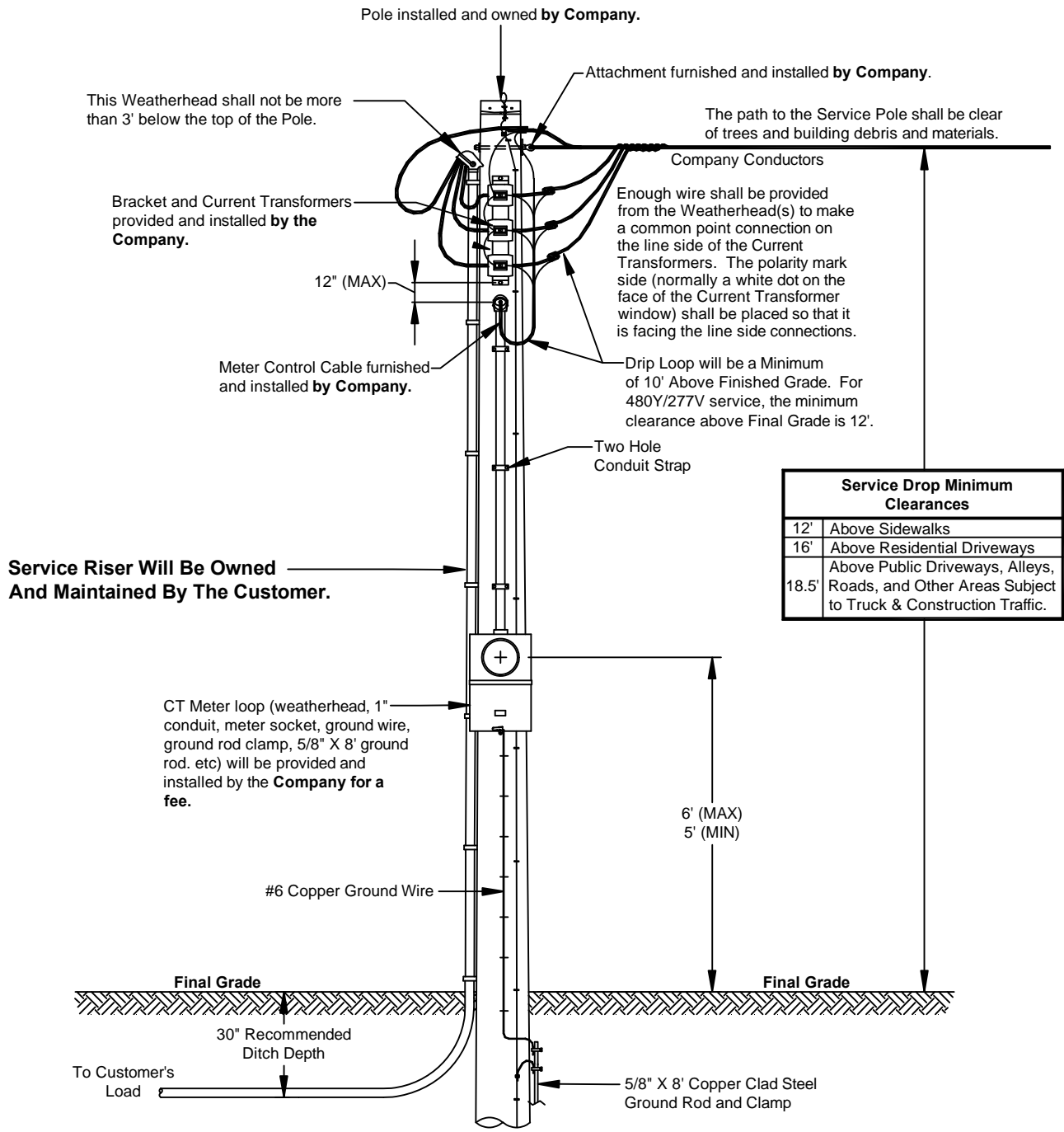

Meter Loop will not be installed on Primary Power Poles.

01-29-20 SMS	07-19-19 KMH	07/15/06 SDS	REVISIONS	200A to 1200A C.T. Metering Pole Underground Feeder	
				DRAWN: LU	DWG. NO. G18A2122
				SCALE: NTS	FIGURE 34
				DATE:01/01/96	

Figure 34: 200 Amp to 1200 Amp CT Metering, Meter Pole

6.7 MULTIPLE METERS, THREE PHASE OVERHEAD SERVICE

A. General Notes:

1. If more than six meters are required, consult the Company for approval of equipment prior to purchase.
2. Service entrance conductors, 5/8" x 8' copper clad steel ground rod, ground rod clamp, ground wire, conduit, conduit straps, weatherhead, lock nuts, bushings, meter socket assembly, meter socket assembly hub, service drop attachment device, and miscellaneous mounting hardware furnished and installed by the Customer.
3. Meters, service connectors, and service drop furnished and installed by Company.
4. The meter socket assembly should be "readily accessible" (see definitions). The Company requires a level and unobstructed work space of 78 inches tall, 18 inches on either side, and 48 inches in front of the meter socket assembly. Prior approval is required for placement of the meter socket assembly in alleyways or areas where it may be subjected to damage.
5. If the Company is required to attach the service drop directly to the Customer's meter loop conduit, the Customer shall install a steel service mast.
6. The meter sockets shall meet the following specifications:
 - a. The latest revision of U.L. 414 and ANSI C12.7 Standards.
 - b. Must be U.L. listed.
 - c. Must have grounding connector for quadruplex.
 - d. Lug size – 2/0 minimum.
 - e. On 208/120v 4 Wire WYE services, the customer must provide the meter socket with 5th lug installed in the 9 o'clock position.
 - f. All meter sockets shall be equipped L&G HQ-7 or equivalent heavy duty jaw clamping & bypass socket mechanism.
 - g. See Appendix A for list of approved meter sockets.**

B. Mounting:

1. Meter socket assembly, ground wire, and conduit shall be surface mounted and be securely fastened to the structure. The meter socket assembly shall be installed in a level and plumb position. **Flush mounted or recessed metering equipment and service riser conduit embedded in a wall will not be permitted.**
2. Where the exterior wall is other than brick or concrete blocks, a support frame shall be installed behind the exterior wall to provide a solid mounting surface for the meter socket assembly.
3. Meter sockets, metering cabinets, and conduit straps shall be installed with the following:
 - a. Lead anchors or double helix concrete screws shall be used with brick or solid concrete surfaces.
 - b. Toggle bolts shall be used with other masonry siding.
 - c. Wood screws shall be used with solid wood surfaces.
 - d. All mounting hardware shall be minimum #12(1/4") corrosion resistant screws.
 - e. A minimum of 4 fasteners shall be used to install any socket or cabinet unless specifically stated otherwise.

4. An intersystem bonding termination bar shall be installed to facilitate the connection of other utility's ground to a common ground. The location of this device shall be located directly below the meter socket or meter combination socket.

a. See Appendix A for list of approved intersystem bonding termination bars.

5. Wire not enclosed in conduit shall be a minimum of 36 inches away from any window or door opening.

C. Connections:

1. The Customer is responsible for termination of the incoming wiring if the wire terminates in a main breaker or fuse holder. The Company will terminate the incoming wire if it terminates on bus bar terminals. The main breaker will be removed when the service wire is being pulled by the Company.
2. Do not score line or load wire when removing insulation.
3. The Customer shall use wire brush or sandpaper to clean all conductors, apply a non-grit type inhibitor and tighten to manufacturer's specifications.

D. Meter Socket Marking:

1. **Before the meters are installed, each socket position and corresponding building unit, i.e. apt number or letter, Suite number or letter, tenant number or letter, or physical address served shall be accurately, clearly, and permanently labeled with an engraved plaque. These shall be screwed, bolted or riveted externally to the equipment. See figures for proper location. If the equipment is marked incorrectly, the customer shall be responsible for all costs incurred by LU for correcting the meter socket identification. Please note that marker ink or adhesive labels are examples of non-permanent labeling.**
2. **Letters or numbers on the engraved plaque shall be a minimum of one (1) inch in height of contrasting color, i.e., black and white, red and green, orange and blue, etc.**

E. Conductor Marking:

1. All neutral conductors shall be clearly marked with white tape at the point of delivery and at the meter socket assembly.
2. The power leg of each 240/120 volt, three-phase, four-wire delta service shall be clearly marked with orange tape at the point of delivery and at the meter socket assembly.

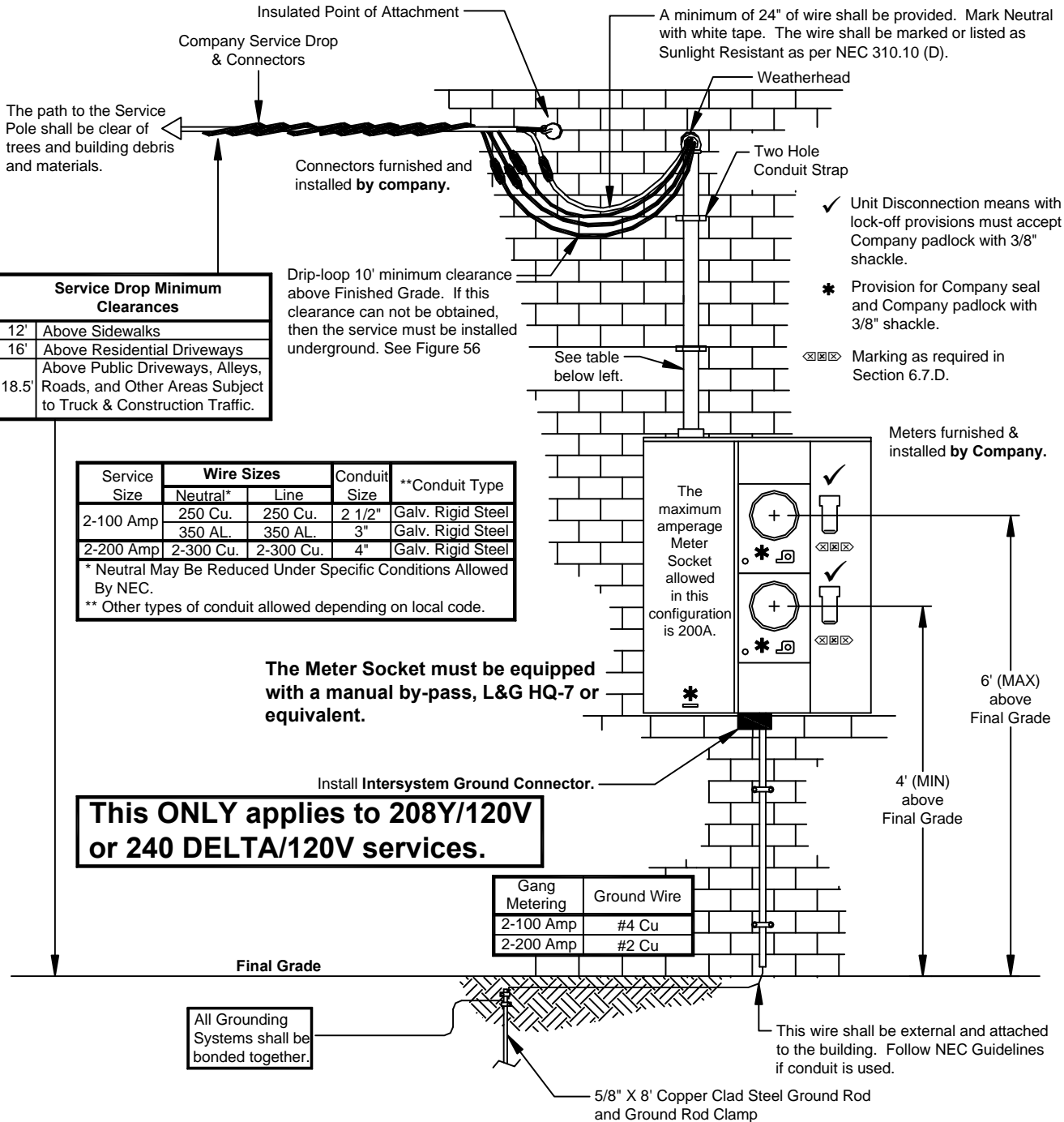

NOTES:

- Connections between service drop and service entrance conductors shall be made by Company personnel below weatherhead, forming a Drip Loop.
- Other types of conduit may be allowed depending on Local Code Requirements. These may include EMT, Electrical Grade (schedule 80) PVC, and Rigid Aluminum. **However, the Service Drop shall not be attached to any of these.**

All Equipment Furnished & Installed By Customer Unless Otherwise Noted.

08/27/19 KMH 07/13/09 SDS 07/15/06 SDS REVISIONS		Wiring of two Meters, Overhead Service	
		DRAWN: LU	DWG. NO. G18A2123
		SCALE: NTS	FIGURE 35
		DATE:01/01/96	

Figure 35: Wiring of Two Meters, Overhead Service

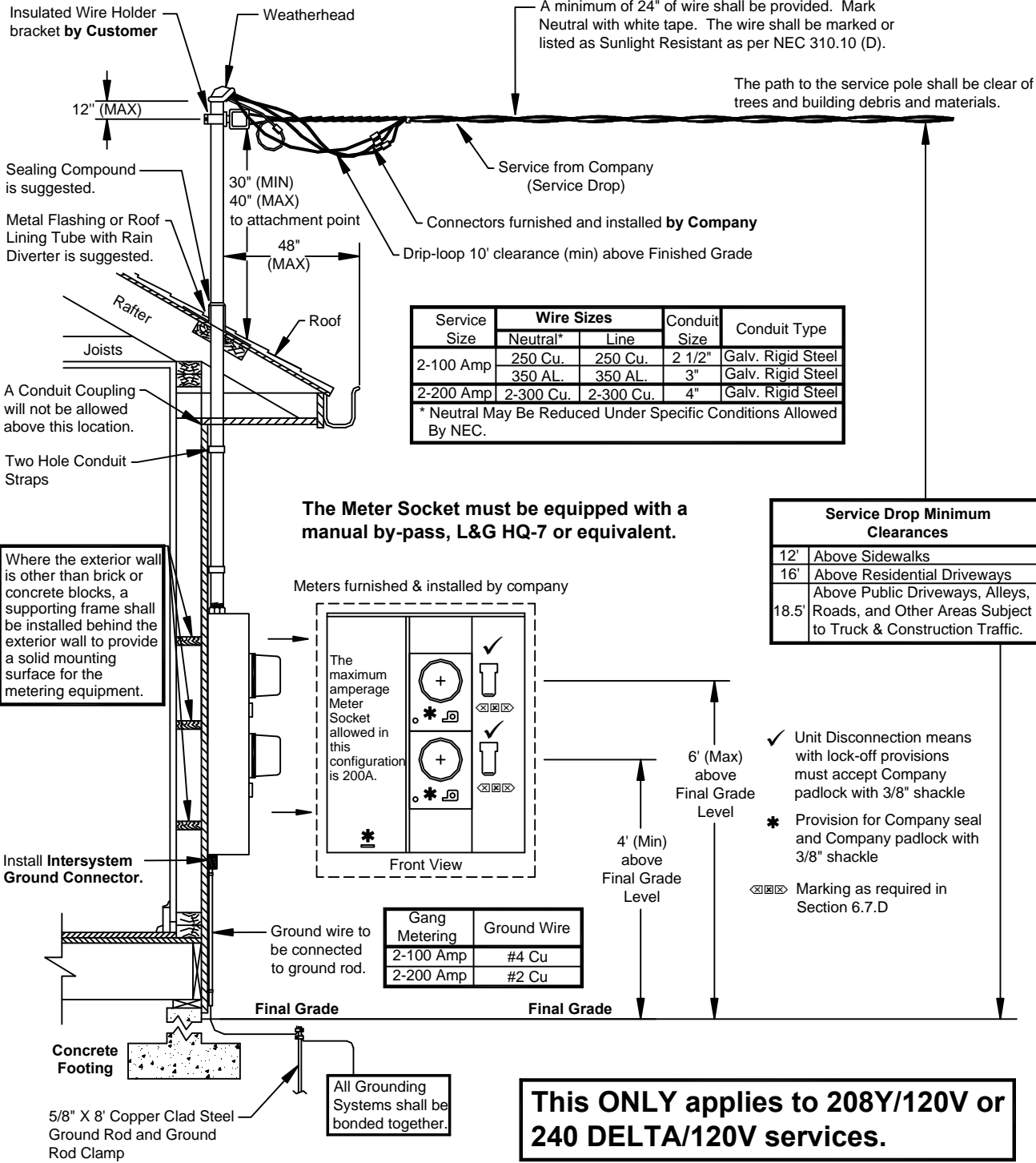

Service Size	Wire Sizes		Conduit Size	Conduit Type
	Neutral*	Line		
2-100 Amp	250 Cu.	250 Cu.	2 1/2"	Galv. Rigid Steel
	350 AL.	350 AL.	3"	Galv. Rigid Steel
2-200 Amp	2-300 Cu.	2-300 Cu.	4"	Galv. Rigid Steel

* Neutral May Be Reduced Under Specific Conditions Allowed By NEC.

Service Drop Minimum Clearances	
12'	Above Sidewalks
16'	Above Residential Driveways
18.5'	Above Public Driveways, Alleys, Roads, and Other Areas Subject to Truck & Construction Traffic.

The Meter Socket must be equipped with a manual by-pass, L&G HQ-7 or equivalent.

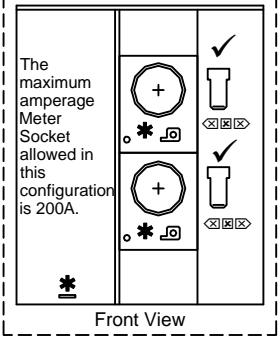

Gang Metering	Ground Wire
2-100 Amp	#4 Cu
2-200 Amp	#2 Cu

This ONLY applies to 208Y/120V or 240 DELTA/120V services.

All Equipment Furnished and Installed By Customer Unless Otherwise Noted.

08/27/19 KMH 07/15/06 SDS REVISIONS		Wiring of two Meters, Overhead Service using a Steel Service Mast	
		DRAWN: LU	DWG. NO. G18A2124
		SCALE: NTS	FIGURE 36
		DATE: 01/01/96	

Figure 36: Wiring of Two Meters, Overhead Service using a Steel Service Mast

THIS PAGE INTENTIONALLY LEFT BLANK

A minimum of 24" of wire shall be provided **by the customer**. Mark Neutral with white tape. The wire shall be marked or listed as Sunlight Resistant as per NEC 310.10 (D).

The path to the Service Pole shall be clear of trees and building debris and materials

Company Service Drop & Connectors

Drip-loop 10' clearance (min) above Finished Grade. If this clearance can not be obtained, then the service must be installed underground. See Figure 57.

Insulated Point of Attachment

The number, type, and size of conduits will vary with each installation. Contact Liberty Utilities for more information.

Service Drop Minimum Clearances	
12'	Above Sidewalks
16'	Above Residential Driveways
18.5'	Above Public Driveways, Alleys, Roads, and Other Areas Subject to Truck & Construction Traffic.

Two Hole Conduit Strap

Where the exterior wall is other than brick or concrete blocks, a supporting frame shall be installed behind the exterior wall to provide a solid mounting surface for the metering equipment.

- * Provision for Company seal and company padlock with 3/8" shackle.
- ☒☒☒ Marking as required in Section 6.7.D.
- ✓ Unit disconnection means lock-off provisions must accept Company padlock with 3/8" shackle.

Either install a #6 copper wire (Minimum) from the same connection point as the main Copper Ground Wire connection in the multi-meter incoming compartment or the ground rod to **Intersystem Ground Connector**.

The Meter Sockets must be equipped with a manual by-pass, L&G HQ-7 or equivalent.

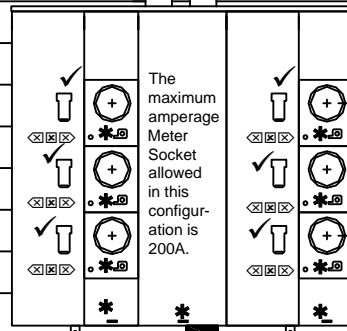

6' (MAX) above Final Grade

3' (MIN) above Final Grade

Copper Ground Wire as per NEC. This wire shall be external and attached to the building. Follow NEC Guidelines if conduit is used.

Final Grade

A minimum of one 5/8" X 8' Copper Clad Steel Ground Rod shall be provided **by Customer**. However, more than one Ground Rod may be needed. Consult NEC for requirements.

All Grounding Systems shall be bonded together.

Notes:

1. Connections between Service Drop and Service Entrance Conductors shall be made by Company personnel below Weatherhead, forming a Drip Loop.
2. Galvanized rigid steel conduit is recommended. Other types of conduit, i.e. electrical grade (schedule 80) PVC or rigid Aluminum, may be allowed depending on the local code requirements.
3. Service Entrance Conductors shall be sized as per NEC.

If more than 6 meters are required, please contact the Company for configuration. As a minimum, Liberty Utilities will require the riser diagram and cut sheets as proposed by the Electrical Engineer.

All Equipment Furnished and Installed By Customer Unless Otherwise Noted.

08/12/19 KMH 03/18/10 SDS 07/15/06 SDS REVISIONS		Three to Six Meters, Overhead Service	
		DRAWN: LU	DWG. NO. G18A2125
		SCALE: NTS	FIGURE 37
		DATE:01/01/96	

Figure 37: Three to Six Meters, Overhead Service

7.0 UNDERGROUND SERVICES

7.1 GENERAL INFORMATION

1. PLEASE CONTACT THE COMPANY BEFORE PLANNING FOR AN UNDERGROUND SERVICE.
2. MINIMUM CLEARANCES OF SERVICE LATERALS IN CONDUIT

Horizontal from gas, water, and sewer lines	5 feet
Horizontal from telephone or cable television lines	1 foot
Horizontal to any structures (including footings and foundations).	5 feet
Horizontal from conductor to edge of swimming pool	10 feet

(This is for either an above ground or in ground swimming pool)

Note: If within ten feet of service point, this clearance does not apply to structures served.

3. Help avoid the need for future trimming by planting trees and shrubs in the right place.

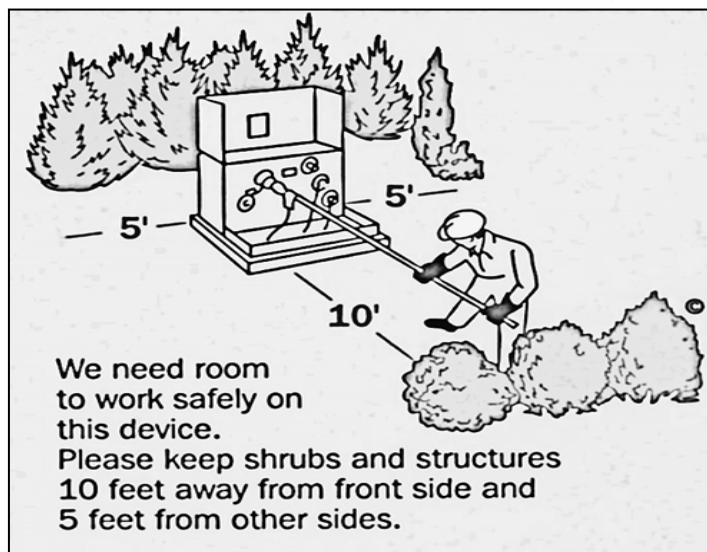

4. The service lateral shall not cross a sewer lateral field.
5. **The Customer shall request the Company to designate the location of the point of delivery for each service location before construction is started.**
6. Before doing any excavation, contact all Utilities to locate their underground facilities. The following are the One Call numbers for each state listed.

Missouri	(800) 344 – 7483
Kansas	(800) 344 – 7233
Arkansas	(800) 482 – 8998
Oklahoma	(800) 522 – 6543
7. The Customer will be held responsible to locate and mark all privately owned (Customer's or other's) underground facilities.
8. Guard Posts maybe required on any underground service installation to protect the Company's Equipment. Contact the Company for requirements.

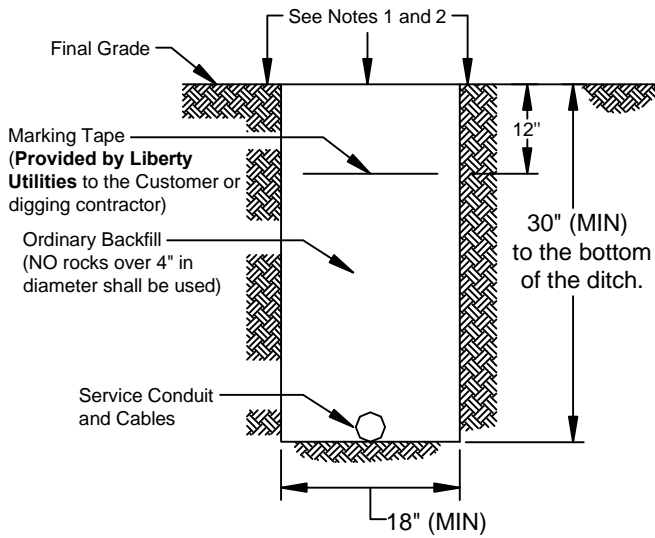

Caution!
Contact all Utilities
before digging

NOTES:

1. Backfill shall be compacted with the wheels of the excavation equipment or by other suitable means prior to final backfilling. The top of the backfilled trench shall be approximately level with the surrounding grade. Excess soil shall be hauled away. Final backfilling and cleanup shall not be done during adverse weather conditions.
2. An area on each side of the trench will be disturbed by the trenching, backfilling and cleanup operations. The area shall be leveled with the surrounding grade and cleanup, and it is the responsibility of the property owner to replant it with grass and to do any future landscaping that might be needed.

Ditch Profile

Service is provided as line of sight from Meter Socket location to service source. If the service route differs from this due to obstructions or terrain or is longer than 100 feet, **contact Liberty Utilities for requirements. Additional cost may apply.**

The Company will provide and install the conduit system for a fee from a point four foot away from the structure.

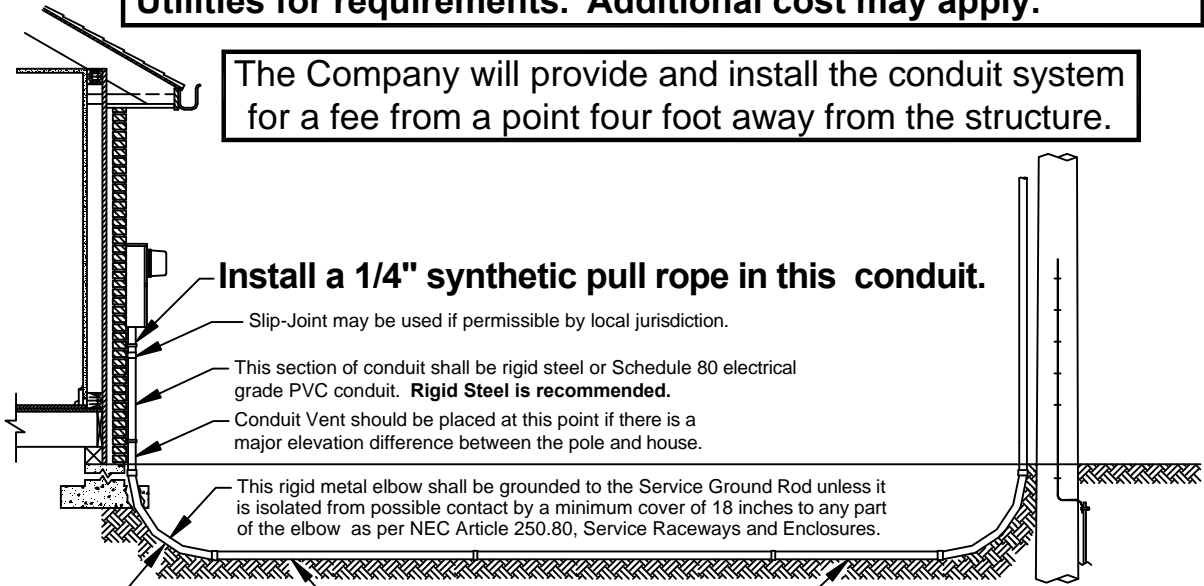

Install a 1/4" synthetic pull rope in this conduit.

Slip-Joint may be used if permissible by local jurisdiction.

This section of conduit shall be rigid steel or Schedule 80 electrical grade PVC conduit. **Rigid Steel is recommended.**

Conduit Vent should be placed at this point if there is a major elevation difference between the pole and house.

This rigid metal elbow shall be grounded to the Service Ground Rod unless it is isolated from possible contact by a minimum cover of 18 inches to any part of the elbow as per NEC Article 250.80, Service Raceways and Enclosures.

!!!! WARNING !!!!

If this elbow is not supported or if the soil under it is not well compacted, the conduit may pull out of the meter socket resulting in a possible failure of the service.

Electrical grade schedule 40 PVC or rigid steel conduit will be used in this area.

DO NOT USE WHITE WATER PIPE.

This denotes undisturbed earth.

If the Customer digs the ditch, a Ditch Inspection is REQUIRED. Contact the Company to schedule an inspection.

07/19/19	KMH
04/01/09	SDS
05/17/05	SDS
REVISIONS	



Underground Service Detail	
DRAWN: SDS	DWG. NO. G18A2126
SCALE: NTS	FIGURE 38
DATE:06/06/03	

Figure 38: Underground Service Detail

**Caution !
Contact all Utilities
before digging**

**The Company will provide and install the conduit system
for a fee from a point four foot away from the structure.**

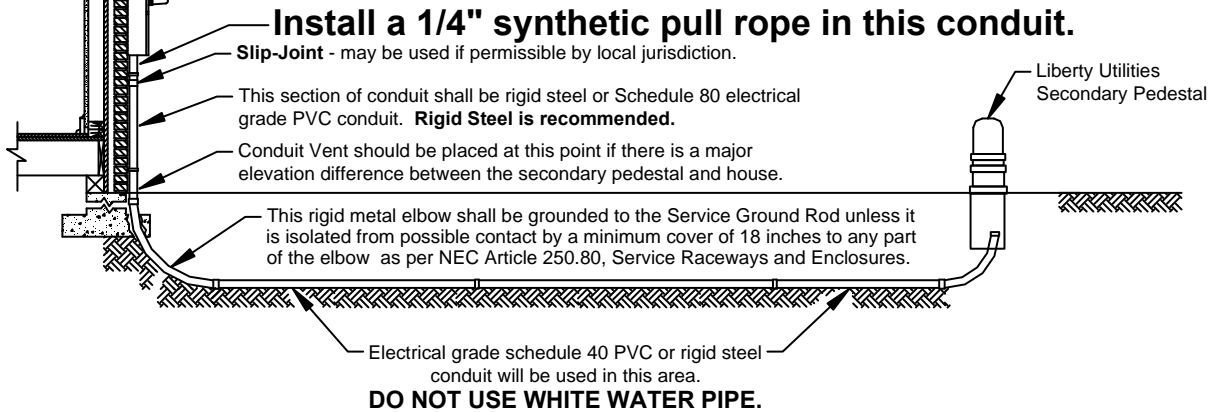

**Service is provided as line of sight from Meter Socket location to
service source. If the service route differs from this due to
obstructions or terrain or is longer than 100 feet, contact Liberty
Utilities for requirements. Additional cost may apply.**

**The Company will provide and install the conduit system
for a fee from a point four foot away from the structure.**

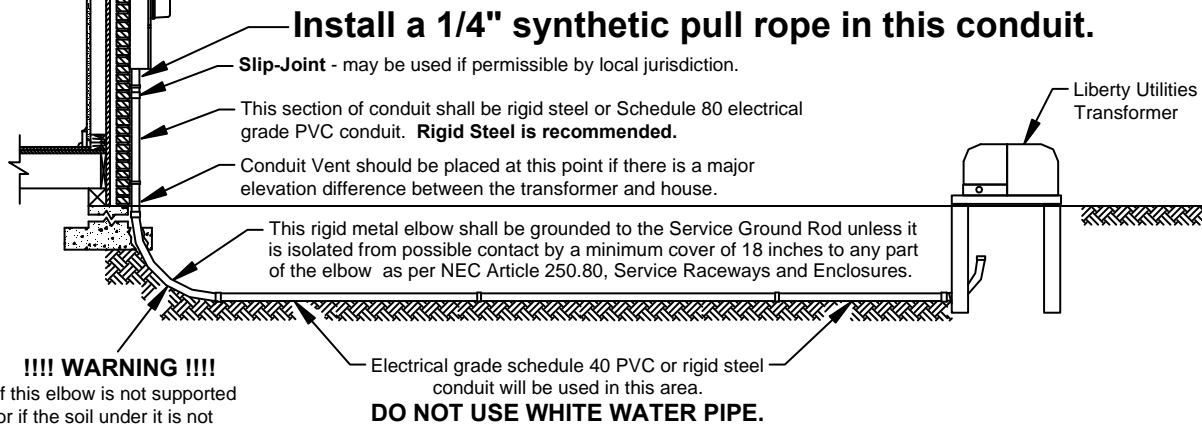

!!!! WARNING !!!!
If this elbow is not supported
or if the soil under it is not
well compacted, the conduit
may pull out of the meter
socket resulting in a possible
failure of the service.

 This denotes undisturbed earth.

**If the Customer digs the ditch, a Ditch
Inspection is REQUIRED. Contact the
Company to schedule an inspection.**

07/19/19	KMH	REVISIONS
04/01/09	SDS	



Underground Service Detail (Continued)	
DRAWN: SDS	DWG. NO. G18A2127
SCALE: NTS	FIGURE 39
DATE: 07/15/06	

Figure 39: Underground Service Detail (Continued)

Service Equipment shall be installed as shown in these Service Standards. Install this equipment on front side of this structure.

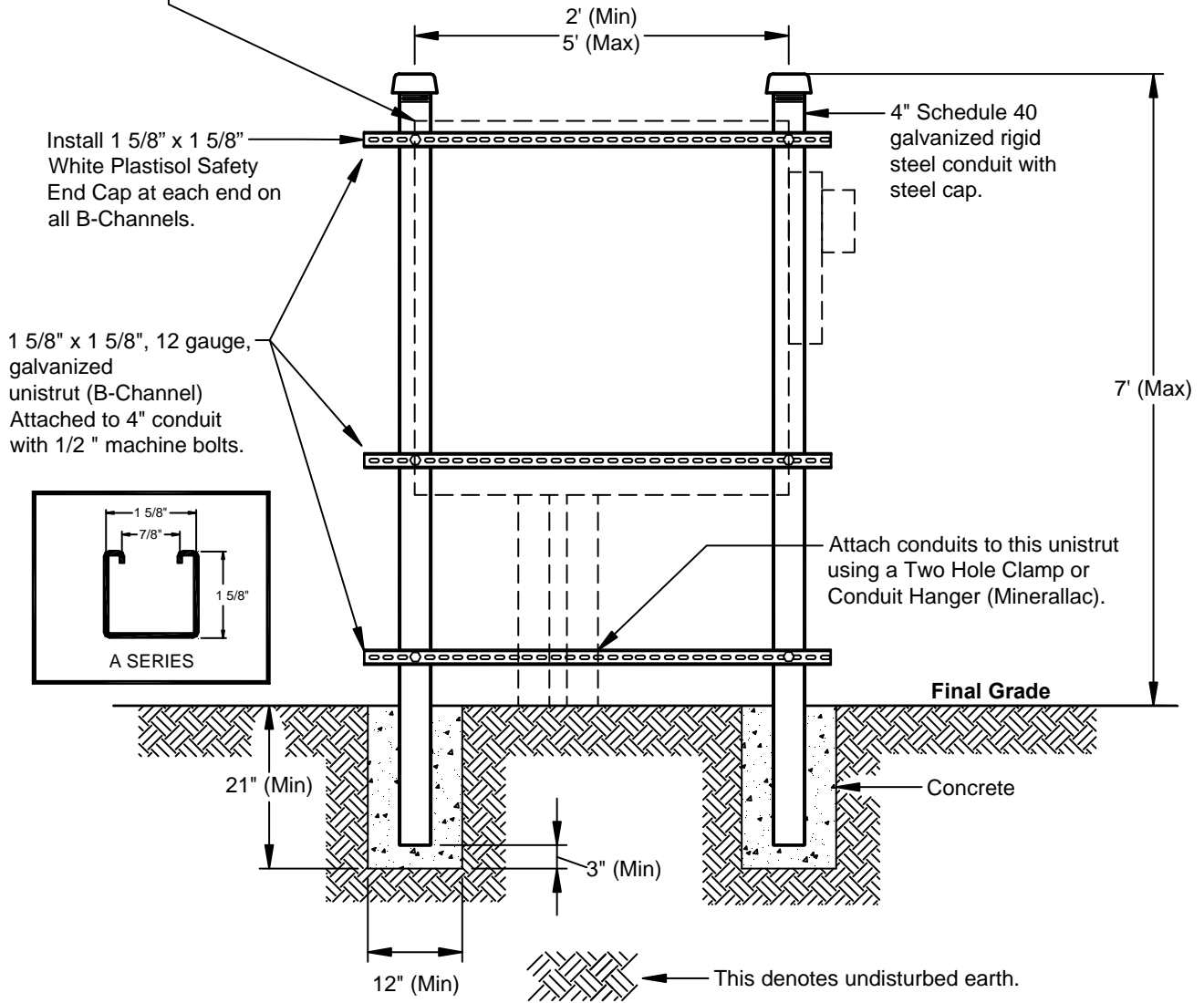

Contact Liberty Utilities for the location, orientation, and/or verification before installing this structure.

**Caution!
Contact all Utilities
before digging**

All Equipment Furnished & Installed By Customer Unless Otherwise Noted.

05/16/18 KMH REVISIONS		Underground Service Structure	
		DRAWN: SDS	DWG. NO. G18A2128
		SCALE: NTS	FIGURE 40
		DATE: 07/15/06	

Figure 40: Underground Service Structure

7.2 200 AMP AND 320 AMP SINGLE PHASE UNDERGROUND SERVICE

A. General Notes:

1. Service entrance conductors, 5/8" x 8' copper clad steel ground rod, ground rod clamp, ground wire, conduit, conduit straps, lock nuts, bushings, 200 amp meter socket, main disconnect, hub closing plate, and miscellaneous mounting hardware furnished and installed by customer.
2. Meter and service lateral conductors furnished and installed by Company.
3. The meter socket should be "readily accessible" (see definitions). The Company requires a level and unobstructed work space of 78 inches tall, 18 inches on either side, and 48 inches in front of the meter socket. Prior approval is required for placement of the meter socket in alleyways or areas where it may be subjected to damage.
4. The 200 amp and 320 amp meter sockets shall meet the following specifications:
 - a. The latest revision of U.L. 414 and ANSI C12.7 Standards.
 - b. Must be U.L. listed.
 - c. Must have grounding connector for triplex.
 - d. Lug size – 2/0 minimum.
 - e. On 120/208v services the customer must provide the meter socket and 5th lug installed in the 9 o'clock position.
 - f. See Appendix A for list of approved meter sockets.**
5. Conduit system shall be installed as per Figure 38 or 39.

B. Mounting:

1. Meter socket, ground wire, and conduit shall be surface mounted and securely fastened to the exterior structure. The meter socket shall be installed in a level and plumb position. **Flush mounted metering or recessed equipment and service lateral conduit embedded in a wall will not be permitted.**
2. Where the exterior wall is other than brick or concrete blocks, a frame shall be installed behind the exterior wall to provide a solid mounting surface for the meter socket.
3. Meter sockets, metering cabinets, and conduit straps shall be installed with the following:
 - a. Lead anchors or double helix concrete screws shall be used with brick or solid concrete surfaces.
 - b. Toggle bolts shall be used with other masonry siding.
 - c. Wood screws shall be used with solid wood surfaces.
 - d. All mounting hardware shall be minimum #12(1/4") corrosion resistant screws.
 - e. A minimum of 4 fasteners shall be used to install any socket or cabinet unless specifically stated otherwise.
4. An intersystem bonding termination bar shall be installed to facilitate the connection of other utility's ground to a common ground. The location of this device shall be located directly below the meter socket or meter combination socket.
 - a. See Appendix A for list of approved intersystem bonding termination bars.**

5. If PVC is used for the conduit attached to the meter socket, the rigid metal elbow shall be grounded/bonded to the service ground rod unless it is isolated from possible contact by a minimum cover of 18 inches to any part of the elbow as per NEC Article 250.80, Service Raceways and Enclosures.

a. See Appendix A for list of approved grounding clamps.

6. For 200 amp service, a minimum of two inch (2") galvanized rigid steel or electrical grade Schedule 80 PVC conduit shall be furnished and installed by Customer as shown in Figure 41.
7. For 320 amp service, a minimum of three inch (3") galvanized rigid steel or electrical grade Schedule 80 PVC conduit shall be furnished and installed by Customer as shown in Figure 41.

C. Connections:

1. Do not score load wire when removing insulation.
2. The customer shall use wire brush or sandpaper to clean all conductors, apply a non-grit type inhibitor and tighten to manufacturer's specifications.

D. Conductor Marking:

All neutral conductors shall be clearly marked with white tape at the meter socket.

Ground Rod and Wire MUST be Installed and Ground Wire MUST be attached to the structure before Service will be Connected.

200 amp Meter Socket and Disconnect or 200 amp combination meter socket shall be furnished **by the Customer**. When a disconnect is used, it shall be not be closer than 1" nor farther away than 1' from the meter socket. Disconnects are required on the 320 amp meter socket and shall be located on the exterior of the structure. If more than one disconnect is required, they shall all be placed at the same location. A 200 amp combination socket is shown.

Meter furnished and installed **by Company**
 Bypass Lever allowed on 320 amp meter socket only.

Service Size	Ground Wire
200 Amp	#4 Cu.
320 Amp	1/0 Cu.

This wire shall be external and attached to the building. Follow NEC Guidelines if Conduit is used

Service Size	Conduit Size	Recommended Conduit Type
200 Amp	2"	Galvanized Rigid Steel
320 Amp	3"	Galvanized Rigid Steel

Note: Sch 80 electrical grade PVC may be used.

Install Intersystem Ground Connector

Slip-Joint may be used if permissible by local jurisdiction.

Two Hole Conduit Strap or Conduit Hanger (Minerallac)

5/8" X 8' Copper clad steel ground rod & clamp

Final Grade

Concrete Footing

Ground elbow with grounding clamp See Note 5.

All Grounding Systems shall be bonded together.

4' to 6' Above Final Grade Level

30" (Min) Ditch Depth

Two Holed Conduit Strap or Conduit Hanger (Minerallac)
 Ground elbow with grounding clamp See Note 5.

Final Grade

Concrete Footing

All Grounding Systems shall be bonded together.

5/8" X 8' Copper clad steel ground rod & clamp

45° Galvanized rigid steel elbow

The conduit shall rest on the bottom of the trench and will point toward the service source. See Figure 38 and 39.

Sweep ell min. radius	
Conduit Size	Radius
2"	9.5"
3"	13"

Note: Galvanized Rigid Steel

Preferred

Alternate

This denotes undisturbed earth.

Caution!
Contact all Utilities before digging

!!!! WARNING !!!!
 If this elbow is not supported or if the soil under it is not well compacted, the conduit may pull out of the meter socket resulting in a possible failure of the service.

Notes:

1. If a conduit reducer is used, it must be located immediately below the Meter Socket.
2. Line of Sight installation is required. See Definitions.
3. A conduit vent may be needed depending on the service arrangement and terrain.
4. If the service route is longer than 100 feet, contact Liberty Utilities for conduit requirements.
5. A metal elbow that is installed in an underground installation of rigid nonmetallic conduit and is isolated from possible contact by a minimum cover of 18 inches to any part of the elbow shall not be required to be grounded as per NEC Article 250.80, Service Raceways and Enclosures.

All Equipment Furnished & Installed By Customer Unless Otherwise Noted.

07/31/20	TDK
07/08/19	KMH
04/01/09	SDS
07/15/06	SDS
05/17/05	SDS
01/01/97	AMA
REVISIONS	



200/320 Amp Underground Service	
DRAWN: LU	DWG. NO. G18A2129
SCALE: NTS	FIGURE 41
DATE:01/01/95	

Figure 41: 200/320 Amp, Underground Service

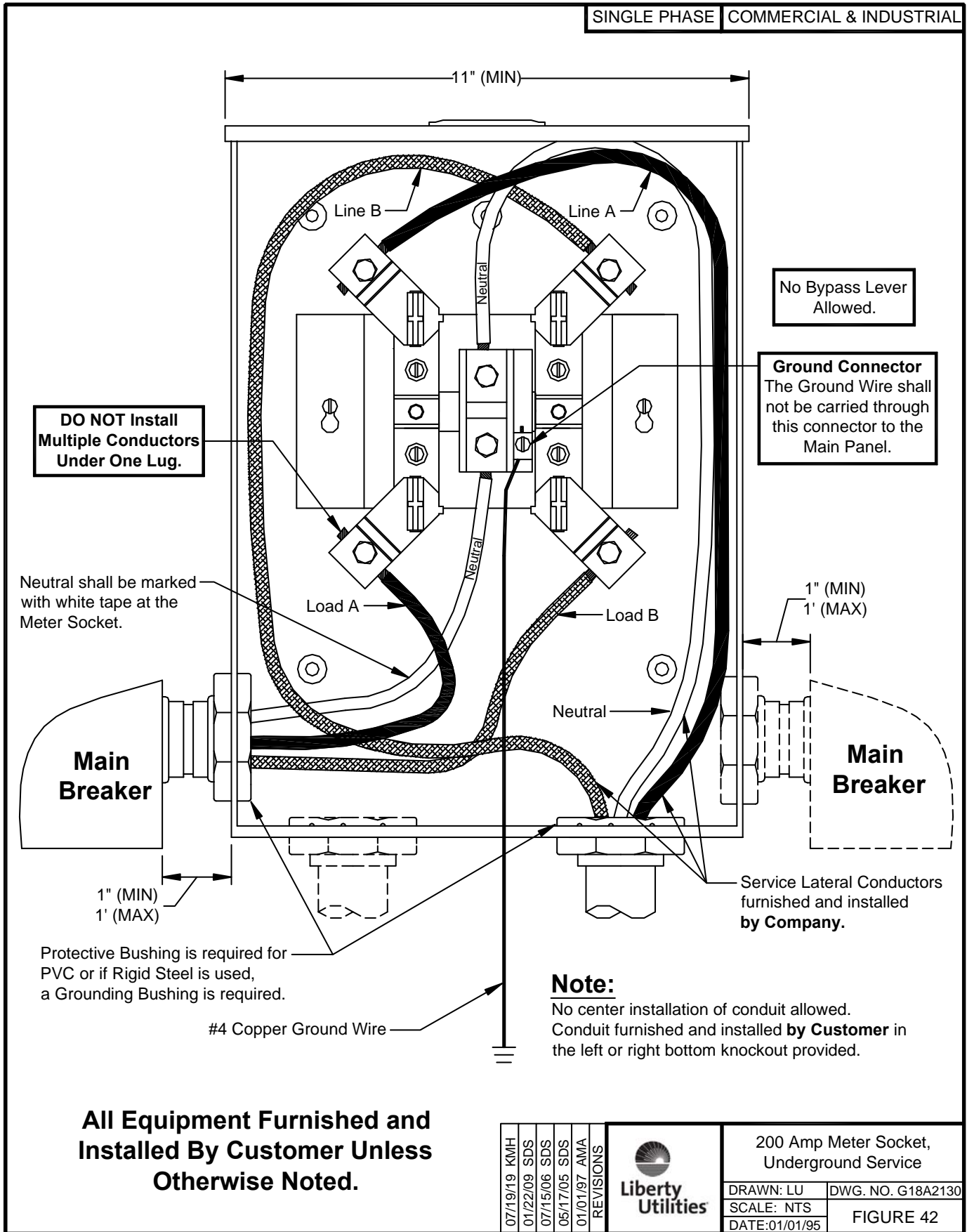

DO NOT Install Multiple Conductors Under One Lug.

No Bypass Lever Allowed.

Ground Connector
The Ground Wire shall not be carried through this connector to the Main Panel.

Neutral shall be marked with white tape at the Meter Socket.

Main Breaker

Main Breaker

1" (MIN)
1' (MAX)

Service Lateral Conductors furnished and installed by Company.

Protective Bushing is required for PVC or if Rigid Steel is used, a Grounding Bushing is required.

#4 Copper Ground Wire

Note:

No center installation of conduit allowed. Conduit furnished and installed by Customer in the left or right bottom knockout provided.

All Equipment Furnished and Installed By Customer Unless Otherwise Noted.

07/19/19	KMH
01/22/09	SDS
07/15/06	SDS
05/17/05	SDS
01/01/97	AMA
REVISIONS	



200 Amp Meter Socket, Underground Service	
DRAWN: LU	DWG. NO. G18A2130
SCALE: NTS	FIGURE 42
DATE:01/01/95	

Figure 42: 200 Amp Meter Socket, Underground Service

Note:
This application for 120/208v, 3 wire service.

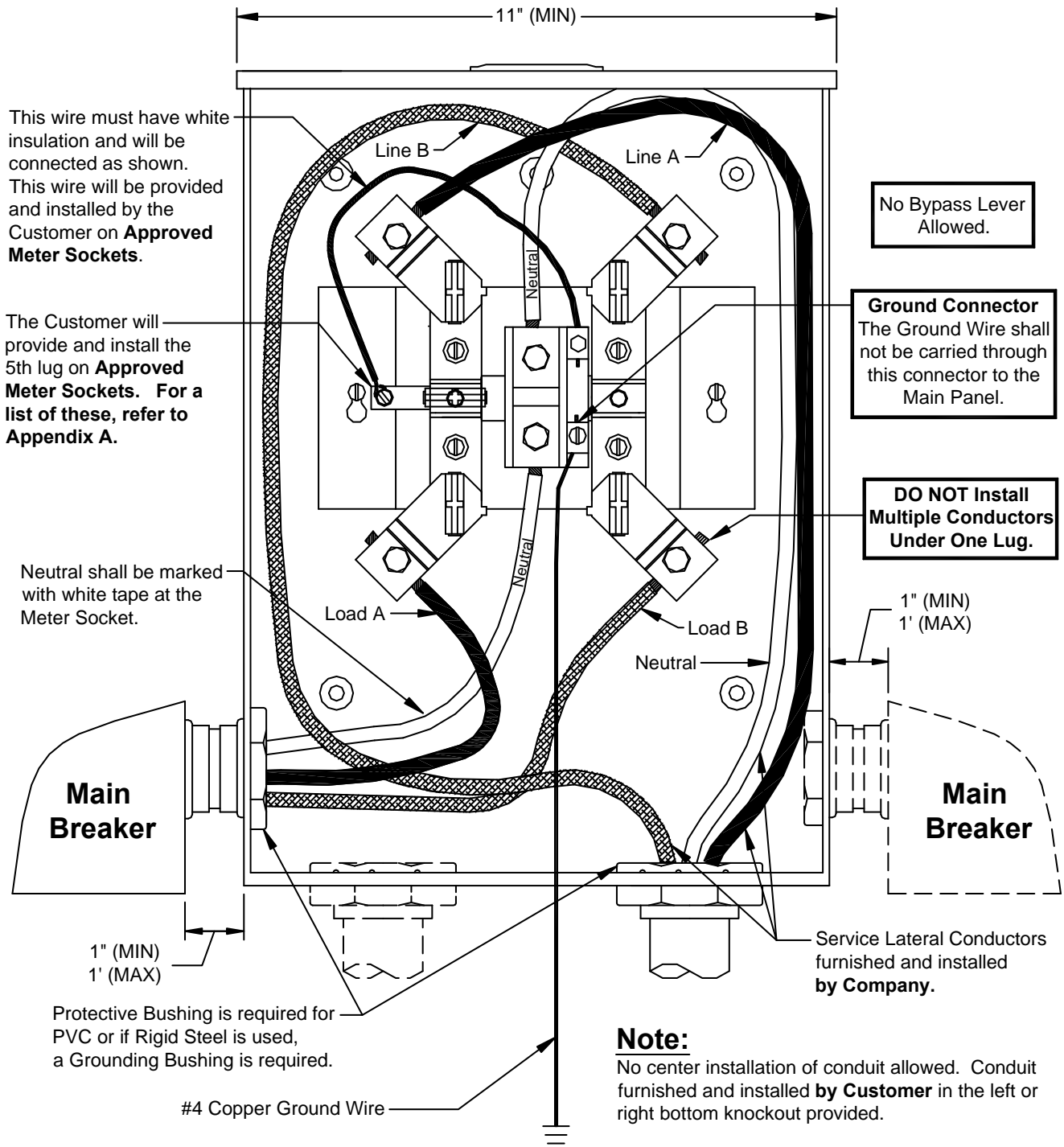

This wire must have white insulation and will be connected as shown. This wire will be provided and installed by the Customer on **Approved Meter Sockets**.

The Customer will provide and install the 5th lug on **Approved Meter Sockets**. For a list of these, refer to **Appendix A**.

Neutral shall be marked with white tape at the Meter Socket.

No Bypass Lever Allowed.

Ground Connector
 The Ground Wire shall not be carried through this connector to the Main Panel.

DO NOT Install Multiple Conductors Under One Lug.

Protective Bushing is required for PVC or if Rigid Steel is used, a Grounding Bushing is required.

Note:
 No center installation of conduit allowed. Conduit furnished and installed **by Customer** in the left or right bottom knockout provided.

All Equipment Furnished and Installed By Customer Unless Otherwise Noted.

07/19/19 KMH 01/22/09 SDS 07/15/06 SDS 05/17/05 SDS REVISIONS		200 Amp Meter Socket, Network (120/208), Underground Service	
		DRAWN: LU	DWG. NO. G18A2131
		SCALE: NTS	FIGURE 43
		DATE: 01/01/95	

Figure 43: 200 Amp Meter Socket, Network (120/208), Underground Service

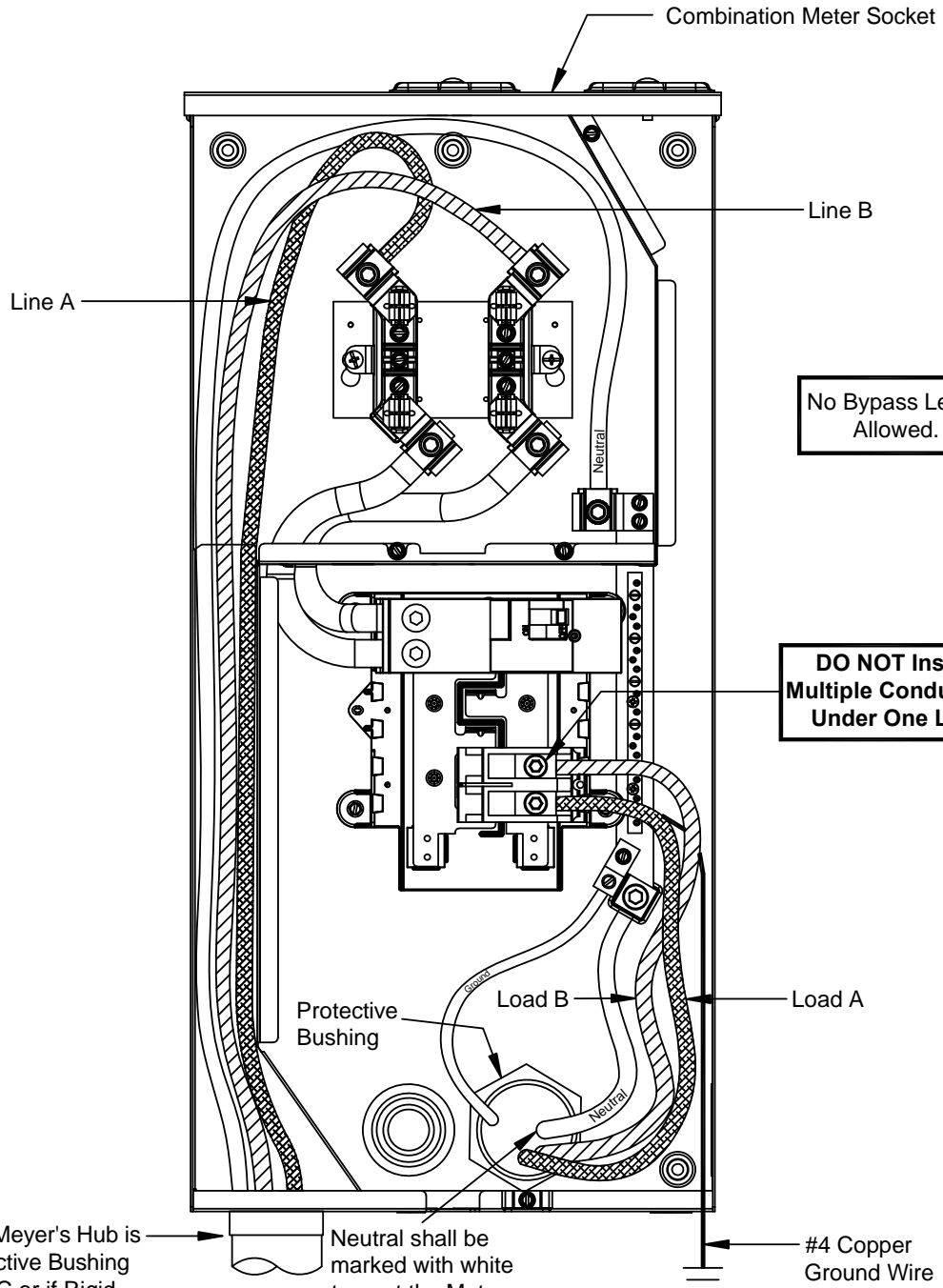

If a Hub Plate or Meyer's Hub is not used, a Protective Bushing is required for PVC or if Rigid Steel is used, a Grounding Bushing is required.

Neutral shall be marked with white tape at the Meter Socket.

Note:

No center installation of conduit allowed. Conduit furnished and installed **by Customer** in the left or right bottom knockout provided.

All Equipment Furnished and Installed By Customer Unless Otherwise Noted.

01/29/20	SMS
08/27/19	KMH
04/01/09	SDS
REVISIONS	



200 Amp Combination Meter Socket, Underground Service	
DRAWN: LU	DWG. NO. G18A2132
SCALE: NTS	FIGURE 44
DATE: 01/01/95	

Figure 44: 200 Amp Combination Meter Socket, Underground Service

Note:
This application for
120/208v, 3 wire service.

The Customer will provide and install the 5th lug on **Approved Meter Sockets.** For a list of these, refer to **Appendix A.**

This wire must have white insulation and will be connected as shown. This wire will be provided and installed by the Customer on **Approved Meter Sockets.**

DO NOT Install Multiple Conductors Under One Lug.

If a Hub Plate or Meyer's Hub is not used, a Protective Bushing is required for PVC or if Rigid Steel is used, a Grounding Bushing is required.

Neutral shall be marked with white tape at the Meter Socket.

Note:
 No center installation of conduit allowed. Conduit furnished and installed **by Customer** in the left or right bottom knockout provided.

All Equipment Furnished and Installed By Customer Unless Otherwise Noted.

06/11/20	SMS
01/29/20	SMS
08/27/19	KMH
04/01/09	SDS
REVISIONS	



200 Amp Combination Meter Socket, Network (120/208) Underground Service	
DRAWN: LU	DWG. NO. G18A2133
SCALE: NTS	FIGURE 45
DATE: 11/10/06	

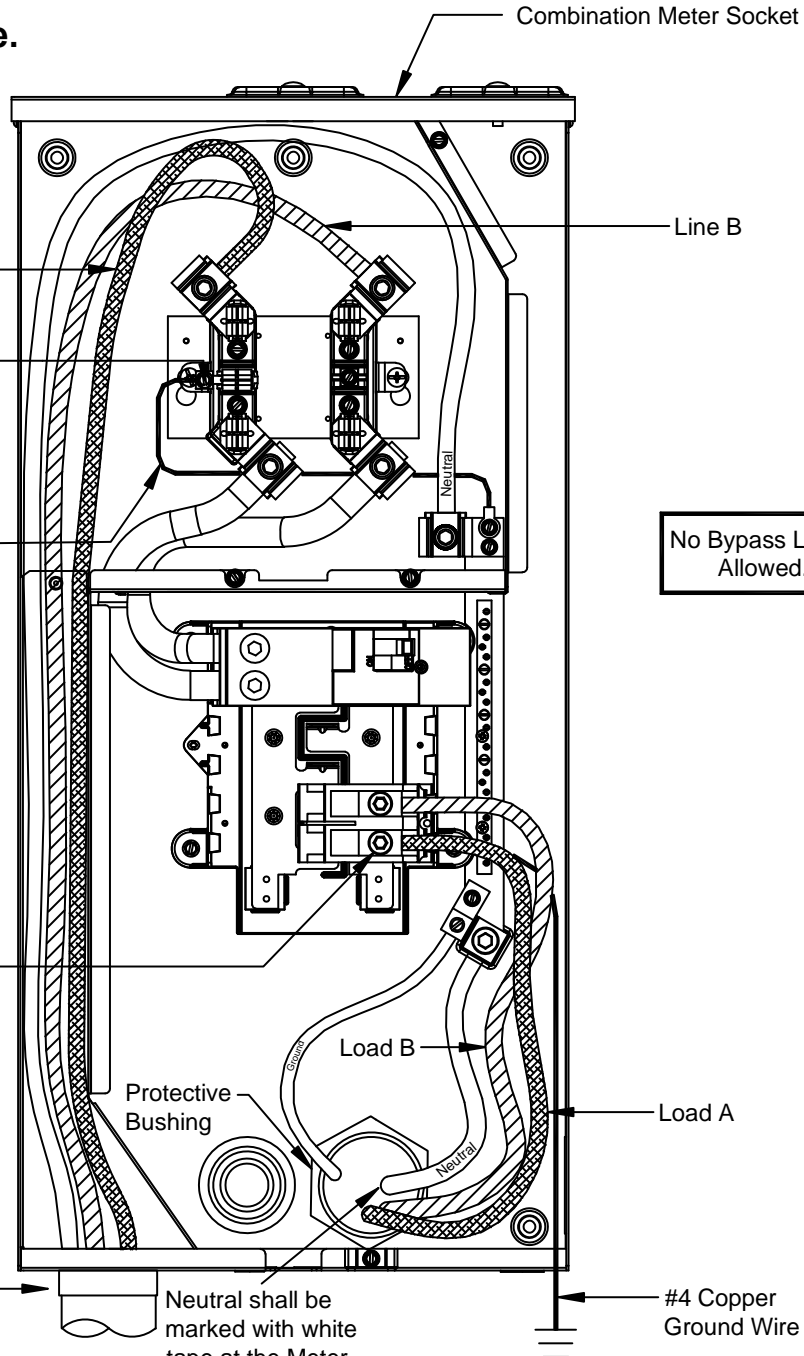
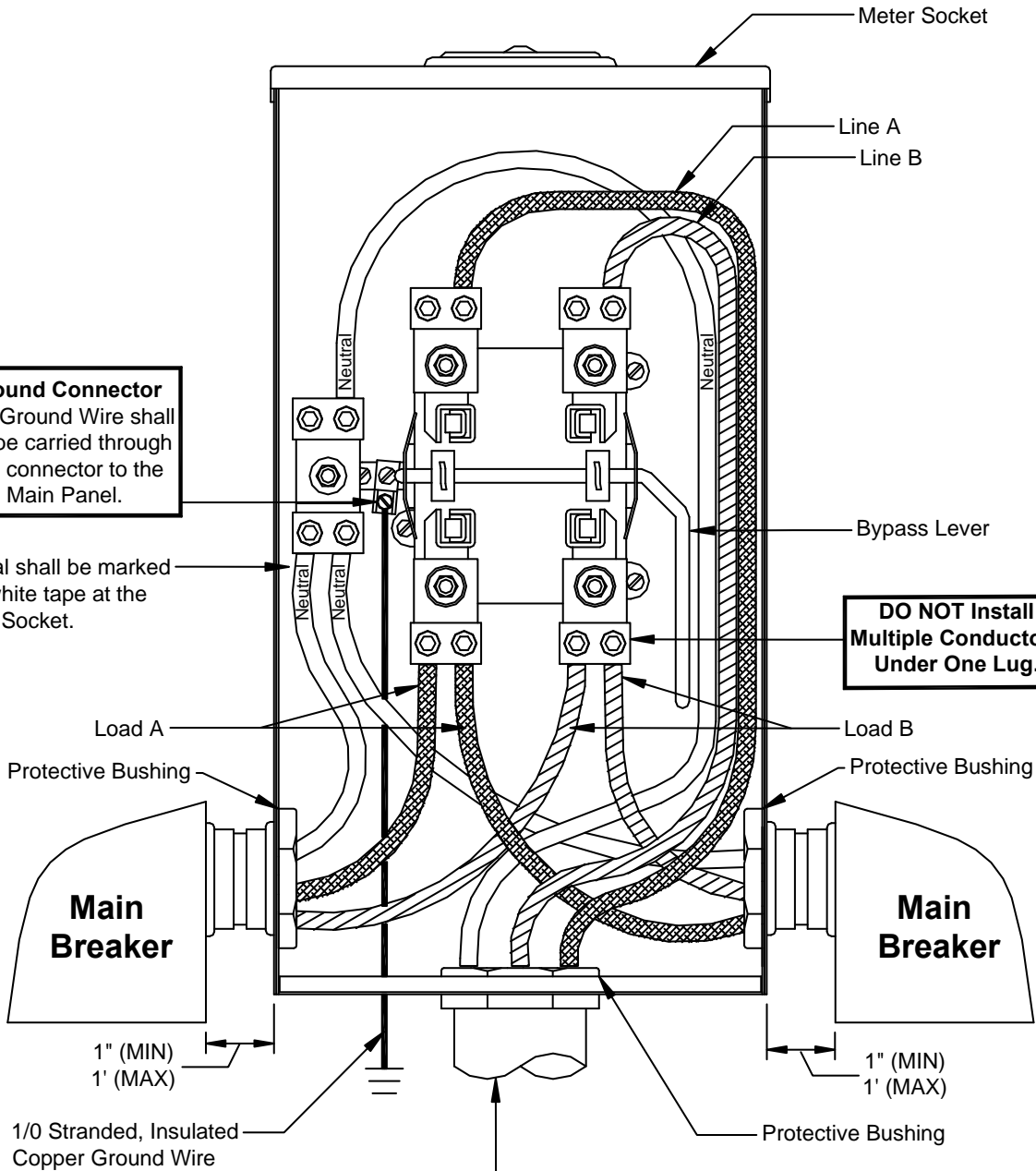

Figure 45: 200 Amp Combination Meter Socket, Network (120/208) Underground Service

Ground Connector
The Ground Wire shall not be carried through this connector to the Main Panel.

Neutral shall be marked with white tape at the Meter Socket.

DO NOT Install Multiple Conductors Under One Lug.



1/0 Stranded, Insulated Copper Ground Wire

3" conduit furnished and installed by Customer in the center position only.

Protective Bushing is required where indicated for PVC or if Rigid Steel is used, a Grounding Bushing is required.

All Equipment Furnished & Installed By Customer Unless Otherwise Noted.

08/05/19	KMH
01/22/09	SDS
07/17/06	SDS
06/17/05	SDS
07/01/97	AMA
REVISIONS	



320 Amp Meter Socket, Underground Service	
DRAWN: LU	DWG. NO. G18A2134
SCALE: NTS	FIGURE 46
DATE:01/01/95	

Figure 46: 320 Amp Meter Socket, Underground Service

Note:
This application for
120/208v, 3 wire service.

This wire must have white insulation and will be connected as shown. This wire will be provided and installed by the Customer on **Approved Meter Sockets**.

The Customer will provide and install the 5th lug on **Approved Meter Sockets**. For a list of these, refer to **Appendix A**.

Ground Connector
 The Ground Wire shall not be carried through this connector to the Main Panel.

Neutral shall be marked with white tape at the Meter Socket.

DO NOT install Multiple Conductors Under One Lug.

Load A

Load B

Protective Bushing

Protective Bushing

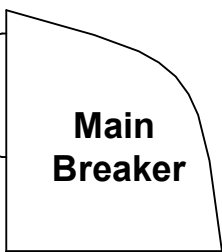
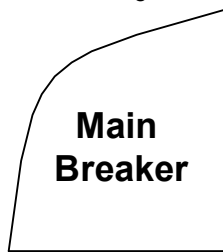

1" (MIN)
1' (MAX)

1" (MIN)
1' (MAX)

1/0 Stranded, Insulated Copper Ground Wire

3" conduit furnished and installed by Customer in the center position only.

Protective Bushing is required where indicated for PVC or if Rigid Steel is used, a Grounding Bushing is required.

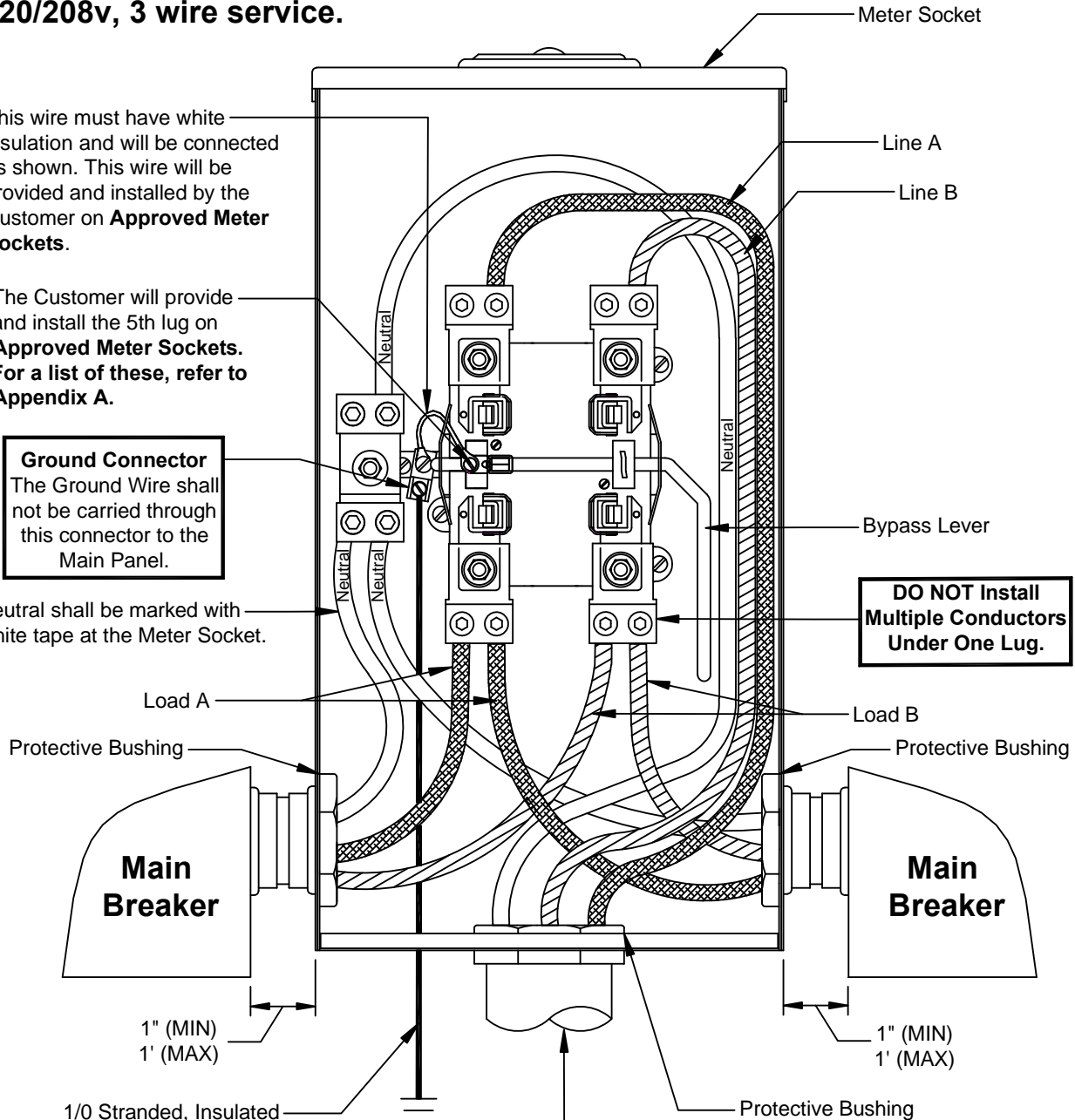

All Equipment Furnished & Installed
By Customer Unless Otherwise
Noted.

06/11/20 SMS
 REVISIONS



320 Amp Meter Socket, Network (120/208), Underground Service	
DRAWN: LU	DWG. NO. G18A2134A
SCALE: NTS	FIGURE 46A
DATE:08/14/19	

Figure 46A: 320 Amp Meter Socket, Network (120/208), Underground Service

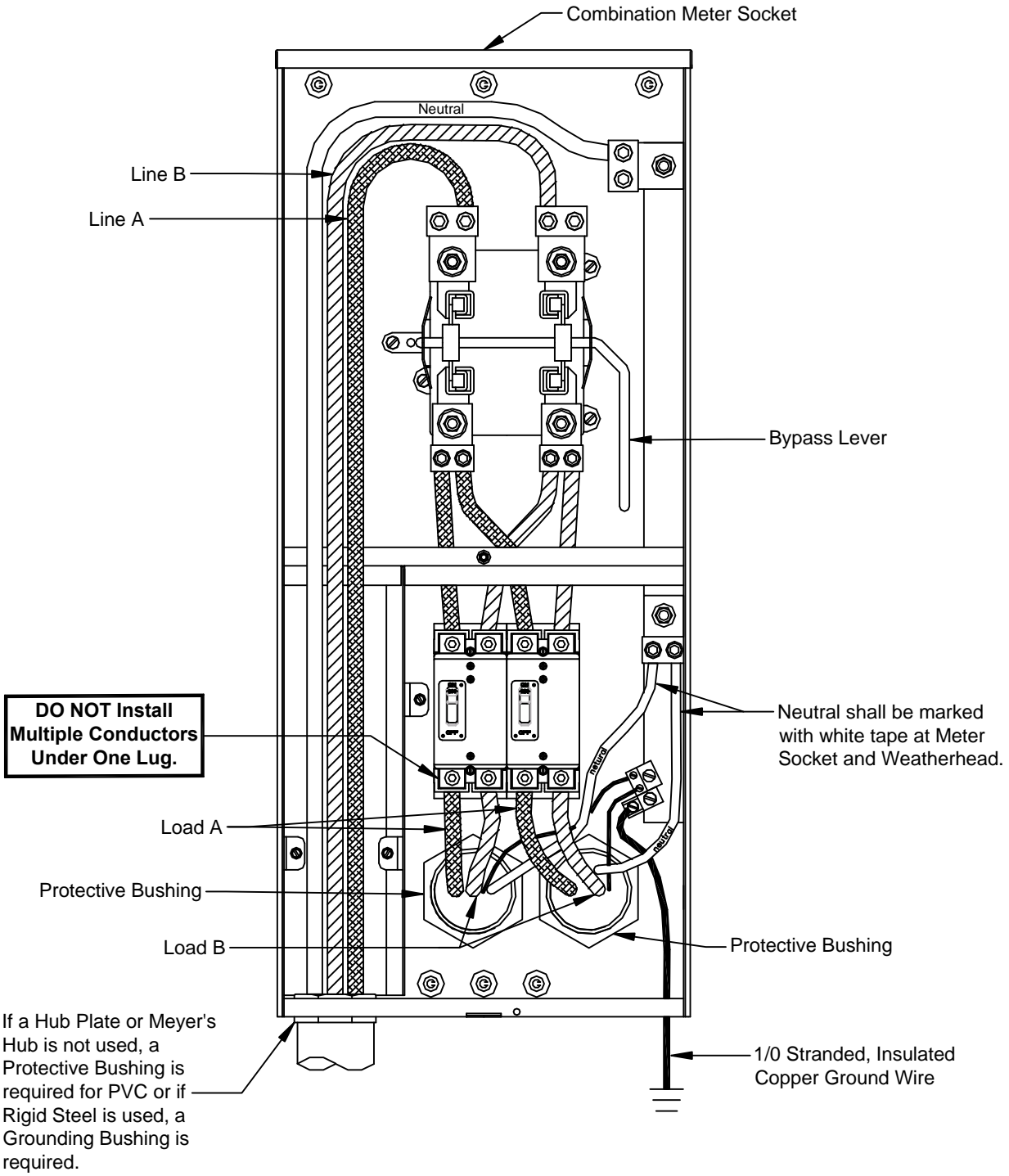

**All Equipment Furnished & Installed
By Customer Unless Otherwise
Noted.**

08/14/19 KMH
REVISIONS



320 Amp Combination Meter Socket Underground Service	
DRAWN: SDS	DWG. NO. G18A2135
SCALE: NTS	FIGURE 47
DATE:01/26/09	

Figure 47: 320 Amp Meter Socket, Network (120/208), Underground Service

Note:
This application for
120/208v, 3 wire service.

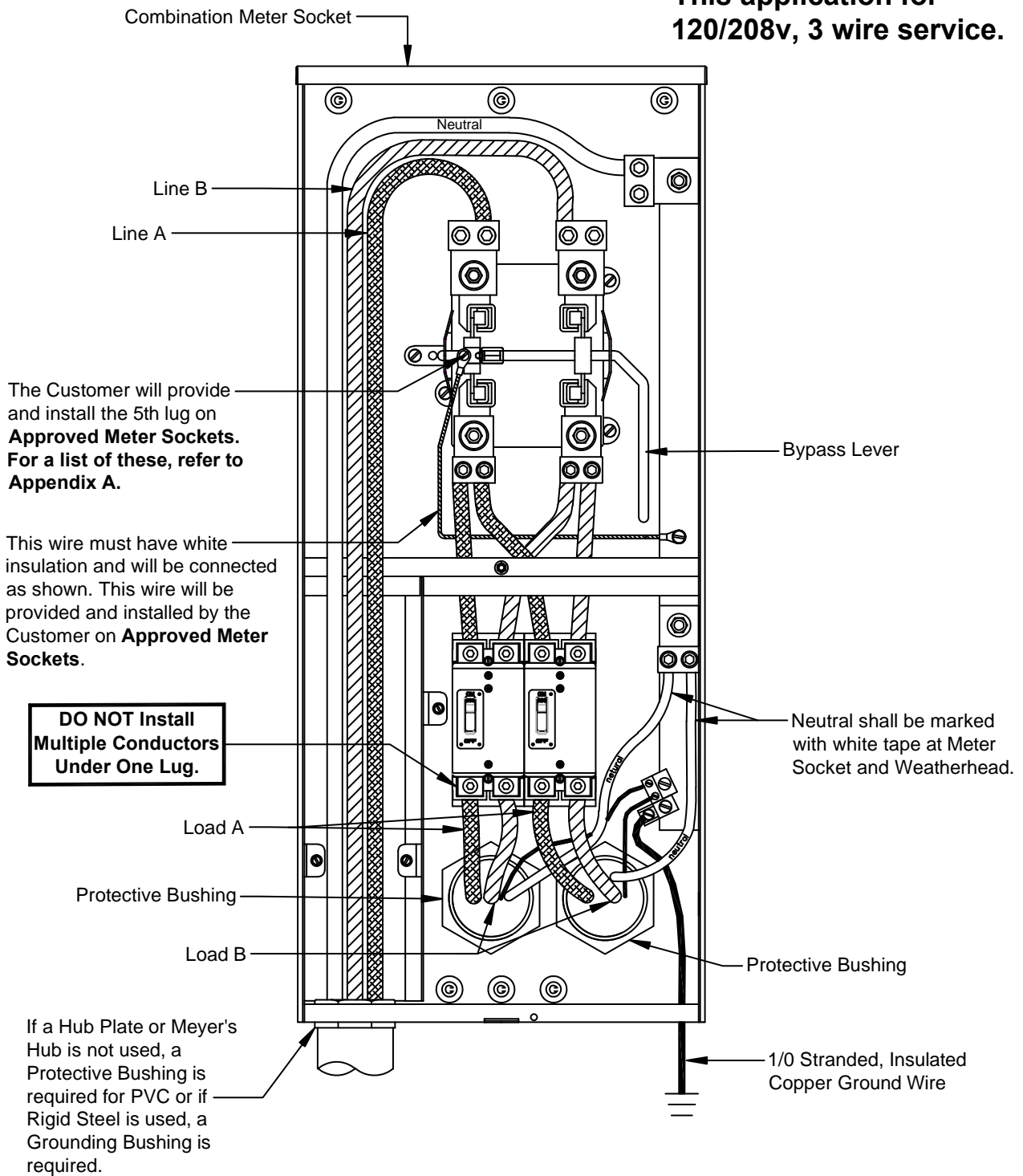

**All Equipment Furnished & Installed
 By Customer Unless Otherwise Noted.**

06/11/20 SMS
 08/14/19 KMH
 REVISIONS



320 Amp Combination Meter Socket, Network (120/208), Underground Service	
DRAWN: SDS	DWG. NO. G18A2135A
SCALE: NTS	FIGURE 47A
DATE: 01/26/09	

Figure 47A: 320 Amp Combination Meter Socket, Network (120/208), Underground Service

Caution!
Contact all utilities
before digging

Meter Pedestal leased for a fee.
 The company will own, install, and maintain the pedestal.

Service in Conduit

Breaker 120/240 or 120/208	Company Stock #
100 Amp	425092-100
200 Amp	425092-200

Note:
 This pedestal will accept GE Qline, Eaton - Cuttler Hammer Quicklag, Siemens/ITE - QP, Bryant - BR, and Square D - Homeline Breakers

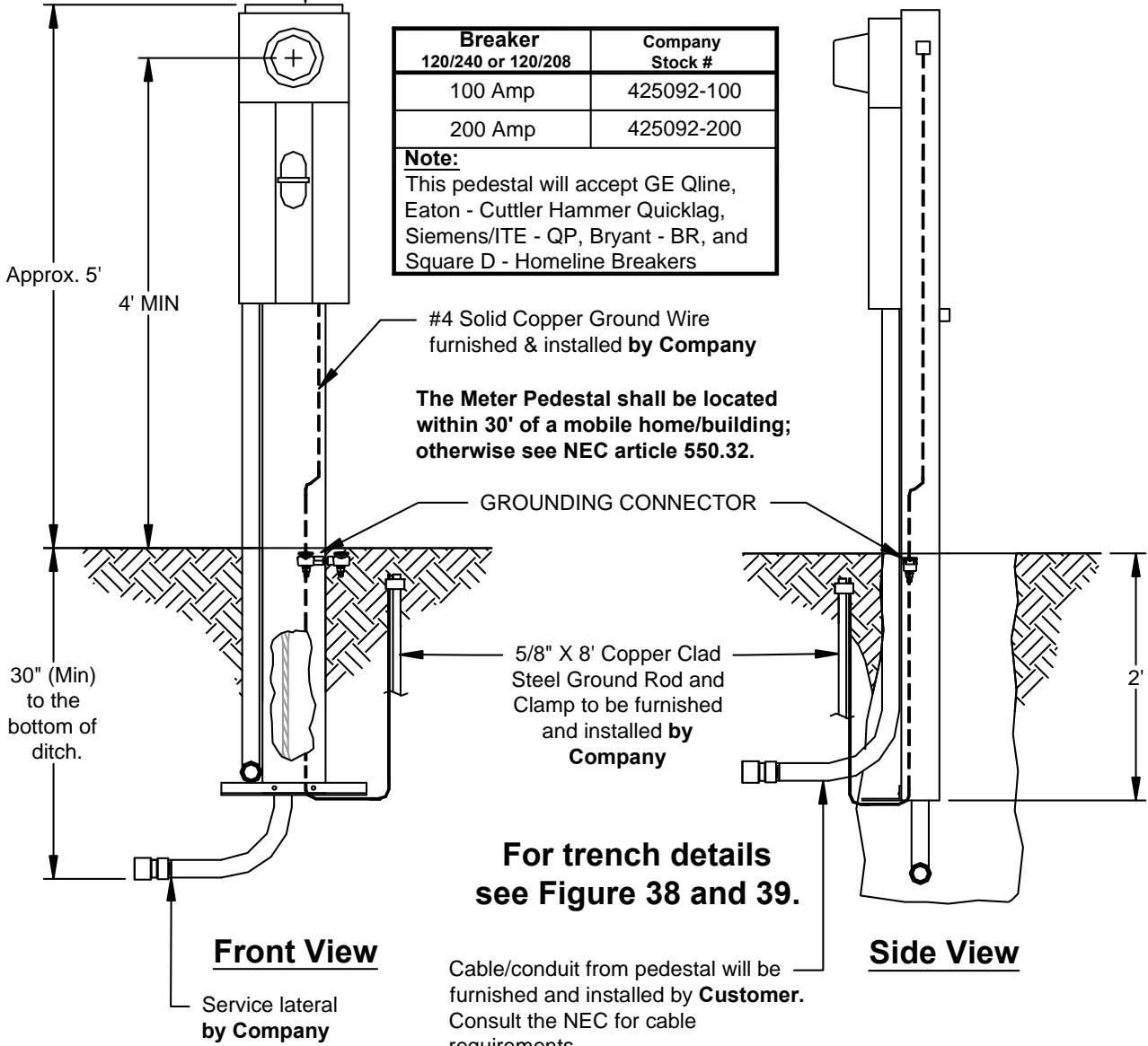

Mobile home parks can only be served 120/240 1Ø as per NEC 550.30.

08/26/19	KMH
07/15/06	SDS
01/01/97	AMA
REVISIONS	



Meter Pedestal	
DRAWN: LU	DWG. NO. G18A2136
SCALE: NTS	FIGURE 48
DATE:01/01/96	

Figure 48: Meter Pedestal

7.3 400 AMP TO 800 AMP CT METERING, SINGLE PHASE UNDERGROUND SERVICE

A. General Notes:

1. This arrangement may be utilized for services equal and above 400 amps and less than or equal to 800 amps.
2. The disconnection method may be composed of multiple disconnects to make up the full 800 amp capacity of the service as long as there are not more than 6. If one disconnect is used and it is greater than 400 amps, it may be located on the interior of the building unless the authority having jurisdiction dictates otherwise. Disconnects of 400 amps and below will be located on the exterior of the building. **Please note that in all case, the disconnects making up this service will be at the same location.**
3. The service lateral conductors and meter are furnished and installed by the Company. Customer will provide approximate final grade level within six inches (6") prior to service lateral installation.
4. The current transformers (CT's) are furnished and installed by the Company. The Customer shall provide and install the CT/connection cabinet.
 - a. **See Appendix A for list of approved CT/connection cabinets.**
5. The meter socket shall be purchased from the Company and installed by the Customer. The Location of this CT Cabinet and Meter will be determined by LU.
6. The metering control cable is furnished and installed by the Company.
7. The metering equipment should be "readily accessible" (see definitions). The Company requires a level and unobstructed work space of 78 inches tall, 18 inches on either side, and 48 inches in front of the metering equipment. Prior approval is required for placement of the metering equipment in alleyways or areas where it may be subjected to damage.

B. Mounting:

1. Meter socket, ground wire, CT/connection cabinet, and conduits for service lateral and metering control cable shall be surface mounted and securely fastened to the structure. The meter socket shall be installed in a level and plumb position. **Flush mounted or recessed metering equipment and service lateral conduit embedded in a wall will not be permitted.**
2. Where the exterior wall is other than brick or concrete blocks, a support frame shall be installed behind the exterior wall to provide a solid mounting surface for the metering equipment.
3. Meter sockets, metering cabinets, and conduit straps shall be installed with the following:
 - a. Lead anchors or double helix concrete screws shall be used with brick or solid concrete surfaces.
 - b. Toggle bolts shall be used with other masonry siding.
 - c. Wood screws shall be used with solid wood surfaces.
 - d. All mounting hardware shall be minimum #12(1/4") corrosion resistant screws.
 - e. A minimum of 4 fasteners shall be used to install any socket or cabinet unless specifically stated otherwise.

4. An intersystem bonding termination bar shall be installed to facilitate the connection of other utility's ground to a common ground. The location of this device shall be located directly below the meter socket or meter combination socket.

a. See Appendix A for list of approved intersystem bonding termination bars.

5. If PVC is used for the conduit attached to the meter socket, the rigid metal elbow shall be grounded/bonded to the service ground rod unless it is isolated from possible contact by a minimum cover of 18 inches to any part of the elbow as per NEC Article 250.80, Service Raceways and Enclosures.

a. See Appendix A for list of approved grounding clamps.

6. Conduits shall be furnished and installed by Customer.

C. Connections:

All connections inside the CT/connection cabinet shall be made by Company. The Company shall provide the connectors.

D. Conductor Marking:

All neutral conductors shall be clearly marked with white tape at the point of delivery.

THIS PAGE INTENTIONALLY LEFT BLANK

One inch (1") conduit furnished and installed **by Customer** no longer than 50 feet from the Meter Socket to Current Transformer/Connection Cabinet.

Enclosure Latching Handle that provides for three point latching on the cabinet and accommodates a 3/8" shackle Company padlock.

Connectors and current transformers provided and installed **by Company**.

Current transformer/connection cabinet with 3/4" exterior plywood panel furnished and installed **by customer**. See previous page for approved supplier detail.

Caution!
Contact all utilities before digging

Meter socket purchased from the company for a fee & installed **by customer**.

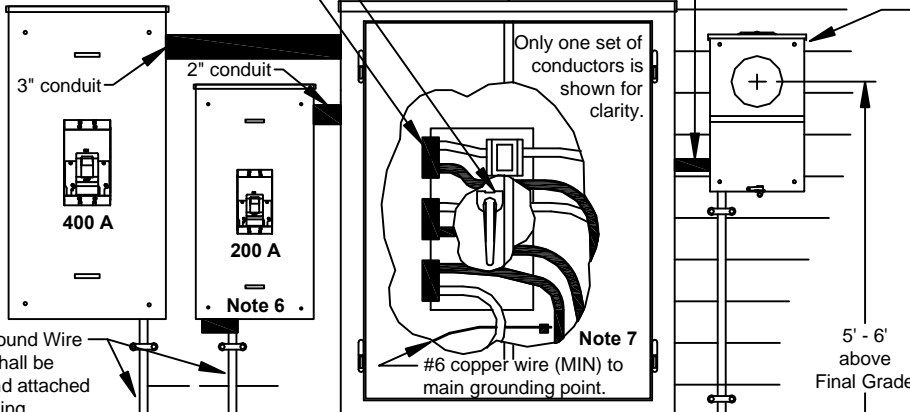

NOTE:
Customer's Service Entrance Conductors shall extend 48 inches inside cabinet

Copper Ground Wire
This wire shall be external and attached to the building. Follow NEC Guidelines if Conduit is used. Service Equipment Ground Electrode System as per NEC furnished and installed **by Customer**.

Final Grade

30" (MIN) to the bottom of ditch

All Grounding Systems shall be bonded together.

The number of 3" conduits will vary depending on the service requirement.

The conduit shall rest on the bottom of the trench and will point toward the service source. See Figure 38 & 39.

NOTES:

1. A 1/4" synthetic pull rope must be installed in the conduit.
2. A conduit vent may be needed depending on the service arrangement and terrain.
3. Line of Sight installation is required. See Definitions.
4. If the service route is longer than 100', contact Liberty Utilities for conduit requirements.
5. A metal elbow that is installed in an underground installation of rigid nonmetallic conduit and is isolated from possible contact by a minimum cover of 18 inches to any part of the elbow shall not be required to be grounded as per NEC Article 250.80, Service Raceways and Enclosures.
6. Either install a #6 copper wire (Minimum) from the same connection point as the main Copper Ground Wire connection in the Service Disconnect or from the ground rod to **Intersystem Ground Connector**.
7. Equipment Ground Lug - **NO NEUTRAL TO GROUND BOND IN THE CT/CONNECTION CABINET**.
8. Slip-Joint may be used if permissible by local jurisdiction.

24" (MIN) 36" (MAX)

Two Hole Conduit Strap or Conduit Hanger (Minerallac)

#4 CU

1/0 CU

5/8" X 8' Copper Clad Steel Ground Rod and Clamp

#6 copper wire (minimum) connected to 5/8" x 8' Copper Clad Steel Ground Rod. This wire shall be external and attached to the building. Follow NEC Guidelines if conduit is used. The Customer may use the Meter Socket Ground Rod for the Service Equipment Ground as directed by the NEC, but the Service Equipment Ground Conductor shall **NOT** pass through the Meter Socket.

3" Rigid steel conduit is preferred but 3" Sch 80 electrical grade PVC may be used.

Ground elbow with grounding clamp. See Note 5.

3" Galvanized Rigid Steel Elbow with a minimum radius of 13"

!!!! WARNING !!!!

If this elbow is not supported or if the soil under it is not well compacted, the conduit may pull out of the CT Cabinet resulting in a possible failure of the service.



This denotes undisturbed earth.

All Equipment Furnished & Installed By Customer Unless Otherwise Noted.

07/08/19	KMH
07/06/10	SDS
03/18/10	SDS
04/01/09	SDS
07/15/06	SDS
05/17/05	SDS
01/01/97	AMA
REVISIONS	



400 Amp to 800 Amp Current Transformer Metering Underground Service	
DRAWN: LU	DWG. NO. G18A2137
SCALE: NTS	FIGURE 49
DATE:01/01/95	

Figure 49: 400 Amp to 800 Amp CT Metering, Underground Service

7.4 MULTIPLE METERS, SINGLE PHASE UNDERGROUND SERVICE

A. General Notes:

1. If more than six meters are required, consult the Company for approval of equipment prior to purchase.
2. Service entrance conductors, 5/8" x 8' copper clad steel ground rod, ground rod clamp, ground wire, conduit, conduit straps, lock nuts, bushings, meter socket assembly, hub closing plate, and miscellaneous mounting hardware furnished and installed by the Customer.
3. Meters, service connectors, and service lateral conductors furnished and installed by Company.
4. The meter socket assembly should be "readily accessible" (see definitions). The Company requires a level and unobstructed work space of 78 inches tall, 18 inches on either side, and 48 inches in front of the meter socket assembly. Prior approval is required for placement of the meter socket assembly in alleyways or areas where it may be subjected to damage.
5. The 100 Amp and 200 Amp meter sockets shall meet the following specifications:
 - a. The latest revision of U.L. 414 and ANSI C12.7 Standards.
 - b. Must be U.L. listed.
 - c. Must have grounding connector for triplex.
 - d. Lug size – 2/0 minimum.
 - e. On 120/208v services, the customer must provide the meter socket with 5th lug installed in the 9 o'clock position.
 - f. **See Appendix A for list of approved meter sockets.**

B. Mounting:

1. Meter socket assembly, ground wire, and conduit shall be surface mounted and securely fastened to the structure. The meter socket assembly shall be installed in a level and plumb position. **Flush mounted or recessed metering equipment and service lateral conduit embedded in a wall will not be permitted.**
2. Where the exterior wall is other than brick or concrete blocks, a support frame shall be installed behind the exterior wall to provide a solid mounting surface for the meter socket.
3. Meter sockets, metering cabinets, and conduit straps shall be installed with the following:
 - a. Lead anchors or double helix concrete screws shall be used with brick or solid concrete surfaces.
 - b. Toggle bolts shall be used with other masonry siding.
 - c. Wood screws shall be used with solid wood surfaces.
 - d. All mounting hardware shall be minimum #12(1/4") corrosion resistant screws.
 - e. A minimum of 4 fasteners shall be used to install any socket or cabinet unless specifically stated otherwise.

4. An intersystem bonding termination bar shall be installed to facilitate the connection of other utility's ground to a common ground. The location of this device shall be located directly below the meter socket or meter combination socket.

a. See Appendix A for list of approved intersystem bonding termination bars.

5. If PVC is used for the conduit attached to the meter socket, the rigid metal elbow shall be grounded/bonded to the service ground rod unless it is isolated from possible contact by a minimum cover of 18 inches to any part of the elbow as per NEC Article 250.80, Service Raceways and Enclosures.

a. See Appendix A for list of approved grounding clamps.

6. Conduit ends shall be equipped with a proper bushing to protect the conductors.

C. Connections:

1. The Customer is responsible for termination of the incoming wiring if the wire terminates in a main breaker or fuse holder. The Company will terminate the incoming wire if it terminates on bus bar terminals. The main breaker will be removed when the service wire is being pulled by the Company.
2. Do not score load wire when removing insulation.
3. The Customer shall use wire brush or sandpaper to clean all conductors, apply a non-grit type inhibitor and tighten to manufacturer's specifications.

D. Meter Socket Marking:

1. **Before the meters are installed, each socket position and corresponding building unit, i.e. apt number or letter, Suite number or letter, tenant number or letter, or physical address served shall be accurately, clearly, and permanently labeled with an engraved plaque. These shall be screwed, bolted or riveted externally to the equipment. See figures for proper location. If the equipment is marked incorrectly, the customer shall be responsible for all costs incurred by LU for correcting the meter socket identification. Please note that marker ink or adhesive labels are examples of non-permanent labeling.**
2. **Letters or numbers on the engraved plaque shall be a minimum of one (1) inch in height of contrasting color, i.e., black and white, red and green, orange and blue, etc.**

E. Conductor Marking:

All neutral conductors shall be clearly marked with white tape at the meter socket assembly.

Caution!
Contact all utilities
before digging

- * Provision for Company seal and Company padlock with 3/8" shackle
- ☒☒☒ Marking as required in Section 7.4.D
- ✓ Unit disconnection means with lock-off provisions must accept Company padlock with 3/8" shackle

The maximum amperage Meter Socket allowed in this configuration is 200A.

These connectors shall accept 1-350 MCM AL

The maximum amperage Meter Socket allowed in this configuration is 200A.

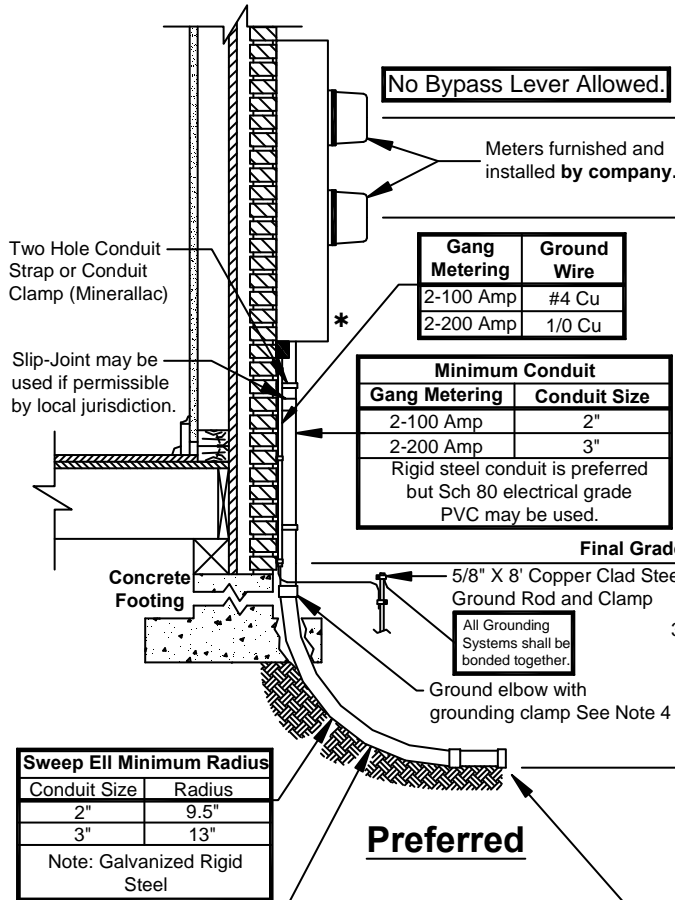

Install Intersystem Ground Connector.

Slip-Joint may be used if permissible by local jurisdiction.

No Bypass Lever Allowed.

Meters furnished and installed by company.

Gang Metering	Ground Wire
2-100 Amp	#4 Cu
2-200 Amp	1/0 Cu

Minimum Conduit	
Gang Metering	Conduit Size
2-100 Amp	2"
2-200 Amp	3"

Rigid steel conduit is preferred but Sch 80 electrical grade PVC may be used.

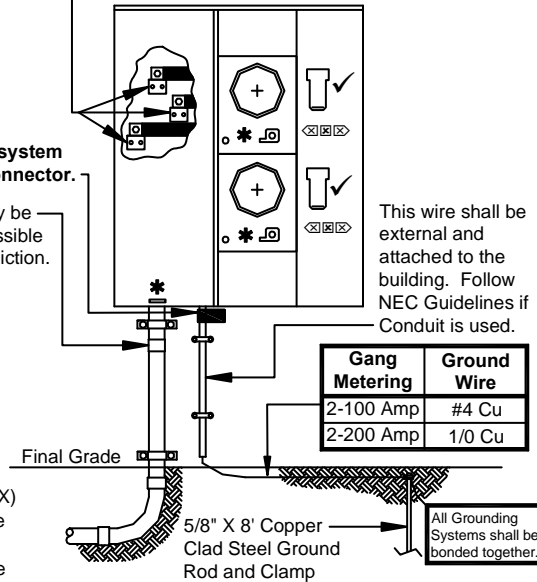

This wire shall be external and attached to the building. Follow NEC Guidelines if Conduit is used.

Gang Metering	Ground Wire
2-100 Amp	#4 Cu
2-200 Amp	1/0 Cu

All Grounding Systems shall be bonded together.

Sweep Ell Minimum Radius	
Conduit Size	Radius
2"	9.5"
3"	13"

Note: Galvanized Rigid Steel

Preferred

Alternate

!!!! WARNING !!!!

If this elbow is not supported or if the soil under it is not well compacted, the conduit may pull out of the Meter Pack resulting in a possible failure of the service.

This denotes undisturbed earth.

NOTES:

1. A Conduit Vent may be needed depending on the service arrangement and terrain.
2. Line of Sight installation is required. See Definitions.
3. If the service route is longer than 100', contact the Company for conduit requirements.
4. A metal elbow that is installed in an underground installation of rigid nonmetallic conduit and isolated from possible contact by a minimum cover of 18 inches to any part of the elbow shall not be required to be grounded as per NEC Article 250.80, Service Raceways and Enclosures.
5. A 1/4" synthetic pull rope must be installed in the conduit.

All Equipment Furnished & Installed By Customer Unless Otherwise Noted.

08/27/19	KMH
07/14/09	SDS
07/15/05	SDS
05/17/05	SDS
REVISIONS	

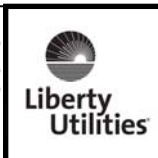

Wiring of two Meters, Underground Service	
DRAWN: LU	DWG. NO. G18A2138
SCALE: NTS	FIGURE 50
DATE:01/01/95	

Figure 50: Wiring of two Meters, Underground Service

* Provision for company seal and company padlock with 3/8" shackle

☒☒☒ Marking as required in Section 7.4.D

✓ Unit disconnection means with lock-off provisions must accept company padlock with 3/8" shackle

No Bypass Lever Allowed.

The maximum amperage Meter Socket allowed in this configuration is 200A.

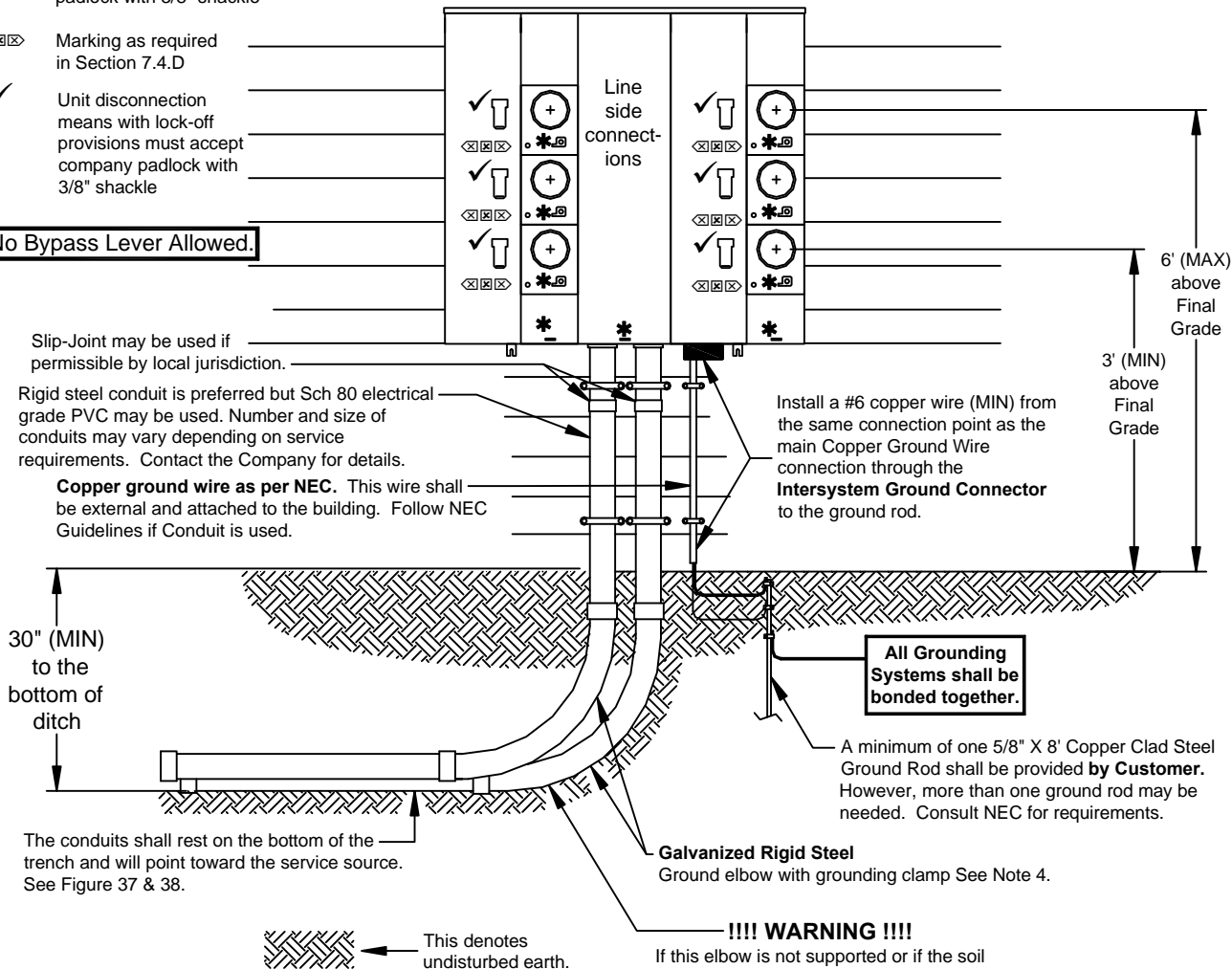

The number, type, and size of conduits will vary with each installation. Contact the Company for more information.

**Caution!
Contact all utilities before digging**

NOTES:

1. A Conduit Vent may be needed depending on the service arrangement and terrain.
2. Line of Sight installation is required. See Definitions.
3. If the service route is longer than 100', contact the Company for conduit requirements.
4. A metal elbow that is installed in an underground installation of rigid nonmetallic conduit and isolated from possible contact by a minimum cover of 18 inches to any part of the elbow shall not be required to be grounded as per NEC Article 250.80, Service Raceways and Enclosures.
5. A 1/4" synthetic pull rope must be installed in the conduit.

All Equipment Furnished & Installed By Customer Unless Otherwise Noted.

08/14/19	KMH
07/14/09	SDS
07/15/06	SDS
05/17/05	SDS
07/01/97	SDS
REVISIONS	



Three to six Meters, Underground Service	
DRAWN: LU	DWG. NO. G18A2138
SCALE: NTS	FIGURE 51
DATE:01/01/95	

Figure 51: Three to Six Meters, Underground Service

7.5 200 AMP(208Y/120V or 240Δ/120V only) THREE PHASE UNDERGROUND SERVICE

A. General Notes:

1. Service entrance conductors, 5/8" x 8' copper clad steel ground rod, ground rod clamp, ground wire, conduit, conduit straps, lock nuts, bushings, meter socket, main disconnect and miscellaneous mounting hardware furnished and installed by Customer.
2. Meter and service lateral conductors furnished and installed by Company.
3. The meter socket should be "readily accessible" (see definitions). The Company requires a level and unobstructed work space of 78 inches tall, 18 inches on either side, and 48 inches in front of the meter socket. Prior approval is required for placement of the meter socket in alleyways or areas where it may be subjected to damage.
4. **The 200 amp meter socket closing plate shall be purchased from the Company and installed by the Customer.**
5. Conduit system shall be installed as per Figure 38 & 39.

B. Mounting:

1. Meter socket, ground wire, and conduit shall be surface mounted and securely fastened to the exterior structure. The meter socket shall be installed in a level and plumb position. **Flush mounted metering or recessed equipment and service lateral conduit embedded in a wall will not be permitted.**
2. Where the exterior wall is other than brick or concrete blocks, a support frame shall be installed behind the exterior wall to provide a solid mounting surface for the meter socket.
3. Meter sockets, metering cabinets, and conduit straps shall be installed with the following:
 - a. Lead anchors or double helix concrete screws shall be used with brick or solid concrete surfaces.
 - b. Toggle bolts shall be used with other masonry siding.
 - c. Wood screws shall be used with solid wood surfaces.
 - d. All mounting hardware shall be minimum #12(1/4") corrosion resistant screws.
 - e. A minimum of 4 fasteners shall be used to install any socket or cabinet unless specifically stated otherwise.
4. An intersystem bonding termination bar shall be installed to facilitate the connection of other utility's ground to a common ground. The location of this device shall be located directly below the meter socket or meter combination socket.
 - a. **See Appendix A for list of approved intersystem bonding termination bars.**
5. If PVC is used for the conduit attached to the meter socket, the rigid metal elbow shall be grounded/bonded to the service ground rod unless it is isolated from possible contact by a minimum cover of 18 inches to any part of the elbow as per NEC Article 250.80, Service Raceways and Enclosures.
 - a. **See Appendix A for list of approved grounding clamps.**
6. For 200 amp service, a minimum of three inch (3") galvanized rigid steel or electrical grade Schedule 80 PVC conduit shall be furnished and installed by Customer as shown in Figure 52.

C. Connections:

1. Do not score load wire when removing insulation.
2. The Customer shall use wire brush or sandpaper to clean all conductors, apply a non-grit type inhibitor and tighten to manufacturer's specifications.

D. Conductor marking

1. All neutral conductors shall be clearly marked with white tape at the point of delivery and at the meter socket.
2. The power leg of each 240/120 volt, three-phase, four-wire delta service shall be clearly marked with orange tape at the point of delivery and at the meter socket (refer to Figure 54).

E. Phase Rotation

On three-phase installations to insure proper equipment operation, the Customer is responsible for verifying phase rotation at the time of service connection.

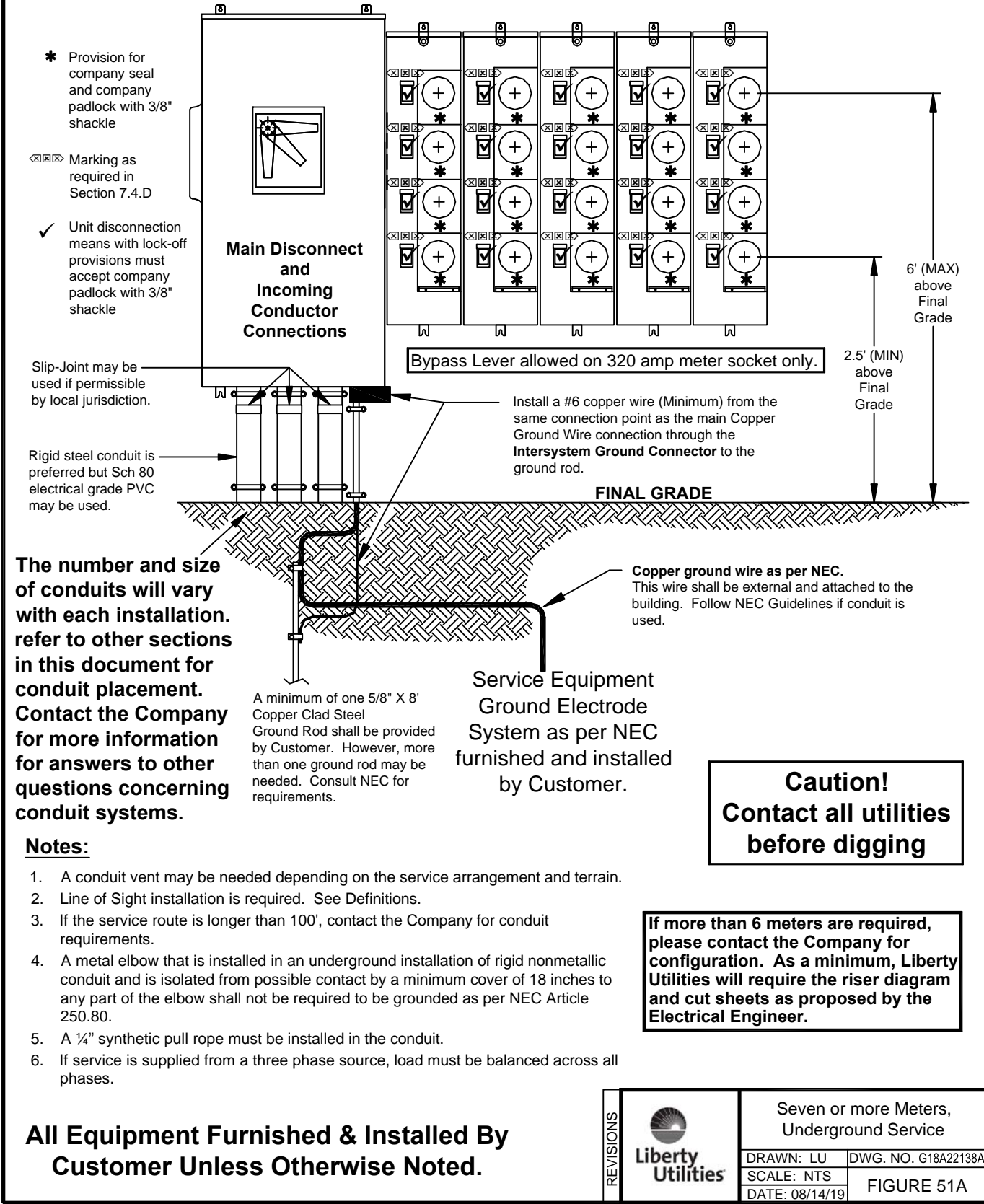
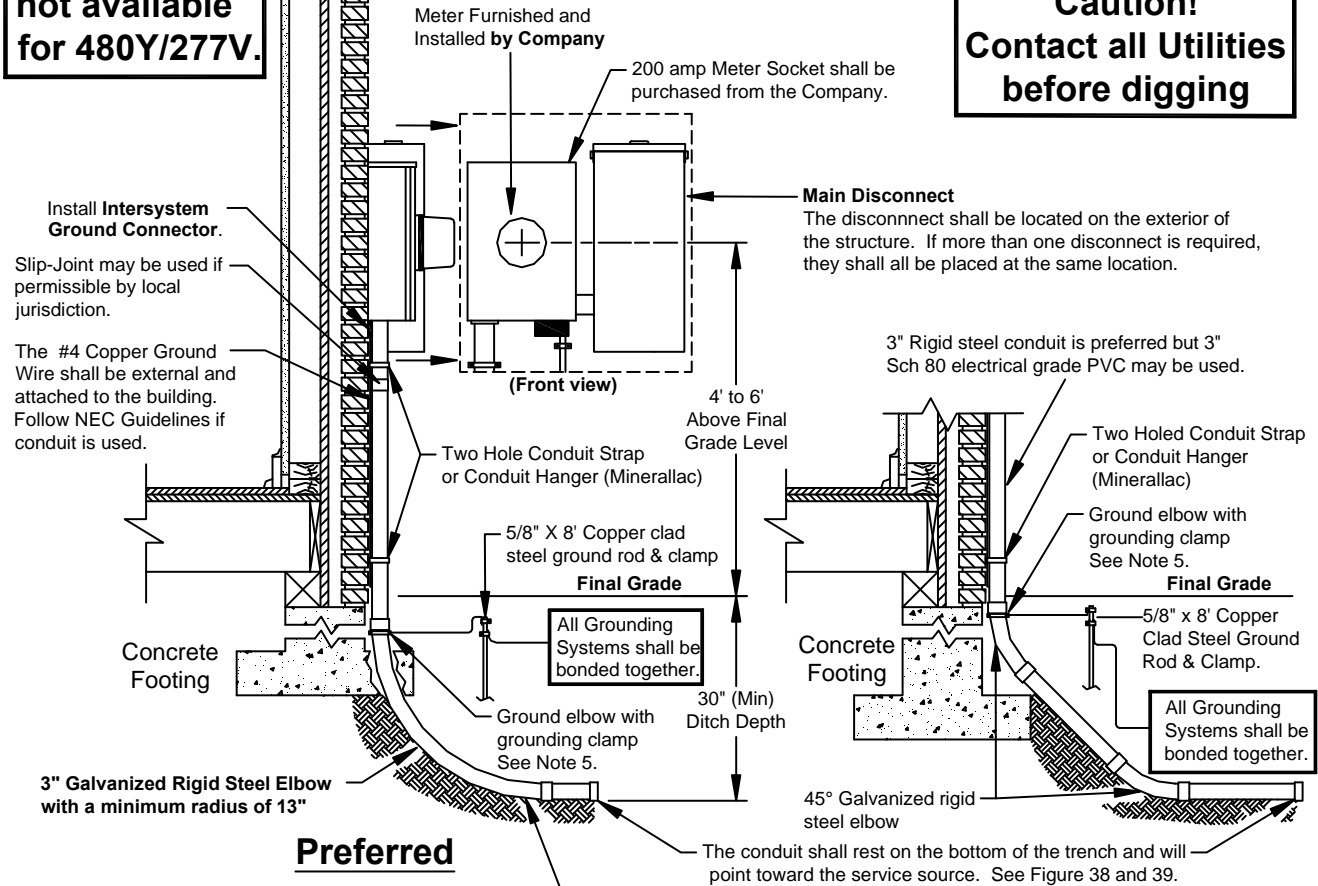

Figure 51A: Seven or more Meters, Underground Service

Ground Rod and Wire **MUST** be Installed and Ground Wire **MUST** be attached to the structure before Service will be Connected.

Note:
This service not available for 480Y/277V.

Caution!
Contact all Utilities before digging



Preferred

Alternate

!!! WARNING !!!
If this elbow is not supported or if the soil under it is not well compacted, the conduit may pull out of the meter socket resulting in a possible failure of the service.

This denotes undisturbed earth.

Notes:

1. If a conduit reducer is used, it must be located immediately below the Meter Socket.
2. A conduit vent may be needed depending on the service arrangement and terrain.
3. Line of Sight installation is required. See Definitions.
4. If the service route is longer than 100', contact the Company for conduit requirements.
5. A metal elbow that is installed in an underground installation of rigid nonmetallic conduit and is isolated from possible contact by a minimum cover of 18 inches to any part of the elbow shall not be required to be grounded as per NEC Article 250.80, Service Raceways and Enclosures.
6. A 1/4" synthetic pull rope must be installed in the conduit.

All Equipment Furnished & Installed By Customer Unless Otherwise Noted.

08/16/19 KMH 07/10/09 SDS 07/15/06 SDS REVISIONS		200 Amp Underground Service	
		DRAWN: LU	DWG. NO. G18A2140
		SCALE: NTS	FIGURE 52
		DATE:01/01/95	

Figure 52: 200 Amp, Underground Service

Note:
This service not available for 480Y/277V.

Meter Socket shall be purchased from Company and installed by the Customer.

Service Entrance Conductors furnished and installed by Company.

Ground Connector
 The Ground Wire shall not be carried through this connector to the Main Panel.

Plastic protective shield for the Meter Socket must be in place. It has not been shown so that the connections can be depicted clearly.

DO NOT Install Multiple Conductors Under One Lug.

1" (MIN)
 1' (MAX)

Main Breaker

Load Conductors

Main Breaker

Service Size	Ground Wire
200 Amp	#4 Cu.

Protective Bushing is required for PVC or if Rigid Steel is used, a grounding bushing is required.

1" (MIN)
 1' (MAX)

Note:

1. On delta installation, B phase position must be the Power (High) Leg (See Figure 54)
2. **No center installation of conduit allowed.** Conduit furnished and installed by Customer in the left or right bottom knockout provided.

All Equipment Furnished & Installed By Customer Unless Otherwise Noted.

08/14/19 KMH 07/15/09 SDS 07/15/06 SDS REVISIONS		200 Amp Meter Socket, Underground Service	
		DRAWN: LU	DWG. NO. G18A2141
		SCALE: NTS	FIGURE 53
		DATE:01/01/95	

Figure 53: 100/200 Amp Meter Socket, Underground Service

Power (High) Leg MUST be in the center lug as facing the Meter Socket for correct meter registration. Mark this phase with orange tape.

Delta Connected Transformer Bank This is for Pole Mounted Transformers only with an underground service. This service is limited to 200 amp Capacity.

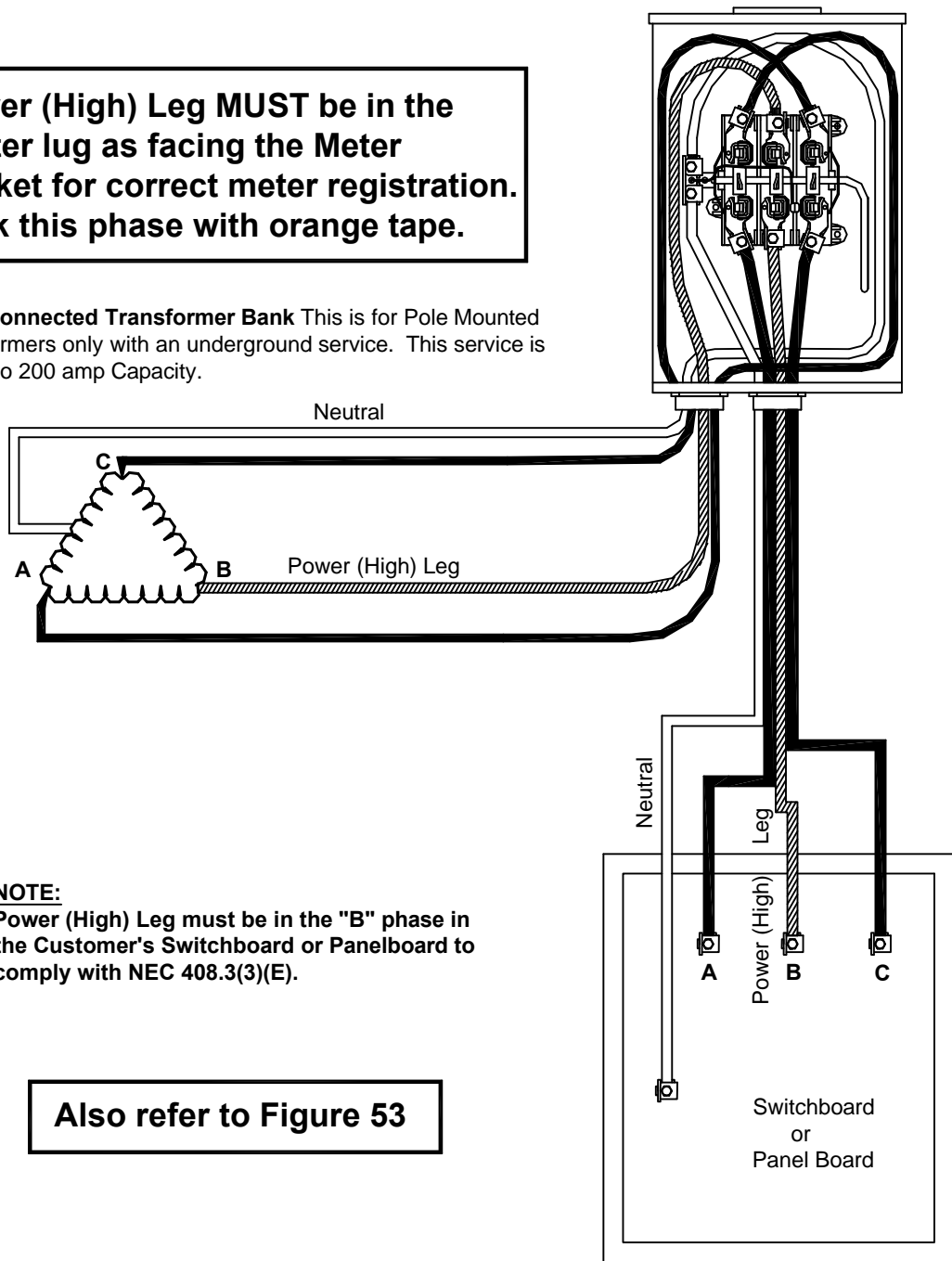

NOTE:
Power (High) Leg must be in the "B" phase in the Customer's Switchboard or Panelboard to comply with NEC 408.3(3)(E).

Also refer to Figure 53

08/16/19 KMH 07/15/06 SDS REVISIONS		Power Leg Connection on Three Phase, Four Wire, Delta Connected Systems	
		DRAWN: LU	DWG. NO. G18A2142
		SCALE: NTS	FIGURE 54
		DATE: 01/01/96	

Figure 54: Power Leg Connection on 3 Phase, 4 Wire Delta Connected Systems

7.6 200 AMP TO 1200 AMP CT METERING, THREE PHASE UNDERGROUND SERVICE

A. General Notes:

1. This arrangement may be utilized for services from 200 amps and less than or equal to 1200 amps. **For services greater than 1200 amps, contact the Company.**
2. The disconnection method may be composed of multiple disconnects to make up the full 1200 amp capacity of the service as long as there are not more than 6. If one disconnect is used and it is greater than 400 amps, it may be located on the interior of the building unless the authority having jurisdiction dictates otherwise. Disconnects of 400 amps and below will be located on the exterior of the building. **Please note that in all cases, the disconnects making up this service will be at the same location.**
3. The service lateral conductors and meter are furnished and installed by the Company. Customer will provide approximate final grade level within six inches (6") prior to service lateral installation.
4. The current transformers (CT) are furnished and installed by the Company. The Customer shall provide and install the CT/connection cabinet.
 - a. **See Appendix A for list of approved CT/connections cabinets.**
5. The meter socket shall be purchased from the Company and installed by the Customer.
6. The metering control cable is furnished and installed by the Company.
7. The metering equipment should be "readily accessible" (see definitions). The Company requires a level and unobstructed work space of 78 inches tall, 18 inches on either side, and 48 inches in front of the metering equipment. Prior approval is required for placement of the metering equipment in alleyways or areas where it may be subjected to damage.

B. Mounting:

1. Metering equipment, ground wire, and conduits for service lateral and metering control cable shall be surface mounted and securely fastened to the structure. The meter equipment shall be installed in a level and plumb position. **Flush mounted or recessed metering equipment and service lateral conduit embedded in a wall will not be permitted.**
2. Where the exterior wall is other than brick or concrete blocks, a support frame shall be installed behind the exterior wall to provide a solid mounting surface for the metering equipment.
3. Meter sockets, metering cabinets, and conduit straps shall be installed with the following:
 - a. Lead anchors or double helix concrete screws shall be used with brick or solid concrete surfaces.
 - b. Toggle bolts shall be used with other masonry siding.
 - c. Wood screws shall be used with solid wood surfaces.
 - d. All mounting hardware shall be minimum #12(1/4") corrosion resistant screws.
 - e. A minimum of 4 fasteners shall be used to install any socket or cabinet unless specifically stated otherwise.

4. An intersystem bonding termination bar shall be installed to facilitate the connection of other utility's ground to a common ground. The location of this device shall be located directly below the meter socket or meter combination socket.

a. See Appendix A for list of approved intersystem bonding termination bars.

5. If PVC is used for the conduit attached to the meter socket, the rigid metal elbow shall be grounded/bonded to the service ground rod unless it is isolated from possible contact by a minimum cover of 18 inches to any part of the elbow as per NEC Article 250.80, Service Raceways and Enclosures.

a. See Appendix A for list of approved grounding clamps.

6. Conduits shall be furnished and installed by Customer.

C. Connections:

1. All connections inside the CT/connection cabinet shall be made by Company. The Company shall provide the connectors.
2. The point of delivery for this type of service is at the connectors in the CT/connection cabinet.

D. Conductor marking

All neutral conductors shall be clearly marked with white tape at the point of delivery.

E. Phase Rotation

On three-phase installations to insure proper equipment operation, the Customer is responsible for verifying phase rotation at the time of service connection.

THIS PAGE INTENTIONALLY LEFT BLANK

Caution!
Contact all utilities
before digging

NOTE:
Customer's
Service
Entrance
Conductors
shall extend
48 inches
inside cabinet

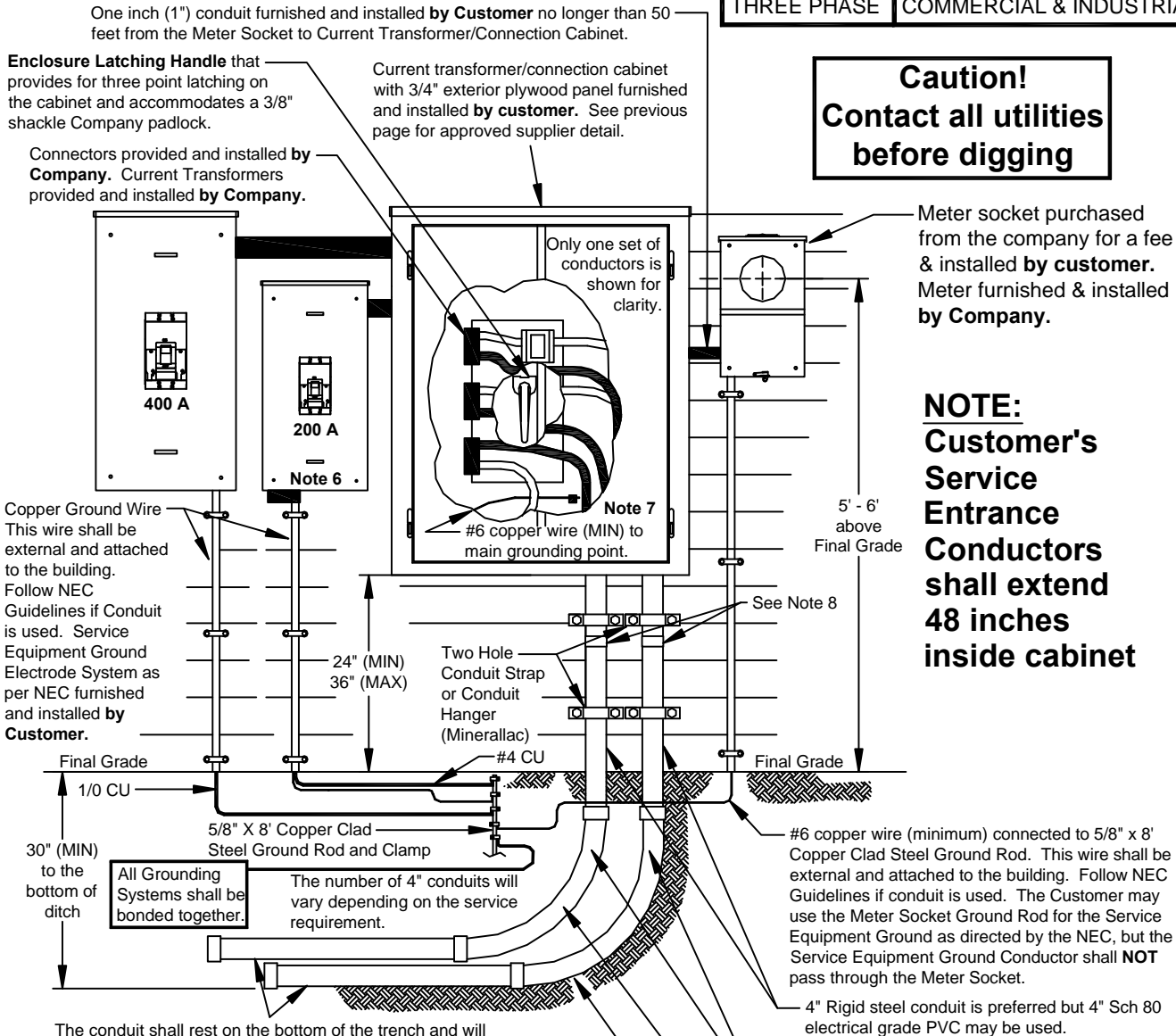

NOTES:

1. A 1/4" synthetic pull rope must be installed in the conduit.
2. A conduit vent may be needed depending on the service arrangement and terrain.
3. Line of Sight installation is required. See Definitions.
4. If the service route is longer than 100', contact Liberty Utilities for conduit requirements.
5. A metal elbow that is installed in an underground installation of rigid nonmetallic conduit and is isolated from possible contact by a minimum cover of 18 inches to any part of the elbow shall not be required to be grounded as per NEC Article 250.80, Service Raceways and Enclosures.
6. Either install a #6 copper wire (Minimum) from the same connection point as the main Copper Ground Wire connection in the Service Disconnect or from the ground rod to **Intersystem Ground Connector**.
7. Equipment Ground Lug - **NO NEUTRAL TO GROUND BOND IN THE CT/CONNECTION CABINET**.
8. Slip-Joint may be used if permissible by local jurisdiction.

Ground elbow with grounding clamp. See Note 5.

4" Galvanized Rigid Steel Elbow with a minimum radius of 16"

!!!! WARNING !!!!
If this elbow is not supported or if the soil under it is not well compacted, the conduit may pull out of the CT Cabinet resulting in a possible failure of the service.

All Equipment Furnished & Installed By Customer Unless Otherwise Noted.

08/28/19	KMH
07/06/10	SDS
03/18/10	SDS
04/01/09	SDS
07/15/06	SDS
05/17/05	SDS
01/01/97	AMA
REVISIONS	



200 Amp to 1200 Amp Current Transformer Metering Underground Service	
DRAWN: LU	DWG. NO. G18A2143
SCALE: NTS	FIGURE 55
DATE: 01/01/95	

Figure 55: 400 Amp to 1200 Amp CT Metering, Underground Service

7.7 MULTIPLE METERS (208Y/120V or 240 DELTA/120V only), THREE PHASE UNDERGROUND SERVICE

A. General Notes:

1. If more than six meters are required, consult the Company for approval of equipment prior to purchase.
2. Service entrance conductors, 5/8" x 8' copper clad steel ground rod, ground rod clamp, ground wire, conduit, conduit straps, lock nuts, bushings, meter socket assembly, hub closing plate, and miscellaneous mounting hardware furnished and installed by the Customer.
3. Meters and service lateral conductors furnished and installed by Company.
4. The meter socket assembly should be "readily accessible" (see definitions). The Company requires a level and unobstructed work space of 78 inches tall, 18 inches on either side, and 48 inches in front of the meter socket assembly. Prior approval is required for placement of the meter socket assembly in alleyways or areas where it may be subjected to damage.
5. If the Company is required to attach the service drop directly to the Customer's meter loop conduit, the Customer shall install a steel service mast.
6. The meter sockets shall meet the following specifications:
 - a. The latest revision of U.L. 414 and ANSI C12.7 Standards.
 - b. Must be U.L. listed.
 - c. Must have grounding connector for quadruplex.
 - d. Lug size – 2/0 minimum.
 - e. On 208/120v 4 Wire WYE services, the customer must provide the meter socket with 5th lug installed in the 9 o'clock position.
 - f. All meter sockets shall be equipped with L&G HQ-7 or equivalent heavy duty jaw clamping & bypass socket mechanism.
 - g. See Appendix A for list of approved meter sockets.**

B. Mounting:

1. Meter socket assembly, ground wire, and conduit shall be surface mounted and be securely fastened to the structure. The meter socket assembly shall be installed in a level and plumb position. **Flush mounted or recessed metering equipment and service lateral conduit embedded in a wall will not be permitted.**
2. Where the exterior wall is other than brick or concrete blocks, a support frame shall be installed behind the exterior wall to provide a solid mounting surface for the meter socket assembly.
3. Meter sockets, metering cabinets, and conduit straps shall be installed with the following:
 - a. Lead anchors or double helix concrete screws shall be used with brick or solid concrete surfaces.
 - b. Toggle bolts shall be used with other masonry siding.
 - c. Wood screws shall be used with solid wood surfaces.
 - d. All mounting hardware shall be minimum #12(1/4") corrosion resistant screws.
 - e. A minimum of 4 fasteners shall be used to install any socket or cabinet unless specifically stated otherwise.

4. An intersystem bonding termination bar shall be installed to facilitate the connection of other utility's ground to a common ground. The location of this device shall be located directly below the meter socket or meter combination socket.

a. See Appendix A for list of approved intersystem bonding termination bars.

5. If PVC is used for the conduit attached to the meter socket, the rigid metal elbow shall be grounded/bonded to the service ground rod unless it is isolated from possible contact by a minimum cover of 18 inches to any part of the elbow as per NEC Article 250.80, Service Raceways and Enclosures.

a. See Appendix A for list of approved grounding clamps.

C. Connections:

1. The Customer is responsible for termination of the incoming wiring if the wire terminates in a main breaker or fuse holder. The Company will terminate the incoming wire if it terminates on bus bar terminals. The main breaker will be removed when the service wire is being pulled by the Company.
2. Do not score load wire when removing insulation.
3. The Customer shall use wire brush or sandpaper to clean all conductors, apply a non-grit type inhibitor and tighten to manufacturer's specifications.

D. Meter Socket Marking:

1. **Before the meters are installed, each socket position and corresponding building unit, i.e. apt number or letter, Suite number or letter, tenant number or letter, or physical address served shall be accurately, clearly, and permanently labeled with an engraved plaque. These shall be screwed, bolted or riveted externally to the equipment. See figures for proper location. If the equipment is marked incorrectly, the customer shall be responsible for all costs incurred by LU for correcting the meter socket identification. Please note that marker ink or adhesive labels are examples of non-permanent labeling.**
2. **Letters or numbers on the engraved plaque shall be a minimum of one (1) inch in height of contrasting color, i.e., black and white, red and green, orange and blue, etc.**

E. Conductor marking

All neutral conductors shall be clearly marked with white tape at the meter socket assembly.

Note:
This service not available for 480Y/277V.

Caution!
Contact all utilities before digging

- ✓ Unit Disconnection means with lock-off provisions must accept Company padlock with 3/8" shackle
- * Provision for Company seal and Company padlock with 3/8" shackle
- ☒☒☒ Marking as required in Section 7.7.D

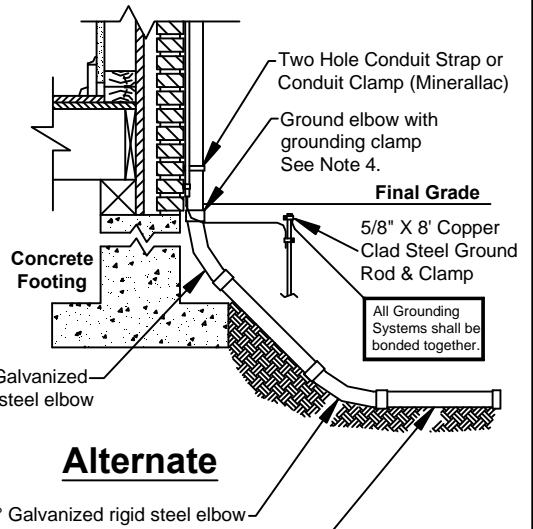
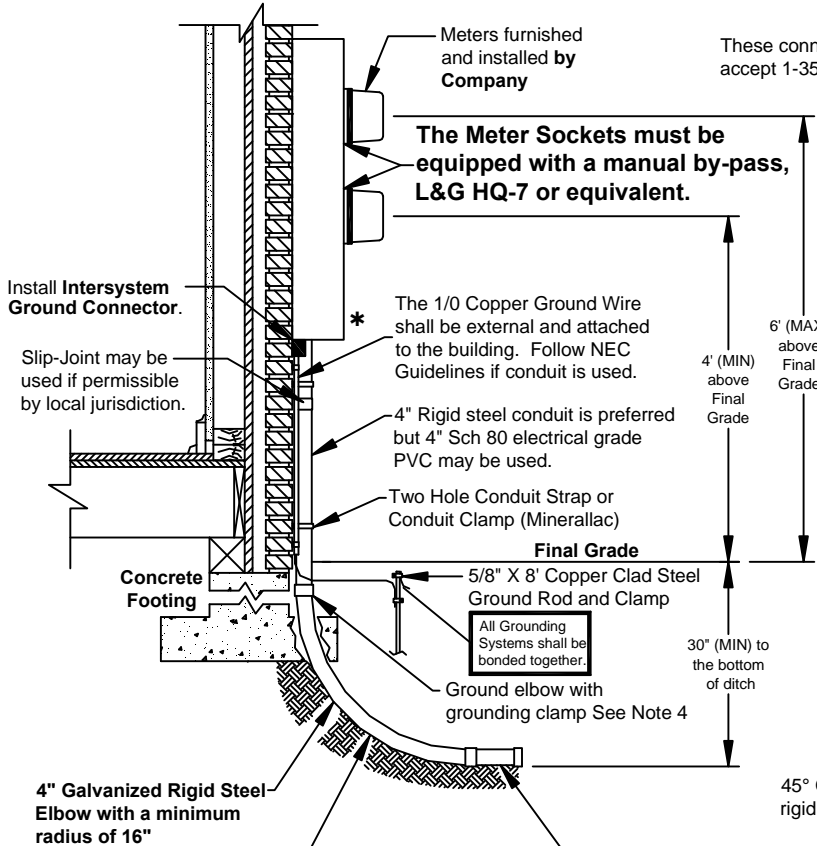
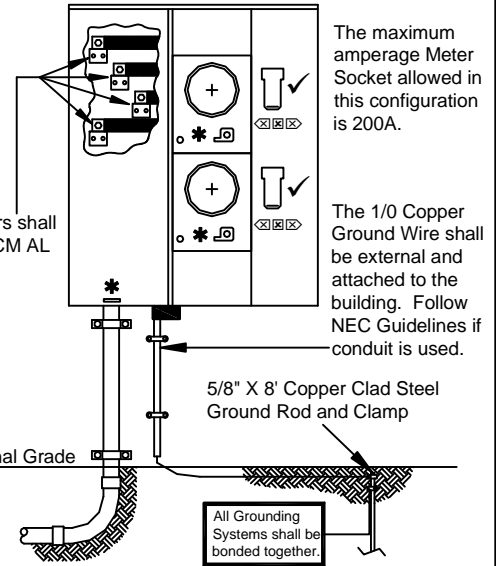

Preferred

Alternate

!!!! WARNING !!!!

If this elbow is not supported or if the soil under it is not well compacted, the conduit may pull out of the Meter Pack resulting in a possible failure of the service.

The conduit shall rest on the bottom of the trench and will point toward the service source. See Figure 38 & 39.

This denotes undisturbed earth.

NOTES:

1. A Conduit Vent may be needed depending on the service arrangement and terrain.
2. Line of Sight installation is required. See Definitions.
3. If the service route is longer than 100', contact the Company for conduit requirements.
4. A metal elbow that is installed in an underground installation of rigid nonmetallic conduit and isolated from possible contact by a minimum cover of 18 inches to any part of the elbow shall not be required to be grounded as per NEC Article 250.80, Service Raceways and Enclosures.
5. A 1/4" synthetic pull rope must be installed in the conduit.

All Equipment Furnished & Installed By Customer Unless Otherwise Noted.

08/14/19 KMH 07/15/09 SDS 07/15/05 SDS REVISIONS			Wiring of two Meters, Underground Service	
			DRAWN: LU	DWG. NO. G18A2144
	SCALE: NTS		FIGURE 56	
	DATE: 01/01/96			

Figure 56: Wiring of Two Meters, Underground Service

Note:
This service not available for 480Y/277V.

The Meter Sockets must be equipped with a manual by-pass, L&G HQ-7 or equivalent.

- * Provision for company seal and company padlock with 3/8" shackle
- ☒☒☒ Marking as required in Section 7.7.D
- ✓ Unit disconnection means with lock-off provisions must accept company padlock with 3/8" shackle

The maximum amperage Meter Socket allowed in this configuration is 200A.

Slip-Joint may be used if permissible by local jurisdiction.

Rigid steel conduit is preferred but Sch 80 electrical grade PVC may be used. Number and size of conduits may vary depending on service requirements. Contact the Company for details.

Copper ground wire as per NEC. This wire shall be external and attached to the building. Follow NEC Guidelines if Conduit is used.

Either install a #6 copper wire (Minimum) from the same connection point as the main Copper Ground Wire connection in the multi-meter incoming compartment or the ground rod to **Intersystem Ground Connector.**

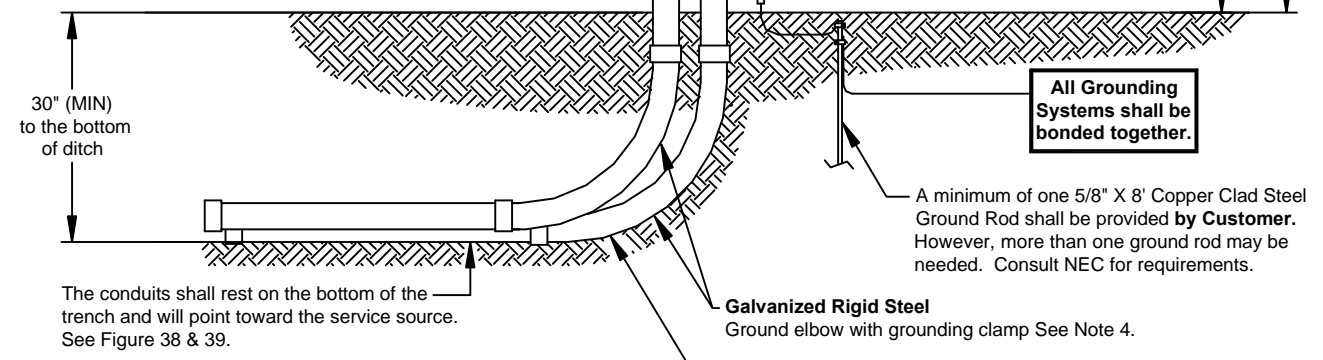

The number, type, and size of conduits will vary with each installation. Contact the Company for more information.

!!!! WARNING !!!!
 If this elbow is not supported or if the soil under it is not well compacted, the conduit may pull out of the Meter Pack resulting in a possible failure of the service.

If more than 6 meters are required, please contact the Company for configuration. As a minimum, Liberty Utilities will require the riser diagram and cut sheets as proposed by the Electrical Engineer.

← This denotes undisturbed earth.

Caution!
Contact all utilities before digging

NOTES:

1. A Conduit Vent may be needed depending on the service arrangement and terrain.
2. Line of Sight installation is required. See Definitions.
3. If the service route is longer than 100', contact the Company for conduit requirements.
4. A metal elbow that is installed in an underground installation of rigid nonmetallic conduit and isolated from possible contact by a minimum cover of 18 inches to any part of the elbow shall not be required to be grounded as per NEC Article 250.80, Service Raceways and Enclosures.
5. A 1/4" synthetic pull rope must be installed in the conduit.

All Equipment Furnished & Installed By Customer Unless Otherwise Noted.

08/14/19	KMH
03/18/10	SDS
07/15/09	SDS
05/17/05	SDS
REVISIONS	



Three to six Meters, Underground Service	
DRAWN: LU	DWG. NO. G18A2145
SCALE: NTS	FIGURE 57
DATE: 01/01/96	

Figure 57: Three to Six Meters, Underground Service

8.0 UNDERGROUND SERVICE FROM 3 PHASE PADMOUNT TRANSFORMER

8.1 CT METERING ON THE TRANSFORMER (Preferred Method)

A. General Notes:

1. **This method of service must be approved by the Company. This type of installation is limited to one Customer per transformer.**
2. The disconnection method may be composed of multiple disconnects to make up the full capacity of the service as long as there are not more than 6. If one disconnect is used and it is greater than 400 amps, it may be located on the interior of the building unless the authority having jurisdiction dictates otherwise. Disconnects of 400 amps and below will be located on the exterior of the building. **Please note that in all cases, the disconnects making up this service will be at the same location.**
3. **240/120 volt delta service is not available from a Pad Mounted Transformer.**
4. This arrangement may be utilized for services from 200 amps through 3000 amps.
5. **The Customer shall furnish and install the following: transformer pad, secondary trench and backfill, 8' x 5/8" copper clad ground rod, secondary conduits, and secondary conductors.**
6. The Customer shall install one - 4 inch galvanized rigid steel sweep ell (36" radius) in the primary side of the transformer pad throat (see Figures 58 & 60). Consult with the Company for the direction the conduit is to be pointed from the transformer pad.
7. The current transformers (CT), metering control cable, and meter will be furnished by the Company.
8. The Customer's Ground Wire (Grounding Conductor) is not required and will not be connected to the Company's transformer grounding system.

B. Installation:

1. The Customer shall provide and install the secondary conductors and conduit system. The secondary conductors shall extend above the transformer pad as per the table below:

Transformer Size (KVA)	Minimum Conductor Length (INCHES)
75-500	48
750-2500	72

2. The point of delivery for this type of service is the secondary terminals of the transformer.
3. **The Customer is responsible for all future maintenance on the secondary service lateral conductors and conduit from the secondary terminals of the three phase transformer to the Customer's service equipment.**
4. The meter socket shall be provided and installed on the transformer by the Company.

5. The current transformers (CT) will be installed in the transformer secondary compartment by the Company.

C. Connections:

1. **The Company shall connect all secondary conductors to the secondary terminals of the three phase transformer. The Company shall provide the connectors.**
2. The Company will install and terminate the metering cable in the transformer and meter socket.

D. Conductor marking

All customer provided phase and neutral conductors shall be clearly marked with tape at the point of delivery.

E. Phase Rotation

On three-phase installations to insure proper equipment operation, the Customer is responsible for verifying phase rotation at the time of service connection.

NOTES:

1. This method of service must be approved by the Company.
2. **The Customer shall provide the Transformer Pad per the Company's specifications. The Company is to inspect the pad forms, reinforcement, and conduits before the transformer pad is poured.**
3. All equipment to be furnished and installed by the Customer prior to any work by the Company unless otherwise noted.
4. Protective Bushings are required on all conduits. Conduits shall be a minimum of 6" below the top of the concrete pad.
5. The Company shall make all Secondary Conductor Connections in the transformer and all Metering Control Cable Connections in the meter socket and transformer secondary compartment.

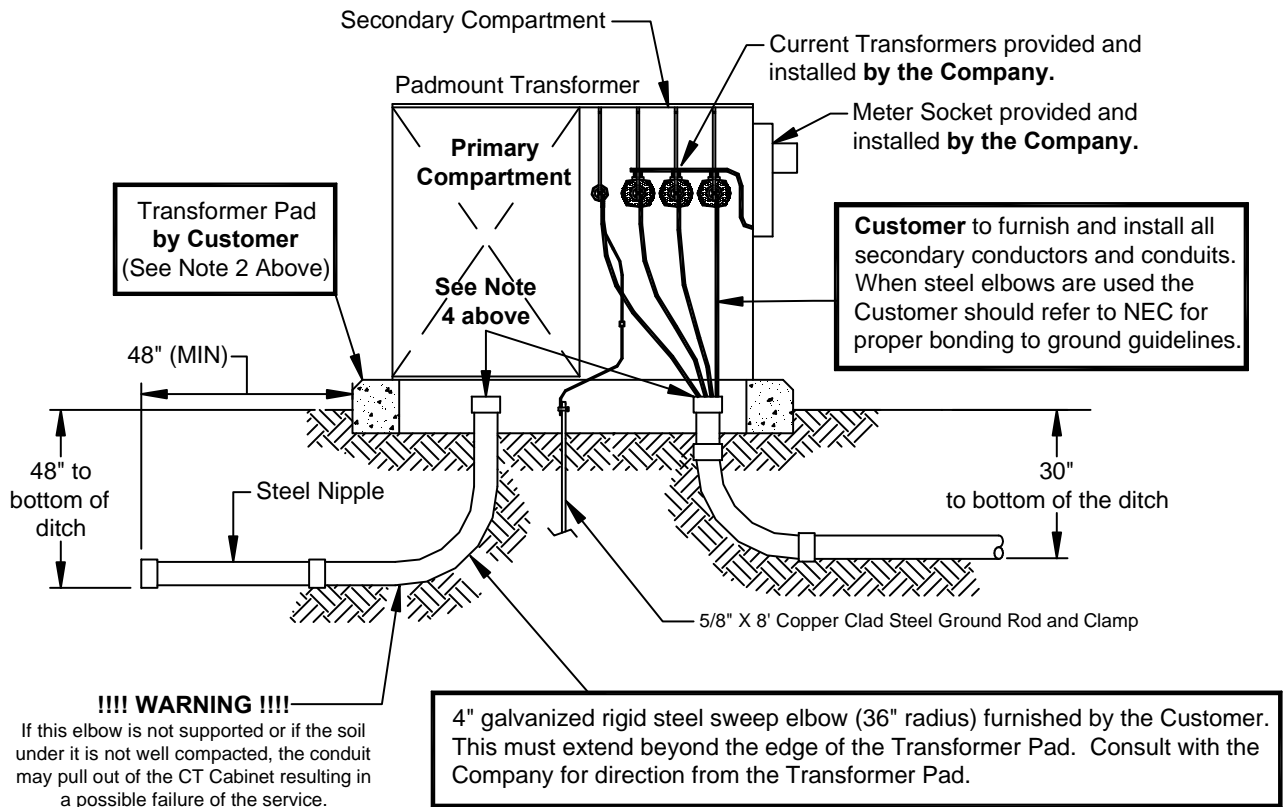

Amount of Conductor Provided in Transformer Secondary Compartment as Measured From the Top of the Transformer Pad	
Transformer Size (kVA)	Minimum Conductor Length
75 - 500	48"
750 - 2500	72"

This denotes undisturbed earth.

All Equipment Furnished & Installed By Customer Unless Otherwise Noted.

08/06/19 KMH 05/17/05 SDS REVISIONS		Three Phase, Padmount Transformer Serving One Customer with Meter on Transformer	
		DRAWN: LU	DWG. NO. G18A2146
		SCALE: NTS	FIGURE 58
		DATE:01/01/96	

Figure 58: 3 Phase Padmount Transformer Serving 1 Customer with Meter on Transformer

8.2 METERING ON THE BUILDING

A. General Notes:

1. **This method of service must be approved by the Company.**
2. The disconnection method may be composed of multiple disconnects to make up the full 1200 amp capacity of the service as long as there are not more than 6. If one disconnect is used that it is greater than 400 amps, it may be located on the interior of the building unless the authority having jurisdiction dictates otherwise. Disconnects of 400 amps and below will be located on the exterior of the building. **Please note that in all cases, the disconnects making up this service will be at the same location.**
3. **240/120 volt delta service is not available from a Pad Mounted Transformer.**
4. This arrangement may be utilized for services from 200 amps through 3000 amps.
5. **The Customer is responsible for the following: transformer pad, secondary trench and backfill, and secondary conduits.**
6. The Company shall provide and install the secondary conductor and connectors.
7. The Customer shall install one - 4 inch galvanized rigid steel sweep ell (36" radius) in the primary side of the transformer pad throat (see Figures 59 & 60). Consult with the Company for the direction the conduit is to be pointed from the transformer pad.
8. The metering for this type of service is as described in Section 7.4, 7.5, 7.6, or 7.7.

B. Installation:

1. The point of delivery for this type of service is at the connections inside the metering equipment.
2. **The Company is responsible for all future maintenance of the secondary service lateral conductors and conduit from the secondary terminals of the three-phase transformer to the metering equipment.**

C. Connections:

The Company shall connect all service lateral conductors to the secondary terminals of the three phase transformer, and in the metering equipment.

NOTES:

1. This method of service must be approved by the Company.
2. **The Customer shall provide the Transformer Pad per the Company's specifications. The Company is to inspect the pad forms, reinforcement, and conduits before the transformer pad is poured.**
3. All equipment to be furnished and installed **by the Customer** prior to any work by the Company unless otherwise noted.
4. Protective Bushings are required on all conduits. Conduits shall be a minimum of 6" below the top of the concrete pad.
5. The Company shall make all Secondary Conductor Connections in the transformer and all Metering Control Cable Connections in the meter socket and transformer secondary compartment.

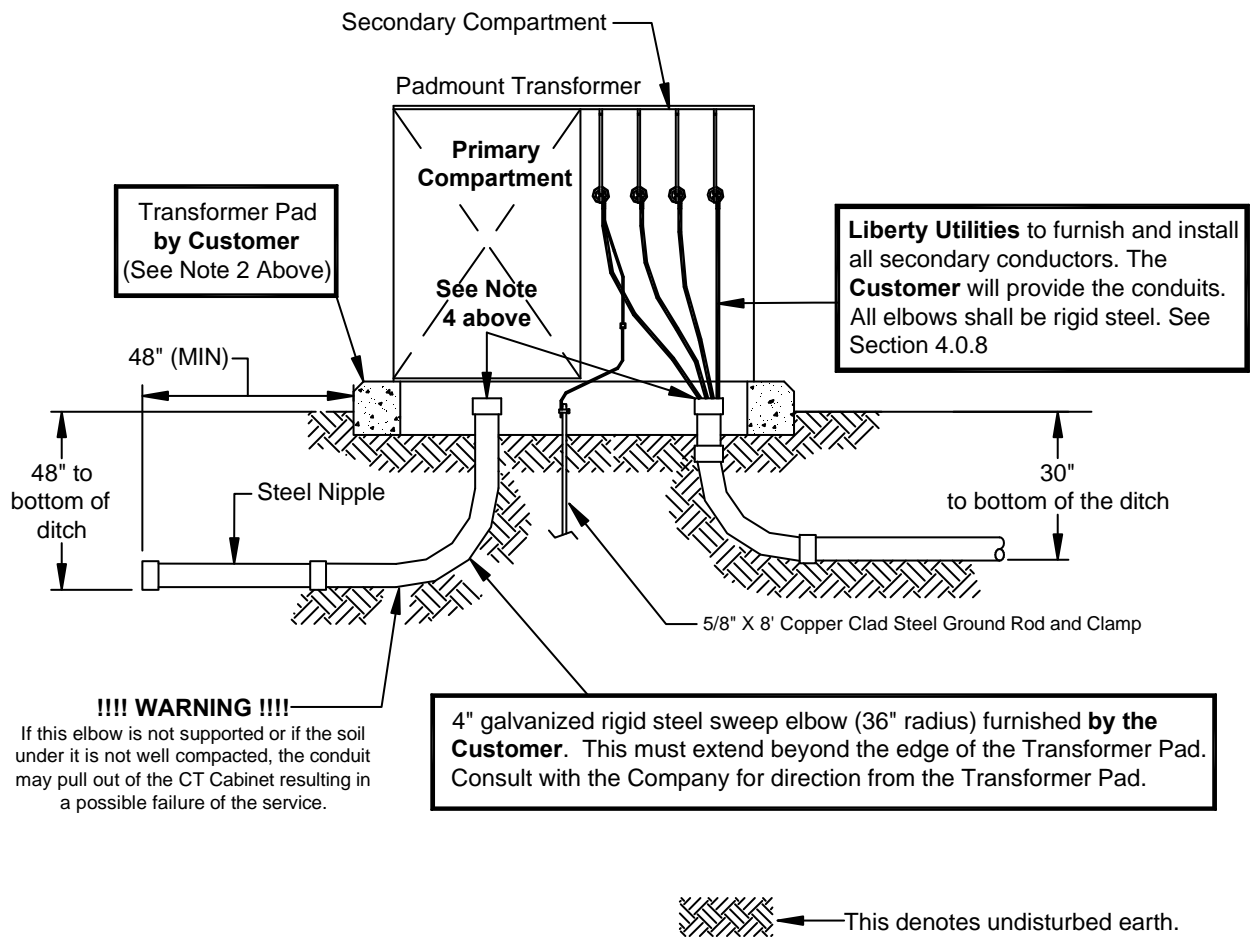

All Equipment Furnished & Installed By Customer Unless Otherwise Noted.

08/06/19 KMH REVISIONS		Three Phase, Padmount Transformer Installation	
		DRAWN: LU	DWG. NO. G18A2147
		SCALE: NTS	FIGURE 59
		DATE: 12/03/06	

Figure 59: Three Phase Padmount Transformer Installation

NOTES:

1. Pad must be level.
2. The Company is to inspect the transformer pad forms, reinforcement, and conduits before the Transformer Pad is poured.

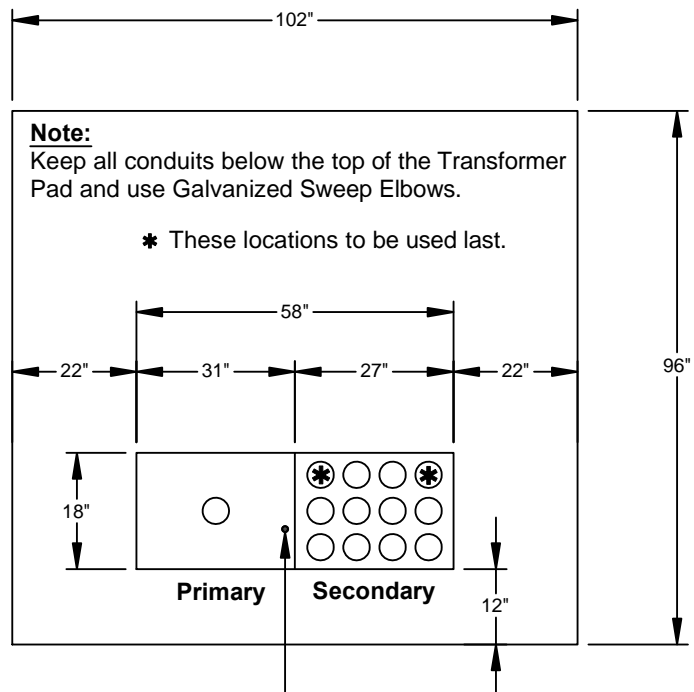

A 5/8" X 8' Copper Clad Steel Ground Rod shall be provided and installed by Customer.

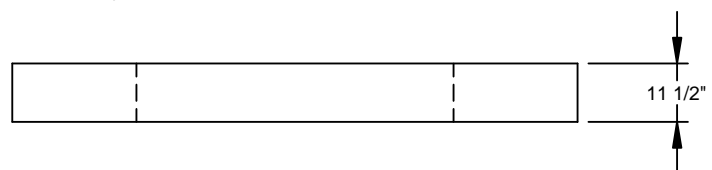

01/29/20 SMS 08/14/19 KMH REVISIONS		Large Transformer Pad, Physical Specifications	
		DRAWN: LU	DWG. NO. G18A2148
		SCALE: NTS	FIGURE 60
		DATE:01/01/96	

Figure 60: Large Transformer Pad, Physical Specifications

NOTES:

1. Small pad allowed with LU approval only.
2. Pad must be level.
3. The Company is to inspect the transformer pad forms, reinforcement, and conduits before the Transformer Pad is poured.

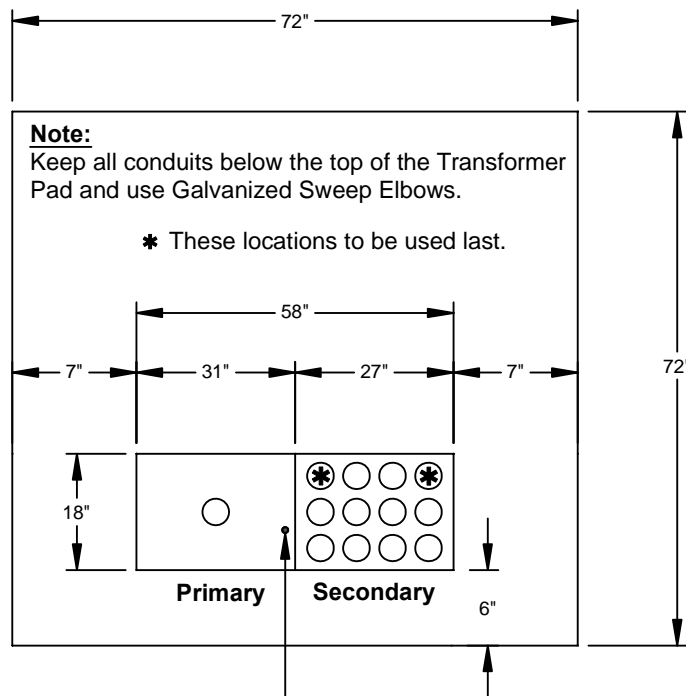

A 5/8" X 8' Copper Clad Steel Ground Rod shall be provided and installed by Customer.

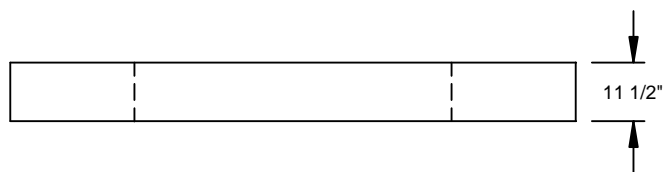

01/29/20 SMS REVISIONS			Small Transformer Pad, Physical Specifications	
			DRAWN: LU	DWG. NO. G18A2149
	SCALE: NTS		FIGURE 61	
	DATE: 08/14/19			

Figure 61: Small Transformer Pad, Physical Specifications

The Company shall inspect the pad forms, reinforcement, and conduit placement before the pad is poured. If this is not done, the customer will be required to remove the poured pad and reinstall it.

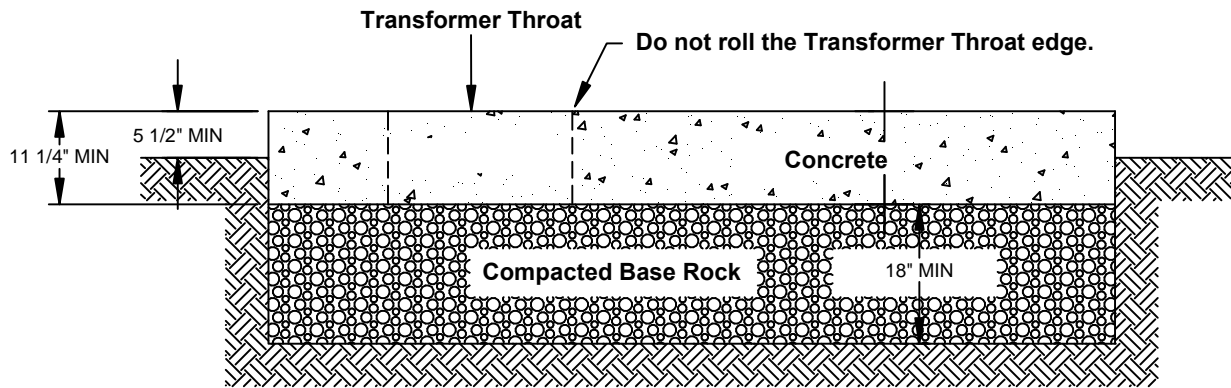

NOTES:
 CROSSHATCHED AREA DENOTES UNDISTURBED OR COMPACTED SOIL, FAILURE TO PROVIDE COMPACTED SOIL MAY RESULT IN DAMAGE TO CABLES, CONDUIT, AND TRANSFORMER ENCLOSURE.

NOTES:

1. ALL CONCRETE SHALL HAVE A 28 DAY COMPRESSIVE STRENGTH OF 3000 PSI. ALL EXPOSED EXTERIOR CONCRETE SHALL BE AIR ENTRAINED (6%±1%). SLUMP OF 3" SHALL BE USED.
2. CLEAR CONCRETE COVER FOR STEEL SHALL BE AS FOLLOWS:
 CONCRETE CAST AGAINST AND PERMANENTLY EXPOSED TO EARTH.....3"

 CONCRETE EXPOSED TO EARTH OR WEATHER (FORMED & Poured).....2"
3. THE USE OF ADMIXTURES, INCLUDING CALCIUM CHLORIDE, IS NOT PERMITTED.
4. PAD SHALL BE Poured MONOLITHICALLY, WITH NO COLD JOINTS.
5. HONEY COMBING OR POT MARKS IN THE FACE OF THE SLAB ARE NOT ACCEPTABLE. IF THIS OCCURS, THE CUSTOMER MAY BE REQUIRED TO REPLACE THE TRANSFORMER PAD.
6. NO FOOTING IS TO BE EXCAVATED WITHOUT HAVING REINFORCING AND CONCRETE READY TO PLACE WITHIN THAT WORKING DAY.
7. IN THE EVENT THAT ORGANIC SOIL IS FOUND BELOW FOOTING, THE SOIL SHALL BE REMOVED AND REPLACED WITH COMPACTED BASE ROCK.
8. ALL REINFORCING BARS SHALL BE DEFORMED #5 BILLET STEEL CONFORMING TO ASTM A615, GRADE 60. BARS SHALL BE FREE OF ANY GREASE, RUST, OR SCALE AT THE TIME OF PLACEMENT.
9. TOP SURFACES OF CONCRETE SHALL HAVE A STEEL TROWEL FINISH.
10. ENTIRE PAD MUST BE LEVEL. NO GROUT ALLOWED.
11. THE TRANSFORMER PAD SHALL BE Poured FOR A MINIMUM OF 4 DAYS BEFORE ANY TRANSFORMER CAN BE SET AND ALL FORMS MUST BE REMOVED.

08/06/19 KMH REVISIONS		Transformer Pad, Specifications, Concrete & Foundation Detail	
		DRAWN: LU	DWG. NO. G18A2151
		SCALE: NTS	FIGURE 63
		DATE:01/01/96	

Figure 63: Transformer Pad Specifications, Concrete & Foundation Detail

NOTES:

1. No portion of the building will extend over the Transformer Clear Zone.
2. The Transformer must be accessible at all times. There shall not be any obstruction to access the transformer at any time or in any way.
3. All fencing, barriers, etc. around the transformer must provide adequate ventilation shall be approved by the Company prior to installation.
4. Clear zone to the transformer shall not have a grade difference or more than 1' from the building to front edge of the clear zone and side to side.

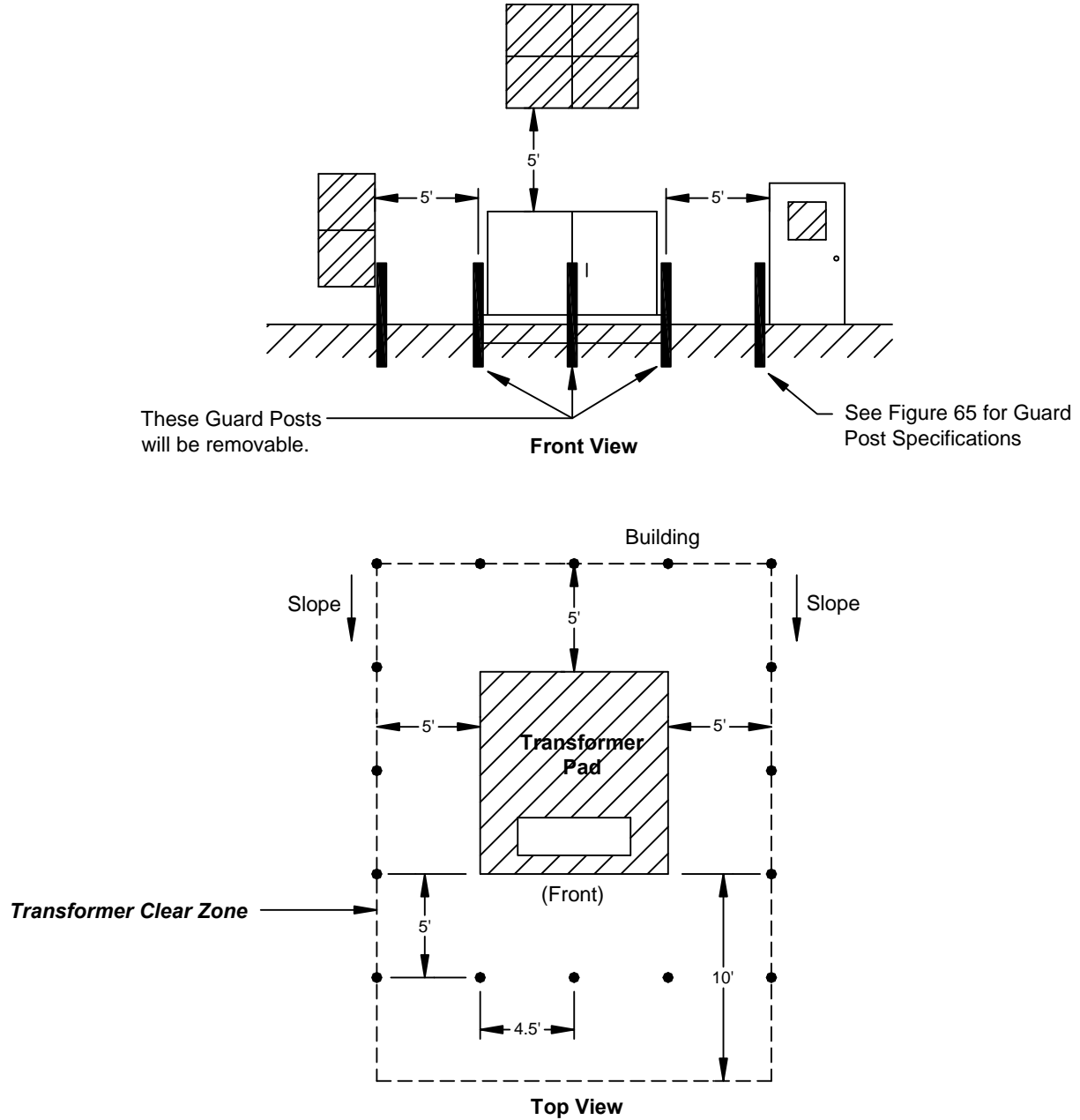

The **Transformer Clear Zone** is illustrated above by dashed lines. The Transformer Clear Zone shall not be obstructed in anyway. Unless the Transformer is otherwise protected from vehicular traffic, Guard Posts shall be installed with 5' spacing on the exposed sides as shown.

REVISIONS			Transformer Clear Zone Specifications	
	DRAWN: LU	DWG. NO. G18A2152		
	SCALE: NTS	DATE:08/06/19	FIGURE 64	

Figure 64: Transformer Clear Zone Specifications

Caution!
Contact all utilities
before digging



Removable Post

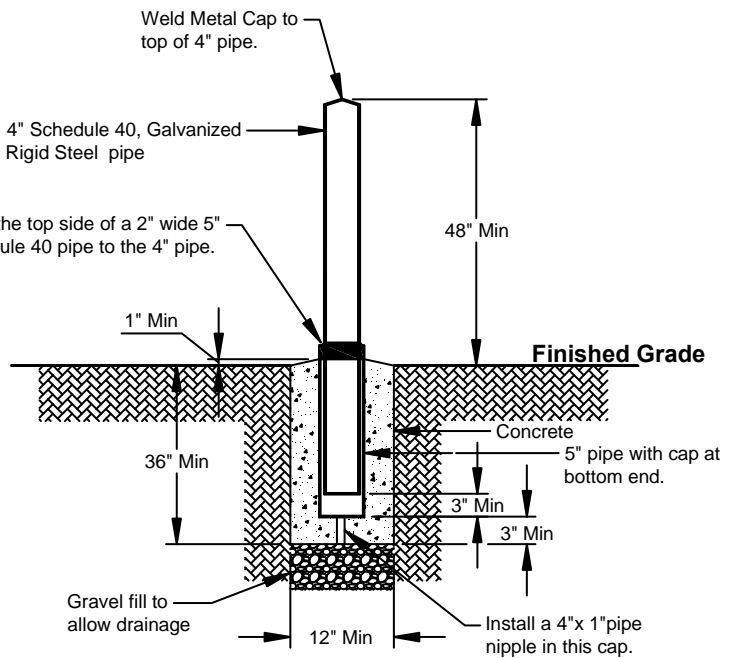
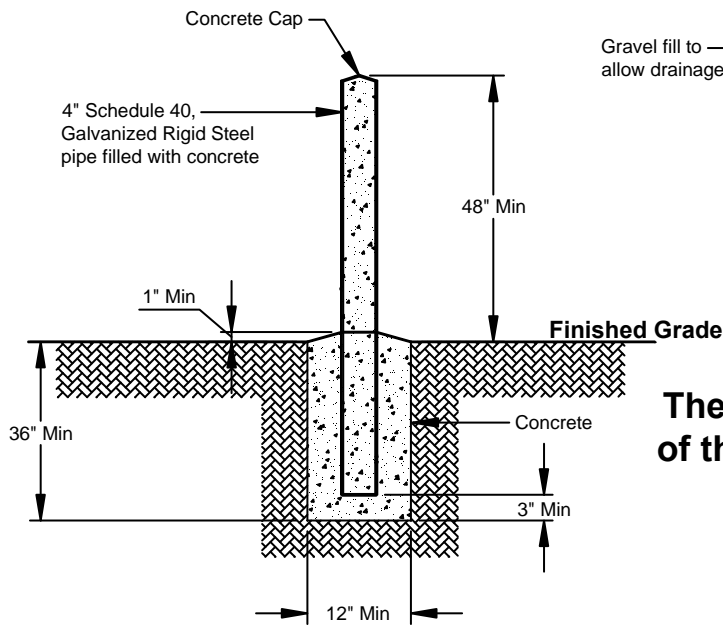

Fixed Post

The post may be painted with color of the customer's choice or covered with a plastic post sleeve.

 This denotes undisturbed earth.

All Equipment Furnished & Installed By Customer Unless Otherwise Noted.

08/06/19 KMH REVISIONS			Guard Post Installation	
			DRAWN: LU	DWG. NO. G18A2153
	SCALE: NTS		FIGURE 65	
	DATE: 11/08/06			

Figure 65: Guard Post Installation



NOTES:

1. The sign material shall be an etched laminated plastic. The surface shall be black and the substrate shall be white. This is so specified to have the letters appear as white when they are etched into the plastic.
2. The lettering for the "CAUTION" shall be 3/4" tall.
3. All other lettering shall be 1/2" tall.
4. This plaque shall be screwed or bolted externally to the structure at the meter location. If this service is provided by a Padmount Transformer and the meter is at this point, the plaque will be provided to LU for application to the secondary sided of the transformer door set.
5. The location is illustrated by the example in the plaque diagram above.

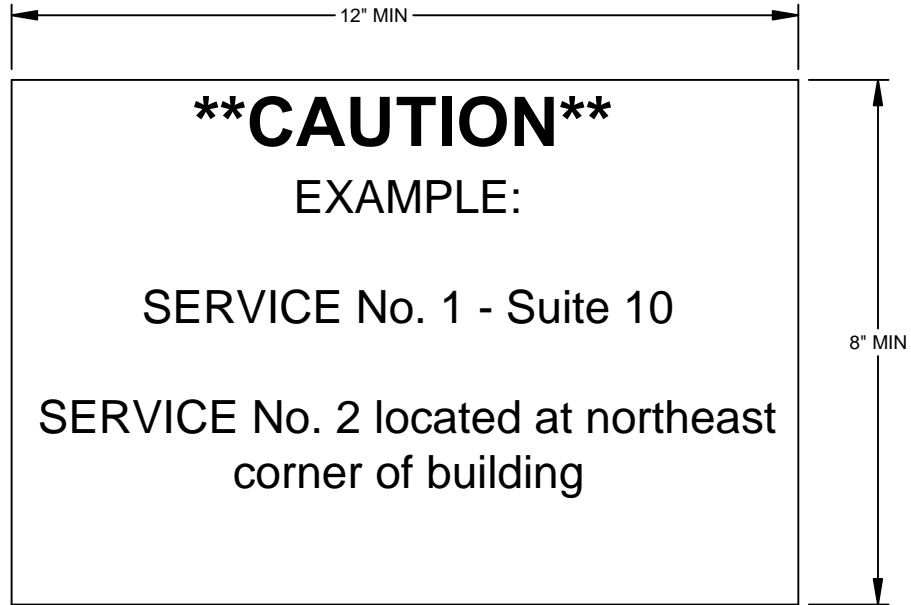
REVISIONS		Multiple Service Point Identification Plaque	
		DRAWN: KMH	DWG. NO. G18A2154
		SCALE: NTS	FIGURE 66
		DATE:08/14/19	

Figure 66: Multiple Service Point Identification Plaque

Appendix A

Commercial – Approved Equipment Examples

Note: Please get prior approval from Company before purchasing equipment not listed in this Appendix.

Individual Meter Sockets – Overhead

SERVICE SIZE	MILBANK CATALOG #	EATON CATALOG #	TALON/SIEMENS CATALOG #	DURHAM CATALOG #
100A	U7487-RL-TG U7490-RL-TG	UTH101B UTH111B URTH101B URTH111B	UAT111-0G UAT121-0G	UT-RS101B UT-RS111B URT-RS101B URT-RS111B
200A	U7017-RL-TG U7021-RL-TG U7040-RL-TG	UTH202B UTH212B UTH203B UTH213B URTH202B URTH212B URTH203B URTH213B	UAT317-0G UAT327-0G UAT417-0G UAT427-0G	UT-RS202B UT-RS213B URT-RS202B URT-RS213B
320A	U4702-X & (2)K1350	UTH4330UCH ARP00429CH ARP00427CH	47704-01+(2)H56732	UT-H4309T

Individual Meter Sockets – Overhead (5th Lug)

SERVICE SIZE	MILBANK CATALOG #	EATON CATALOG #	TALON/SIEMENS CATALOG #	DURHAM CATALOG #
100A	U7487-RL-TG-5T9 U7490-RL-TG-5T9	UGTH101B UGTH111B UGRTH101B UGRTH111B	UAT111-0BG UAT121-0BG	UGT-RS101B UGT-RS111B UGRT-RS101B UGRT-RS111B
200A	U7017-RL-TG-5T9 U7021-RL-TG-5T9 U7040-RL-TG-5T9	UGTH202B UGTH212B UGTH203B UGTH213B UGRTH202B UGRTH212B UGRTH203B UGRTH213B	UAT317-0BG UAT327-0BG UAT417-0BG UAT427-0BG	UGT-RS202B UGT-RS213B UGRT-RS202B UGRT-RS213B
320A	U4505-X & (2)K1350	UTH4330UCH ARP00429Ch ARP00862CH	47705-02+(2)H56732	UGT-H4309T

Combination Meter Sockets – Overhead

SERVICE SIZE	MILBANK CATALOG #	EATON CATALOG #	TALON/SIEMENS CATALOG #	DURHAM CATALOG #
100A	U5168-XTL-100 U5169-XTL-100	MB816B200BTS*	MC0816B1200CT*	1009663-EDE*
200A	U5168-XTL-200 U5169-XTL-200	MB816B200BTS	MC0816B1200CT	1009663-EDE
320A	U5059-X-2/200 & K1350	N/A	LG0816B1400RLT+H56732-2 MC0816B1400RLTM+H56732-2 MM04404L1400RLM+(2)QN220RH	UHC344N5T

* To provide 100A service, this socket will be installed and a separate Customer supplied 100A breaker will be installed to supply the 100A service.

Combination Meter Sockets – Overhead (5th Lug)

SERVICE SIZE	MILBANK CATALOG #	EATON CATALOG #	TALON/SIEMENS CATALOG #	DURHAM CATALOG #
100A	U5168-XTL-100 & 5T8K2 U5169-XTL-100 & 5T8K2	MB816B200STD*	MC0816B1200CT+EC5J2*	1009663A-EDE*
200A	U5168-XTL-200 & K5T U5169-XTL-200 & K5T	MB816B200STD	MC0816B1200CT+EC5J2	1009663A-EDE
320A	U5059-X-2/200 & K1350 & K3865	N/A	LG0816B1400RLT+H35815-2+H56732-2 MC0816B1400RLTM+H35815-2+H56732-2 MM0404L1400RLM+H35815-2+(2)QN220RH	UHC344N5T-5J

* To provide 100A service, this socket will be installed and a separate Customer supplied 100A breaker will be installed to supply the 100A service.

Duplex Meter Sockets – Overhead

SERVICE SIZE	MILBANK CATALOG #	EATON CATALOG #	TALON/SIEMENS CATALOG #	DURHAM CATALOG #
2-100A	U2852-X-HSP & (2)K1539*	1MP2122R+DS_H2*	WTG2211*	SBG1012B*
2-200A	U2862-X-HSP & (2)K1539**	1MP2204R+DS_MH+(6)1MPLK1**	WTG4212**	SBG2022T

* To provide 100A service, these sockets will be installed with Customer supplied 100A breakers.

** To provide 200A service, these sockets will be installed with Customer supplied 200A breakers.

Duplex Meter Sockets – Overhead (5th Lug)

SERVICE SIZE	MILBANK CATALOG #	EATON CATALOG #	TALON/SIEMENS CATALOG #	DURHAM CATALOG #
2-100A	U2852-X-HSP & (2)K1539 & (2)K2381*	1MP2122R+DS_H2+(2)1MM5JK*	WTG2211RJ*	SBG1012B5J*
2-200A	U2862-X-HSP & (2)K1539 & (2)K2381**	1MP2204R+DS_MH+(2)1MM5JK+(6)1MPLK1**	WTG4212RJ**	SBG2022T5J

* To provide 100A service, these sockets will be installed with Customer supplied 100A breakers.

** To provide 200A service, these sockets will be installed with Customer supplied 200A breakers.

Meter Stacks (3 To 6) – Overhead

SERVICE SIZE	MILBANK CATALOG #	EATON CATALOG #	TALON/SIEMENS CATALOG #	DURHAM CATALOG #
3-100A	U2853-X-HSP & (3)K1539*	1MP3124R+DS_MH+(9)1MPLK1*	WTG3311*	SBG1013T*
4-100A	U2854-X-HSP & (4)K1539*	1MP4124R+DS_MH+(12)1MPLK1*	WTG4411* WTG5411*	SBG1014T*
5-100A	U2855-X-HSP & (5)K1539*	1MP5126R+DS_MH+(15)1MPLK1*	WTG4511* WTG6511*	SBG1015T*
6-100A	U2856-X-HSP & (6)K1539*	1MP6126R+DS_MH+(18)1MPLK1*	WTG6611*	SBG1016T*
3-200A	U2863-X-HSP & (3)K1539**	1MP3206R+DS_MH+(9)1MPLK1**	WTG4312**	SBG2023T
4-200A	U2864-X-HSP & (4)K1539**	1MP4206R+DS_MH+(12)1MPLK1**	WTG6412**	SBG2024T
5-200A	U2865-X-HSP & (5)K1539**	1MP5206R+DS_MH+(15)1MPLK1**	WTG6512**	SBG2025T
6-200A	U2866-X-HSP & (6)K1539**	1MP6206R+DS_MH+(18)1MPLK1**	WTG8612**	SBG2026T

* To provide 100A service, these sockets will be installed with Customer supplied 100A breakers.

** To provide 200A service, these sockets will be installed with Customer supplied 200A breakers.

Meter Stacks (3 To 6) – Overhead (5th Lug)

SERVICE SIZE	MILBANK CATALOG #	EATON CATALOG #	TALON/SIEMENS CATALOG #	DURHAM CATALOG #
3-100A	U2853-X-HSP & (3)K1539 & (3)K2381*	1MP3124R+DS_MH+(3)1MM5JK+(9)1MPLK1*	WTG3311RJ*	SBG1013T5J*
4-100A	U2854-X-HSP & (4)K1539 & (4)K2381*	1MP4124R+DS_MH+(4)1MM5JK+(12)1MPLK1*	WTG4411RJ*	SBG1014T5J*
5-100A	U2855-X-HSP & (5)K1539 & (5)K2381*	1MP5126R+DS_MH+(5)1MM5JK+(15)1MPLK1*	WTG4511RJ* WTG6511RJ*	SBG1015T5J*
6-100A	U2856-X-HSP & (6)K1539 & (6)K2381*	1MP6126R+DS_MH+(6)1MM5JK+(18)1MPLK1*	WTG4611RJ* WTG6611RJ*	SBG1016T5J*
3-200A	U2863-X-HSP & (3)K1539 & (3)K2381**	1MP3206R+DS_MH+(3)1MM5JK+(9)1MPLK1**	WTG4312RJ**	SBG2023T5J
4-200A	U2864-X-HSP & (4)K1539 & (4)K2381**	1MP4206R+DS_MH+(4)1MM5JK+(12)1MPLK1**	WTG4412RJ** WTG6412RJ**	SBG2024T5J
5-200A	U2865-X-HSP & (5)K1539 & (5)K2381**	1MP5206R+DS_MH+(5)1MM5JK+(15)1MPLK1**	WTG6512RJ**	SBG2025T5J
6-200A	U2866-X-HSP & (6)K1539 & (6)K2381**	1MP6206R+DS_MH+(6)1MM5JK+(18)1MPLK1**	WTG8612RJ**	SBG2026T5J

* To provide 100A service, these sockets will be installed with Customer supplied 100A breakers.

** To provide 200A service, these sockets will be installed with Customer supplied 200A breakers.

Individual Meter Sockets – Underground

SERVICE SIZE	MILBANK CATALOG #	EATON CATALOG #	TALON/SIEMENS CATALOG #	DURHAM CATALOG #
200A	U7018-O-TG U7018-XL-TG UL7040-O-TG UL7040-XL-TG U7043-XL-TG	UTH212A	UAT417-XG UAT417-PG UAT427-XG UAT427-PG	UT-RS213A UT-RS213C URT-RS213A URT-RS213C
		UTH213A		
		UTH212C		
		UTH213C		
		URTH212A		
		URTH213A		
		URTH212C		
320A	U4702-X & (2)K1350	UTH4330UCH	47704-01+H56933+(2)H56732	UT-H4309U
		ARP00429CH		
		ARP00427CH		

Individual Meter Sockets – Underground (5th Lug)

SERVICE SIZE	MILBANK CATALOG #	EATON CATALOG #	TALON/SIEMENS CATALOG #	DURHAM CATALOG #
200A	U7018-O-TG-5T9 U7018-XL-TG-5T9 UL7040-O-TG-5T9 UL7040-XL-TG-5T9 U7043-XL-TG-5T9	UGTH212A	UAT417-XBG UAT417-PBG UAT427-XBG UAT427-PBG	UGT-RS213A UGT-RS213C UGRT-RS213A UGRT-RS213C
		UGTH213A		
		UGTH212C		
		UGTH213C		
		UGRTH212A		
		UGRTH213A		
320A	U4505-X & (2)K1350	UTH4330UCH	47705-82KCPL	UGT-H4309U
		ARP00429Ch		
		ARP00862CH		

Combination Meter Sockets – Underground

SERVICE SIZE	MILBANK CATALOG #	EATON CATALOG #	TALON/SIEMENS CATALOG #	DURHAM CATALOG #
200A	U5168-XTL-200	MB816200BTS	MC0816B1200CT	1009663-EDE
	U5169-XTL-200			
320A	U5059-X-2/200 & K1350	N/A	LG0816B1400RLT	UHC344N5U
			MC0816B1400RLTM MM0404L1400RLM+(2)QN2200RH	

Combination Meter Sockets – Underground (5th Lug)

SERVICE SIZE	MILBANK CATALOG #	EATON CATALOG #	TALON/SIEMENS CATALOG #	DURHAM CATALOG #
200A	U5168-XTL-200 & K5T	MB816B200STD	MC0816B1200CT+EC5J2	1009663A-EDE
	U5169-XTL-200 & K5T			
320A	U5059-X-2/200 & K1350 & K3865	N/A	LG0816B1400RLT+H35815-2	UHC344N5U-5J
			MC0816B1400RLTM+H35815-2 MM0404L1400RLM+H35815-2+(2)QN2200RH	

Duplex Meter Sockets – Underground

SERVICE SIZE	MILBANK CATALOG #	EATON CATALOG #	TALON/SIEMENS CATALOG #	DURHAM CATALOG #
2-100A	U2852-X-HSP & (2)K1539*	1MP2122R*	WTG2211*	SBG1012C*
2-200A	U2862-X-HSP & (2)K1539**	1MP2204R+(6)1MPLK1**	WTG4212**	SBG2022U

* To provide 100A service, these sockets will be installed with Customer supplied 100A breakers.

** To provide 200A service, these sockets will be installed with Customer supplied 200A breakers.

Duplex Meter Sockets – Underground (5th Lug)

SERVICE SIZE	MILBANK CATALOG #	EATON CATALOG #	TALON/SIEMENS CATALOG #	DURHAM CATALOG #
2-100A	U2852-X-HSP & (2)K1539 & (2)K2381*	1MP2122R+(2)1MM5JK*	WTG2211RJ*	SBG1012C5J*
2-200A	U2862-X-HSP & (2)K1539 & (2)K2381**	1MP2204R+(2)1MM5JK+(6)1MPLK1**	WTG4212RJ**	SBG2022U5J

* To provide 100A service, these sockets will be installed with Customer supplied 100A breakers.

** To provide 200A service, these sockets will be installed with Customer supplied 200A breakers.

Meter Stacks (3 To 6) – Underground

SERVICE SIZE	MILBANK CATALOG #	EATON CATALOG #	TALON/SIEMENS CATALOG #	DURHAM CATALOG #
3-100A	U2853-X-HSP & (3)K1539*	1MP3124R+(9)1MPLK1*	WTG3311*	SBG1013U*
4-100A	U2854-X-HSP & (4)K1539*	1MP4124R+(12)1MPLK1*	WTG4411* WTG5411*	SBG1014U*
5-100A	U2855-X-HSP & (5)K1539*	1MP5126R+(15)1MPLK1*	WTG4511* WTG6511*	SBG1015U*
6-100A	U2856-X-HSP & (6)K1539*	1MP6126R+(18)1MPLK1*	WTG6611*	SBG1016U*
3-200A	U2863-X-HSP & (3)K1539**	1MP3206R+(9)1MPLK1**	WTG4312**	SBG2023U
4-200A	U2864-X-HSP & (4)K1539**	1MP4206R+(12)1MPLK1**	WTG6412**	SBG2024U
5-200A	U2865-X-HSP & (5)K1539**	1MP5206R+(15)1MPLK1**	WTG6512**	SBG2025U
6-200A	U2866-X-HSP & (6)K1539**	1MP6206R+(18)1MPLK1**	WTG8612**	SBG2026U

* To provide 100A service, these sockets will be installed with Customer supplied 100A breakers.

** To provide 200A service, these sockets will be installed with Customer supplied 200A breakers.

Meter Stacks (3 To 6) – Underground (5th Lug)

SERVICE SIZE	MILBANK CATALOG #	EATON CATALOG #	TALON/SIEMENS CATALOG #	DURHAM CATALOG #
3-100A	U2853-X-HSP & (3)K1539 & (3)K2381*	1MP3124R+(3)1MM5JK+(9)1MPLK1*	WTG3311RJ*	SBG1013U5J*
4-100A	U2854-X-HSP & (4)K1539 & (4)K2381*	1MP4124R+(4)1MM5JK+(12)1MPLK1*	WTG4411RJ*	SBG1014U5J*
5-100A	U2855-X-HSP & (5)K1539 & (5)K2381*	1MP5126R+(5)1MM5JK+(15)1MPLK1*	WTG4511RJ* WTG6511RJ*	SBG1015U5J*
6-100A	U2856-X-HSP & (6)K1539 & (6)K2381*	1MP6126R+(6)1MM5JK+(18)1MPLK1*	WTG4611RJ* WTG6611RJ*	SBG1016U5J*
3-200A	U2863-X-HSP & (3)K1539 & (3)K2381**	1MP3206R+(3)1MM5JK+(9)1MPLK1**	WTG4312RJ**	SBG2023U5J
4-200A	U2864-X-HSP & (4)K1539 & (4)K2381**	1MP4206R+(4)1MM5JK+(12)1MPLK1**	WTG4412RJ** WTG6412RJ**	SBG2024U5J
5-200A	U2865-X-HSP & (5)K1539 & (5)K2381**	1MP5206R+(5)1MM5JK+(15)1MPLK1**	WTG6512RJ**	SBG2025U5J
6-200A	U2866-X-HSP & (6)K1539 & (6)K2381**	1MP6206R+(6)1MM5JK+(18)1MPLK1**	WTG8612RJ**	SBG2026U5J

* To provide 100A service, these sockets will be installed with Customer supplied 100A breakers.

** To provide 200A service, these sockets will be installed with Customer supplied 200A breakers.

CT/Connection Cabinet

SERVICE SIZE	MILBANK CATALOG #	TALON/SIEMENS CATALOG #	DURHAM CATALOG #
200A	N/A	N/A	242416-RDW
600A TO 800A	363616-CT3R-WB	LG163636CTS1	363616-DDW
1,000A TO 1,200A	484816-CT3R-WB	N/A	484818-DDW

Intersystem Bonding Termination Bar



MANUFACTURER	CATALOG #
ARLINGTON	GBB50

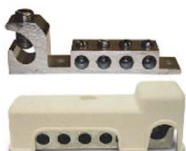

MANUFACTURER	CATALOG #
EATON	MSEGR2

Grounding Clamps

CONDUIT	TAP CONDUCTOR RANGE	MANUFACTURER	CATALOG #
1/2" – 1"	#10 SOL – #2 STR	PENN-UNION	KP-1
			KP-1-DB
		BURNDY	C-11N
			C-11D
		NSI INDUSTRIES	G-1-S
			G-1
		ERICO	CWP1JSH
			CWP1JU
		HARGER	BGC4
		THOMAS & BETTS	J
JD			
1-1/4" – 2"	#10 SOL – #2 STR	PENN-UNION	KP-2
			KP-2-DB
		BURNDY	C-22
			C-22D
		NSI INDUSTRIES	G-2-S
			G-2
		ERICO	CWP2JSH
			CWP2JU
		HARGER	BGC41.25-2
		THOMAS & BETTS	J2BB
J2D			
2-1/2" – 4"	#10 SOL – #2 STR	PENN-UNION	KP-4
		BURNDY	C-4
		NSI INDUSTRIES	G-4-S
			G-4
			G-4-SBS
		HARGER	BGC42.5-4
4-1/2" – 6"	#10 SOL – #2 STR	PENN-UNION	KP-6
		BURNDY	C-8
		NSI INDUSTRIES	G-6-S
			G-6

Appendix B

These excerpts from the NEC are placed here for your convenience. For more detail information, please consult the NEC.

VI. Service Equipment - Disconnecting Means

230.70 General. Means shall be provided to disconnect all conductors in a building or other structure from the service-entrance conductors.

(A) Location. The service disconnecting means shall be installed in accordance with 230.70(A)(1), (A)(2), and (A)(3).

(1) Readily Accessible Location. The service disconnecting means shall be installed at a readily accessible location either outside of a building* or structure or inside nearest the point of entrance of the service conductors.

(2) Bathrooms. Service disconnecting means shall not be installed in bathrooms.

(3) Remote Control. Where a remote control device(s) is used to actuate the service disconnecting means, the service disconnecting means shall be located in accordance with 230.70(A)(1).

(B) Marking. Each service disconnect shall be permanently marked to identify it as a service disconnect.

(C) Suitable for Use. Each service disconnecting means shall be suitable for the prevailing conditions. Service equipment installed in hazardous (classified) locations shall comply with the requirements of Articles 500 through 517.

* LU requires an external disconnect.

230.71 Maximum Number of Disconnects

(A) General. The service disconnecting means for each service permitted by 230.2, or for each set of service-entrance conductors permitted by 230.40, Exception No. 1, 3, 4, or 5, shall consist of not more than six switches or sets of circuit breakers, or a combination of not more than six switches and sets of circuit breakers, mounted in a single enclosure, in a group of separate enclosures, or in or on a switchboard. There shall be not more than six sets of disconnects per service grouped in any one location.

Table 250.66 Grounding Electrode Conductor for Alternating-Current Systems

Size Of Largest Service-Entrance Conductor Or Equivalent Area For Parallel Conductors ^a (AWG/kcmil)		Size Of Grounding Electrode Conductor (AWG/kcmil)	
Copper	Aluminum or Copper-Clad Aluminum	Copper	Aluminum or Copper-Clad Aluminum ^b
2 or smaller	1/0 or smaller	8	6
1 or 1/0	2/0 or 3/0	6	4
2/0 or 3/0	4/0 or 250	4	2
Over 3/0 through 350	Over 250 through 350	2	1/0
Over 350 through 600	Over 500 through 900	1/0	3/0
Over 600 through 1100	Over 900 through 1750	2/0	4/0
Over 1100	Over 1750	3/0	250kcmil

Notes:

1. Where multiple sets of service-entrance conductors are used as permitted in 230.40, Exception No. 2, the equivalent size of the largest service-entrance conductor shall be determined by the largest sum of the areas of the corresponding conductors of each set.

2. Where there are no service-entrance conductors, the grounding electrode conductor size shall be determined by the equivalent size of the largest service-entrance conductor required for the load to be served.

a. This table also applies to the derived conductors of separately derived ac systems.

b. See installation restrictions in 250.64(A)

Table 310.15(B)(3)(a) Adjustment Factors for More Than Three Current-Carrying Conductors

Number of Conductors ¹	Percent of Values in Table 310.15(B)(16) Through Table 310.15(B)(19) as Adjusted for Ambient Temperature if Necessary
4–6	80
7–9	70
10–20	50
21–30	45
31–40	40

¹Number of conductors is the total number of conductors in the race- way or cable, including spare conductors. The count shall be adjusted in accordance with 310.15(B)(5) and (6). The count shall not include conductors that are connected to electrical components that cannot be simultaneously energized.

TABLE 310.15(B)(16) (formerly Table 310.16) Allowable Ampacities of Insulated Conductors Rated Up to and Including 2000 Volts, 60°C Through 90°C (140°F Through 194°F), Not More Than Three Current-Carrying Conductors in Raceway, Cable, or Earth (Directly Buried), Based on Ambient Temperature of 30°C (86°F)*

	60°C (140°F)	75°C (167°F)	90°C (194°F)	60°C (140°F)	75°C (167°F)	90°C (194°F)	Size AWG or kcmil
	Types TW, UF	Types RHW, THHW, THW, THWN, XHHW, USE, ZW	Types TBS, SA, SIS, FEP, FEPB, MI, RHH, RHW-2, THHN, THHW, THW-2, THWN-2, USE-2, XHH, XHHW, XHHW-2, ZW-2	Types TW, UF	Types RHW, THHW, THW, THWN, XHHW, USE	Types TBS, SA, SIS, THHN, THHW, THW-2, THWN-2, RHH, RHW-2, USE-2, XHH, XHHW, XHHW-2, ZW-2	
	COPPER			ALUMINUM OR COPPER-CLAD ALUMINUM			
18**	—	—	14	—	—	—	—
16**	—	—	18	—	—	—	—
14**	15	20	25	—	—	—	—
12**	20	25	30	15	20	25	12**
10**	30	35	40	25	30	35	10**
8	40	50	55	35	40	45	8
6	55	65	75	40	50	55	6
4	70	85	95	55	65	75	4
3	85	100	115	65	75	85	3
2	95	115	130	75	90	100	2
1	110	130	145	85	100	115	1
1/0	125	150	170	100	120	135	1/0
2/0	145	175	195	115	135	150	2/0
3/0	165	200	225	130	155	175	3/0
4/0	195	230	260	150	180	205	4/0
250	215	255	290	170	205	230	250
300	240	285	320	195	230	260	300
350	260	310	350	210	250	280	350
400	280	335	380	225	270	305	400
500	320	380	430	260	310	350	500
600	350	420	475	285	340	385	600
700	385	460	520	315	375	425	700
750	400	475	535	320	385	435	750
800	410	490	555	330	395	445	800
900	435	520	585	355	425	480	900
1000	455	545	615	375	445	500	1000
1250	495	590	665	405	485	545	1250
1500	525	625	705	435	520	585	1500
1750	545	650	735	455	545	615	1750
2000	555	665	750	470	560	630	2000

Temperature Rating of Conductor [See Table 310.104(A).]

*Refer to 310.15(B)(2) for the ampacity correction factors where the ambient temperature is other than 30°C (86°F). Refer to 310.15(B)(3)(a) for more than three current-carrying conductors.

**Refer to 240.4(D) for conductor overcurrent protection limitations.

THIS PAGE INTENTIONALLY LEFT BLANK

Most Common Reasons For Delays in Service Connection

- **CUSTOMER HAS NOT APPLIED FOR SERVICE**
- **THE SERVICE PATH WAS NOT CLEAR**
- **METER SOCKET WAS NOT GROUNDED**
- **NO GROUND ROD OR IMPROPER GROUND ROD**
- **METER SOCKET WAS EITHER TOO HIGH OR LOW**
- **METER SOCKET WAS NOT PROPERLY ATTACHED**
- **METER SOCKET WAS IMPROPERLY WIRED**
- **WEATHERHEAD WAS TOO LOW**
- **NO SERVICE ATTACHMENT POINT OR BRACKET**
- **SERVICE ATTACHMENT POINT WAS TOO LOW**
- **WRONG SIZE OR TYPE OF CONDUIT (WATER PIPE IS NOT ALLOWED)**
- **NO STRAPS ON THE CONDUIT**
- **TRENCH WAS TOO SHALLOW**
- **TRENCH PATH WAS NOT LINE OF SIGHT**
- **WRONG GROUND WIRE SIZE**
- **GROUND WIRE WAS NOT ATTACHED**
- **NO PROTECTIVE BUSHINGS ON THE CONDUITS**
- **CONDUIT WAS NOT PROPERLY SUPPORTED IN THE BOTTOM OF THE TRENCH**
- **LOCAL INSPECTION NOT OBTAINED (AS REQUIRED)**
- **MULTIPLE SOCKETS/SERVICES WERE NOT LABELED CORRECTLY**
- **CONSTRUCTION FEES NOT PAID**